

METALIKA
COMPONENTS FOR INDUSTRY KACIM



2023 | Catalog | Connection solutions gas industry

WEH[®] Gas Connectors

for pressure-tight connections in seconds
for technical gas applications



WEH[®] - We Engineer Hightech

Slovenija
 (+386) 041 694 339
 info@metalika-kacin.com
 Hrvatska
 (+385) 051 213 060
 hrvatska@metalika-kacin.com
 Srbija
 (+381) 011 25 21 756
 srbija@metalika-kacin.com

» Table of contents

1 	Products for the gas industry	6
1.1	Introduction	6
1.2	Overview	7
2 	WEH® Connectors for filling	8
2.1	TW54	8
2.2	TW57	12
2.3	TW101	16
2.4	TW102	20
2.5	TW52	24
2.6	TW152	28
2.7	TW42	32
2.8	TW53	34
2.9	TW59	36
2.10	TW67	38
2.11	TW640	44
2.12	TW670	48
3 	WEH® Connectors for testing	52
3.1	TW17	52
3.2	TW117	56

© All rights reserved, WEH GmbH Verbindungstechnik.
 Any unauthorized copying, distribution or other use of the copyrighted content is strictly forbidden without the written consent of WEH GmbH Verbindungstechnik.
 Upon transmission of a newer version of this document, all previous versions are no longer valid. In principle, the latest version of the document is valid. This can be found at www.weh.com.
 Our General Terms and Conditions and the Agreement on Protection of Know-How and Quality Assurance (www.weh.com) shall apply to deliveries and other services, unless expressly agreed otherwise.
 We do not accept any General Terms and Conditions of the purchaser.

WEH® is a registered trademark of WEH GmbH Verbindungstechnik.

» Table of contents

4 Accessories	58
4.1 TD1	58
4.2 TK350-TN350	60
4.3 TVR2	64
4.4 TSF4	66
4.5 THP40	68
5 Further Information	72
5.1 Technical appendix	72
5.2 Brochure data	75

» Introduction

IMPRESSIONS



WEH® TW57 for filling of gas cylinders with male thread



WEH® TW42 for medical oxygen applications with Pin-Index connection

» Introduction

WEH® – INNOVATIVE CONNECTORS FOR GAS CYLINDER FILLING

Since 1983 WEH has been developing the world's most technically advanced quick connector solutions for the gas filling industry - and in the process improving productivity and operator health and safety immensely. New solutions had to be found satisfying more and more demanding requirements for safety and leak tightness of products used for filling gaseous media at high-pressure. Today a complete product range is available for a large variety of gases and gas mixtures, e.g. inert gases, oxygen, nitrogen, propane, acetylene, CO₂, medical gases etc.

A suitable WEH® Connector is available for valve configurations having female or male threads (with or without a residual pressure valve) or PIN-Index connections.

The WEH® Connector connects directly to the cylinder valve thread using the corresponding national standard, e.g. DIN, CGA, BS, NF and CEN and provides a pressure-tight connection in seconds.

The quick connectors are made of stainless steel and brass and the seals are specially selected to suit the corresponding media.

Unique WEH® Jaw locking mechanism

All quick connectors have the unique jaw locking mechanism developed by WEH.

The jaw locking mechanism is superior to hand tightening systems in that it tolerates dirt and reduces wear on the cylinder valve.

The quick connector is placed onto or into the cylinder valve, the operating loop or lever is moved down and the pressure-tight connection is made.



Benefits

- Connection in seconds directly to the cylinder valve thread
- Integrated safety peg prevents disconnection under pressure
- Unique WEH® Jaw locking mechanism
- Compact design

High safety standard due to enhanced test procedures

Quick connectors for gas filling applications are designed to meet demanding technical, commercial and health requirements from customers. Therefore all connectors are subjected to 100,000 cycles of extensive pressure and durability tests in our own testing laboratory.

Connectors for filling oxygen are oxygen cleaned and are subjected to an additional type approval for suitability against adiabatic compression.

Extensive range of accessories

All WEH® Connectors are adapted to specific customer requirements. Cylinders with and without safety caps can be filled. A large variety of actuations is available - loops, wire ropes etc. - for different cylinder sizes.

A swivel joint enabling the axial alignment of the WEH® Connector to the cylinder valve thread when connecting is available for ease of operation. Check valves and filters complete the product range.



TW54 with special loop for female thread



TW54 with swivel joint for female thread



TW57 with wire rope and locking device for male thread



TW17 with lever handle for female thread

» Overview

OVERVIEW WEH® CONNECTORS

Overview filling connectors										
Type	Page	Max. operating pressure PS	Norms / standards				Connection to			Version RPV / Non-RPV
			DIN	CGA	BS	NF	Female thread	Male thread	Pin-Index	
TW54	8	250 bar 375 bar	✓	✓	✓	✓	✓			✓
TW57	12	250 bar 375 bar	✓	✓	✓	✓		✓		✓
TW101	16	250 bar	✓	✓	✓	✓	✓			✓*
TW102	20	250 bar	✓	✓	✓	✓		✓		✓*
TW52	24	250 bar 150 bar	✓	✓	✓	✓		✓		✓
TW152	28	250 bar	✓	✓	✓	✓		✓		✓
TW42	32	250 bar		✓					✓	✓
TW53	34	30 bar	✓							
TW59	36	30 bar	✓					✓		
TW67	38	250 bar 375 bar	✓	✓	✓	✓		✓		✓
TW640	44	375 bar	✓	✓	✓	✓	✓			
TW670	48	375 bar	✓	✓	✓	✓		✓		
Overview testing connectors										
Type	Page	Max. operating pressure PS	Norms / standards				Connection to			Version RPV / non-RPV
			DIN	CGA	BS	NF	Female thread	Male thread	Pin-Index	
TW17	52	350 bar	✓				✓			
TW117	56	450 bar	✓				✓			

* Only versions for residual pressure valves available

ORDERING

Normally we need the following information when ordering:

1. Part No. / connection sizes
2. National standard
3. Pressure range
4. Medium / requested leak rate
5. Description of application
6. Temperature range
7. CAD drawing of customer test piece
8. Test piece

For reasons of precaution, we'd like to point out that

- a) regarding the delivery of each article acc. to the respective order confirmation - in particular concerning ECE / EC79 articles - WEH does not confirm the fulfilment of additional requirements of the concerned end customer,
 - b) WEH is not subject to any external reporting obligation with regard to external change management (see page 74) and
 - c) WEH does not confirm the replacement of the product in the form of a regular series delivery.
- Exclusions acc. to a) - c) can be agreed with the conclusion of a customer-specific project with corresponding special conditions.

» WEH® Connector TW54

DESCRIPTION

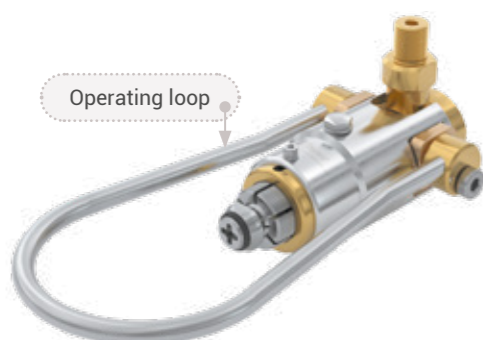

Features

- For gas cylinders with female thread
- Version for cylinder valves with or without a residual pressure valve
- Connection in seconds
- No hand tightening required
- Easy to connect
- Right-hand and left-hand operation
- Suitable for pallet filling
- WEH® Jaw locking mechanism
- Compact design
- High-grade materials

The WEH® TW54 Quick connector for gas cylinder valves with female thread provides a pressure-tight connection in seconds. The split collet design system locks securely into the cylinder valve thread and seals tightly.

Safety features

A fully developed design with simple actuation controlling the functioning of the gas connector. The quick connector cannot be disconnected under pressure because a special safety peg protrudes and locks the connector against removal.

The TW54 quick connector has a red marking at the front part of the connector (see opposite picture) which shows when a proper connection has been made.

The TW54 for oxygen has venting bores (see opposite picture) in the front sleeve for lateral venting of gas in case of accidental gas leakage, thus preventing pressure built-up in the connector.



TW54 with RPV pin and venting bores

The TW54 is suitable for gas cylinders with a nominal operating pressure of 200 bar resp. 300 bar.

This quick connector is available for gas cylinder valves acc. to DIN, BS, NF, CGA etc. Connectors for oxygen applications are oxygen cleaned and free of oil and grease.

Application

Quick connector for filling of gas cylinders with female thread (with or without a residual pressure valve).

TECHNICAL DATA

Characteristics	Basic version
Max. allowable operating pressure PS	250 bar resp. 375 bar
Temperature range	+5 °C up to +80 °C +5 °C up to +60 °C (O ₂)
Connection A	Female thread connection acc. to the corresponding national standard e.g. DIN, CGA, BS, NF etc.
Medium	Oxygen, nitrogen, CO ₂ , air, inert gases, medical gases
Actuation	Manual actuation via operating loop (loop depending on type of gas cylinder)
Material	Corrosion resistant stainless steel, brass
Sealing material	Acc. to gas type
Design	With or without RPV pin
Conformity / Tests / Approvals	Type approval for suitability against adiabatic compression available

Example of use:



Other designs on request

» WEH® Connector TW54

ORDERING | WEH® TW54 Quick connector for non-residual pressure valves

approx. dimensions (mm)

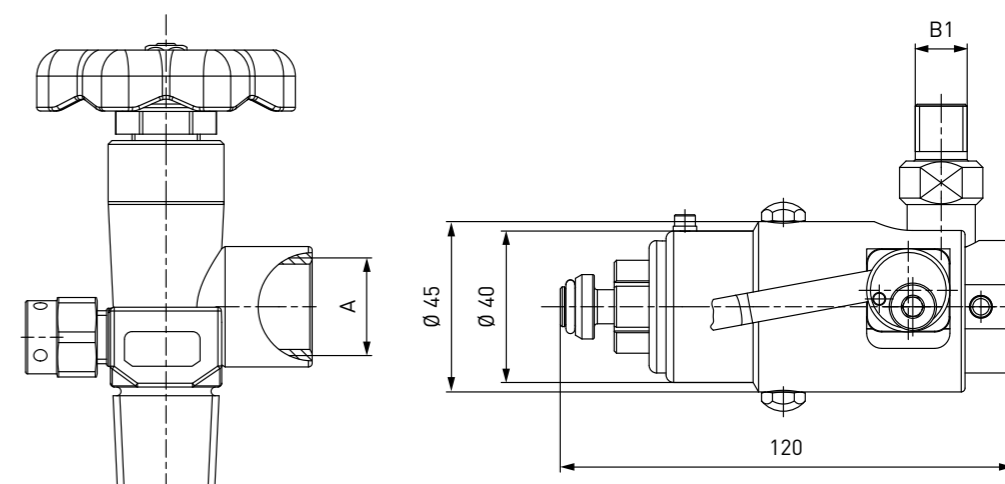

Part No.	Description	Pressure (PS)	A	B1 (male thread)
On request	TW54	250 bar	On request	On request
On request	TW54	375 bar	On request	On request

ORDERING | WEH® TW54 Quick connector for residual pressure valves

approx. dimensions (mm)

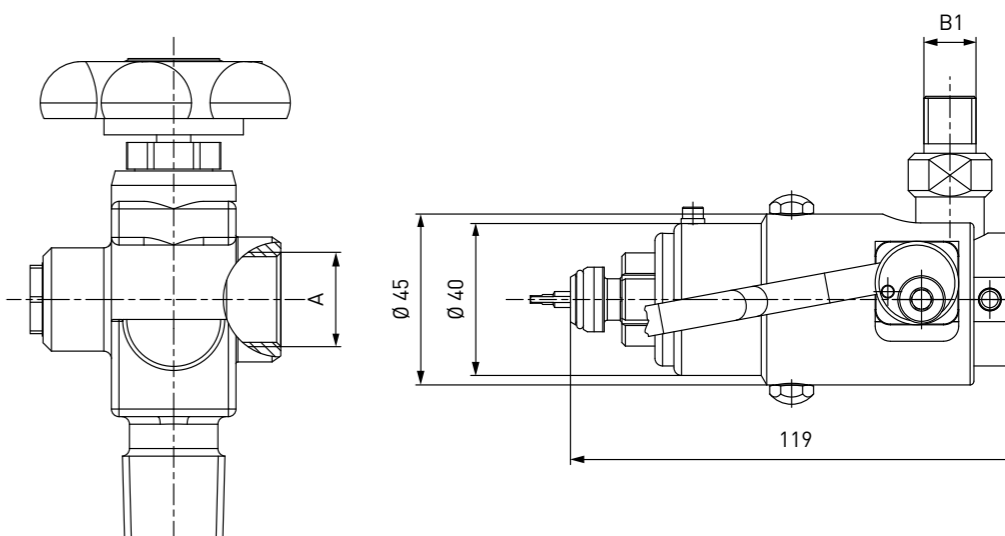

Part No.	Description	Pressure (PS)	A	B1 (male thread)
On request	TW54	250 bar	On request	On request
On request	TW54	375 bar	On request	On request

Other connection sizes and types on request.

Required information for ordering see page 7.

» WEH® Connector TW54

ACCESSORIES

The following accessories are available for the WEH® TW54 Quick connector:

Swivel joint WEH® TD1 (see page 58)

Quick release coupling WEH® TK350-TN350 (see page 60)

Pressure hose WEH® THP40 (see page 68)

Actuations

For WEH® TW54 various actuations, e.g. loops, wire ropes, manual lever handles etc. are available in different sizes and forms. Please contact us!

Locking devices

Additional locking devices are also available for WEH® TW54. Please contact us!

Connection for pressure gauges

Quick connector incl. pressure gauge connection and venting valve for pressure monitoring of filled gas cylinders.



Part No.	Description
On request	TW54 incl. pressure gauge connection and venting valve

» WEH® Connector TW54

Adaptors

Adaptors for connecting the quick connector to the filling hose are available on request.

Monel® construction

All pressurized parts are also available in Monel®. Please contact us!

SPARE PARTS

Various parts are available as spares for the WEH® TW54 Quick connector.

Part No.	Description
On request	Spare seals

» WEH® Connector TW57

DESCRIPTION

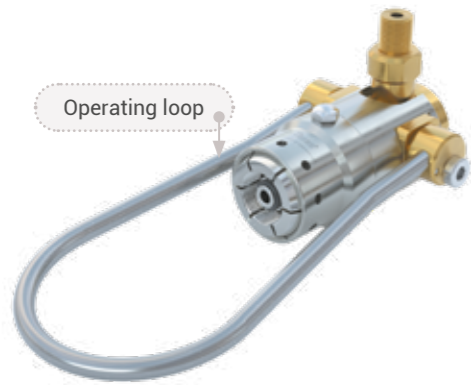

Features

- For gas cylinders with male thread
- Version for cylinder valves with or without a residual pressure valve
- Connection in seconds
- No hand tightening required
- Easy to connect
- Right-hand and left-hand operation
- Suitable for pallet filling
- WEH® Jaw locking mechanism
- Compact design
- High-grade materials

The WEH® TW57 Quick connector for gas cylinder valves with male thread provides a pressure-tight connection in seconds. The split collet design system locks securely onto the cylinder valve thread and seals tightly.

Safety features

A fully developed design with simple actuation controlling the functioning of the gas connector. The quick connector cannot be disconnected under pressure because a special safety peg protrudes and locks the connector against removal. The TW57 for oxygen has venting bores (see opposite picture) in the front sleeve for lateral venting of gas in case of accidental gas leakage, thus preventing pressure built-up in the connector.



TW57 with RPV pin and venting bores

The TW57 is suitable for gas cylinders with a nominal operating pressure of 200 bar resp. 300 bar.

This quick connector is available for gas cylinder valves acc. to DIN, BS, NF, CGA etc. Connectors for oxygen applications are oxygen cleaned and free of oil and grease.

Application

Quick connector for filling of gas cylinders with male thread (with or without a residual pressure valve).

TECHNICAL DATA

Characteristics	Basic version
Max. allowable operating pressure PS	250 bar resp. 375 bar
Temperature range	+5 °C up to +80 °C +5 °C up to +60 °C (O ₂)
Connection A	Male thread connection acc. to the corresponding national standard e.g. DIN, CEN, CGA, BS, NF etc.
Medium	Oxygen, nitrogen, CO ₂ , air, inert gases, medical gases
Actuation	Manual actuation via operating loop (loop depending on type of gas cylinder)
Material	Corrosion resistant stainless steel, brass
Sealing material	Acc. to gas type
Design	With or without RPV pin
Conformity / Tests / Approvals	Type approval for suitability against adiabatic compression available

Other designs on request

Example of use:



» WEH® Connector TW57

ORDERING | WEH® TW57 Quick connector for non-residual pressure valves

approx. dimensions (mm)

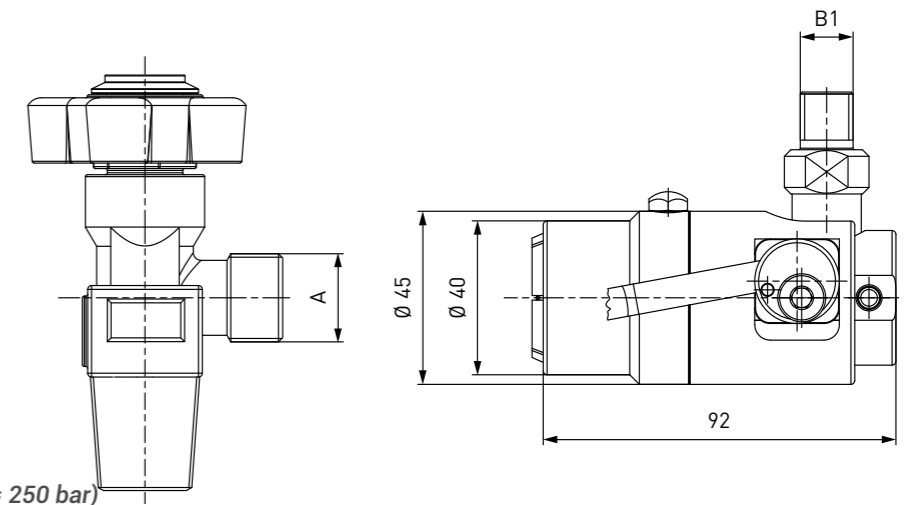

Quick connector TW57 (PS = 250 bar)

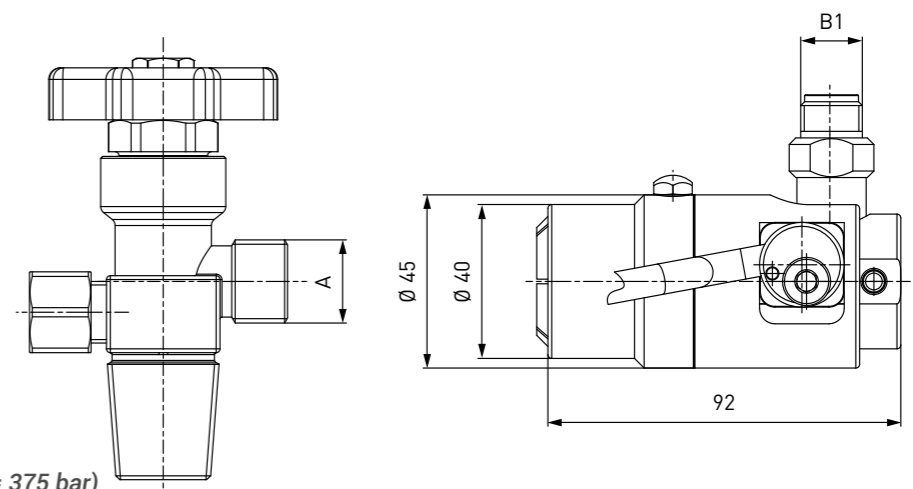

Quick connector TW57 (PS = 375 bar)

Part No.	Description	Pressure (PS)	A	B1 (male thread)
On request	TW57	250 bar	On request	On request
On request	TW57	375 bar	On request	On request



» WEH® Connector TW57

ORDERING | WEH® TW57 Quick connector for residual pressure valves

approx. dimensions (mm)

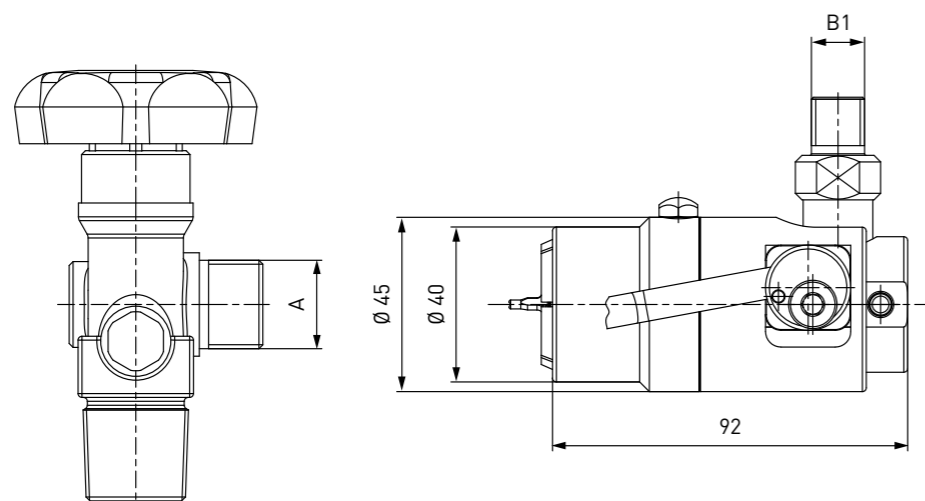

Quick connector TW57 RPV (PS = 250 bar)

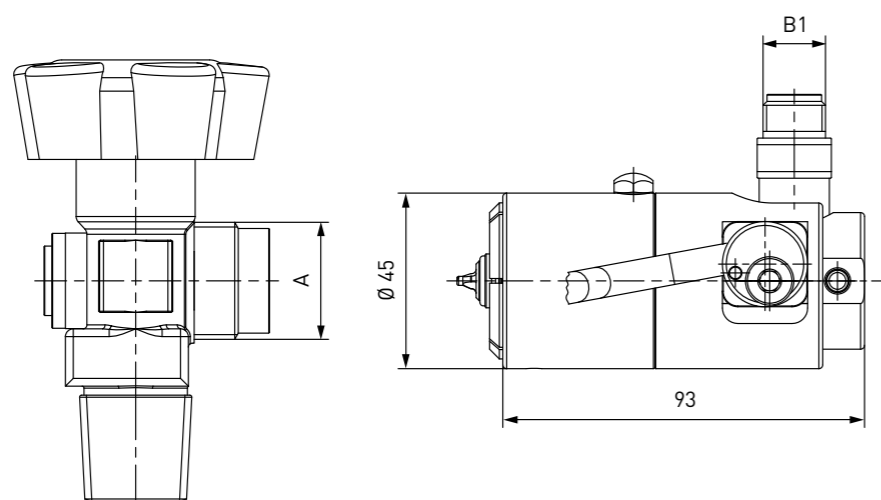

Quick connector TW57 RPV (PS = 375 bar)



Part No.	Description	Pressure (PS)	A	B1 (male thread)
On request	TW57	250 bar	On request	On request
On request	TW57	375 bar	On request	On request

Other connection sizes and types on request.

Required information for ordering see page 7.

» WEH® Connector TW57

ACCESSORIES

The following accessories are available for the WEH® TW57 Quick connector:

Swivel joint WEH® TD1 (see page 58)

Quick release coupling WEH® TK350-TN350 (see page 60)

Pressure hose WEH® THP40 (see page 68)

Actuations

For WEH® TW57 various actuations, e.g. loops, wire ropes, manual lever handles etc. are available in different sizes and forms. Please contact us!

Locking devices

Additional locking devices are also available for WEH® TW57. Please contact us!

Connection for pressure gauges

Quick connector incl. pressure gauge connection and venting valve for pressure monitoring of filled gas cylinders.



Part No.	Description
On request	TW57 incl. pressure gauge connection and venting valve

Adaptors

Adaptors for connecting the quick connector to the filling hose are available on request.

Monel® construction

All pressurized parts are also available in Monel®. Please contact us!

SPARE PARTS

Various parts are available as spares for the WEH® TW57 Quick connector.

Part No.	Description
On request	Spare seals

» WEH® Connector TW101

DESCRIPTION

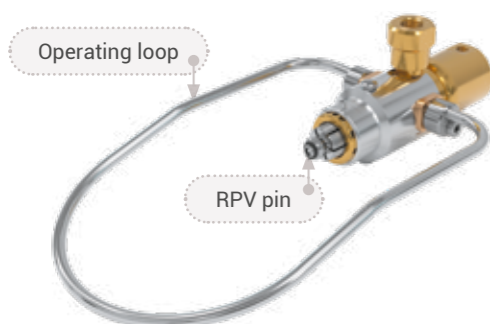

Features

- For gas cylinders with female thread and pressure regulator
- Connection in seconds
- No hand tightening required
- Easy to connect
- WEH® Jaw locking mechanism
- Compact design
- High-grade materials

The WEH® TW101 Quick connector for gas cylinder valves with female thread and pressure regulator provides a pressure-tight connection in seconds. The split collet design system locks securely into the cylinder valve thread and seals tightly. The residual pressure valve on the gas cylinder valve opens pneumatically. On request the opening can also be effected manually via hand lever.

Safety features

A fully developed design with simple actuation controlling the functioning of the gas connector. The quick connector cannot be disconnected under pressure because a special safety peg protrudes and locks the connector against removal.

The TW101 quick connector has a red marking at the front part of the connector (see opposite picture) which shows when a proper connection has been made.

Type TW101 for oxygen has venting bores (see opposite picture) in the front sleeve for lateral venting of gas in case of accidental gas leakage, thus preventing pressure built-up in the connector.



Red marking and venting bores

This quick connector is available for gas cylinder valves acc. to DIN, BS, NF, CGA etc. Connectors for oxygen applications are oxygen cleaned and free of oil and grease.

Application

Quick connector for filling and evacuating of gas cylinders with female thread and pressure regulator.

TECHNICAL DATA

Characteristics	Basic version
Max. allowable operating pressure PS	250 bar
Pilot pressure	Max. 6 - 8 bar (for opening residual pressure valve)
Temperature range	+5 °C up to +60 °C (O ₂)
Connection A	Female thread connection acc. to the corresponding national standard e.g. DIN, CGA, BS, NF etc.
Medium	Medical oxygen
Actuation	Manual actuation via operating loop (loop depending on type of gas cylinder) Opening / closing of the RPV pin in the valve: via pneumatic pilot pressure line
Material	Corrosion resistant stainless steel, brass, Monel®
Sealing material	EPDM
Design	Incl. adaptor and RPV pin
Conformity / Tests / Approvals	Type approval for suitability against adiabatic compression available

Other designs on request

Example of use:



» WEH® Connector TW101

ORDERING | WEH® TW101 Quick connector

approx. dimensions (mm)

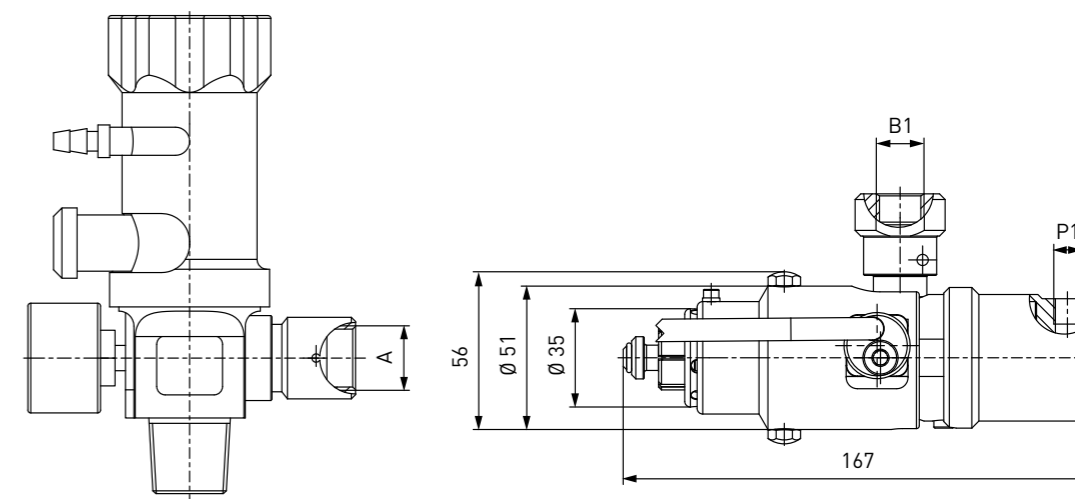

Part No.	Description	A	B1	P1 (female thread)
On request	TW101	On request	On request	G1/8"

Other connection sizes and types on request.

Required information for ordering see page 7.

» WEH® Connector TW101

ACCESSORIES

The following accessories are available for the WEH® TW101 Quick connector:

Swivel joint WEH® TD1 (see page 58)

Pressure hose WEH® THP40 (see page 68)

Actuations

For WEH® TW101 various actuations, e.g. loops, wire ropes, manual lever handles etc. are available in different sizes and forms. Please contact us!

Adaptors

Adaptors for connecting the quick connector to the filling hose are available on request.

Monel® construction

All pressurized parts are also available in Monel®. Please contact us!

» WEH® Connector TW101

SPARE PARTS

Various parts are available as spares for the WEH® TW101 Quick connector.

Part No.	Description
On request	Spare seals

» WEH® Connector TW102

DESCRIPTION

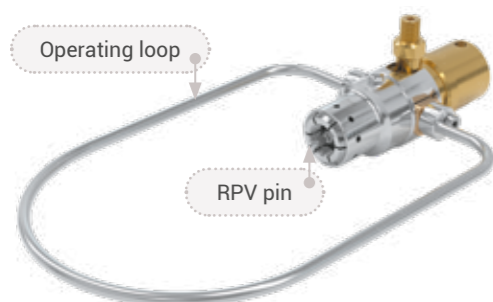

Features

- For gas cylinders with male thread and pressure regulator
- Connection in seconds
- No hand tightening required
- Easy to connect
- WEH® Jaw locking mechanism
- Compact design
- High-grade materials

The WEH® TW102 Quick connector for gas cylinder valves with male thread and pressure regulator provides a pressure-tight connection in seconds. The split collet design system locks securely onto the cylinder valve thread and seals tightly. The residual pressure valve on the gas cylinder valve opens pneumatically. On request the opening can also be effected manually via hand lever.

Safety features

A fully developed design with simple actuation controlling the functioning of the gas connector. The quick connector cannot be disconnected under pressure because a special safety peg protrudes and locks the connector against removal.

Type TW102 for oxygen has venting bores (see opposite picture) in the front sleeve for lateral venting of gas in case of accidental gas leakage, thus preventing pressure built-up in the connector.



Venting bores

This quick connector is available for gas cylinder valves acc. to DIN, BS, NF, CGA etc. Connectors for oxygen applications are oxygen cleaned and free of oil and grease.

Application

Quick connector for filling and evacuating of gas cylinders with male thread and pressure regulator.

TECHNICAL DATA

Characteristics	Basic version
Max. allowable operating pressure PS	250 bar
Pilot pressure	Max. 6 - 8 bar (for opening residual pressure valve)
Temperature range	+5 °C up to +60 °C (O ₂)
Connection A	Male thread connection acc. to the corresponding national standard e.g. DIN, CGA, BS, NF etc.
Medium	Medical oxygen
Actuation	Manual actuation via operating loop (loop depending on type of gas cylinder) Opening / closing of the RPV pin in the valve: via pneumatic pilot pressure line
Material	Corrosion resistant stainless steel, brass, Monel®
Sealing material	EPDM
Design	Incl. adaptor and RPV pin
Conformity / Tests / Approvals	Type approval for suitability against adiabatic compression available

Other designs on request

Example of use:



» WEH® Connector TW102

ORDERING | WEH® TW102 Quick connector

approx. dimensions (mm)

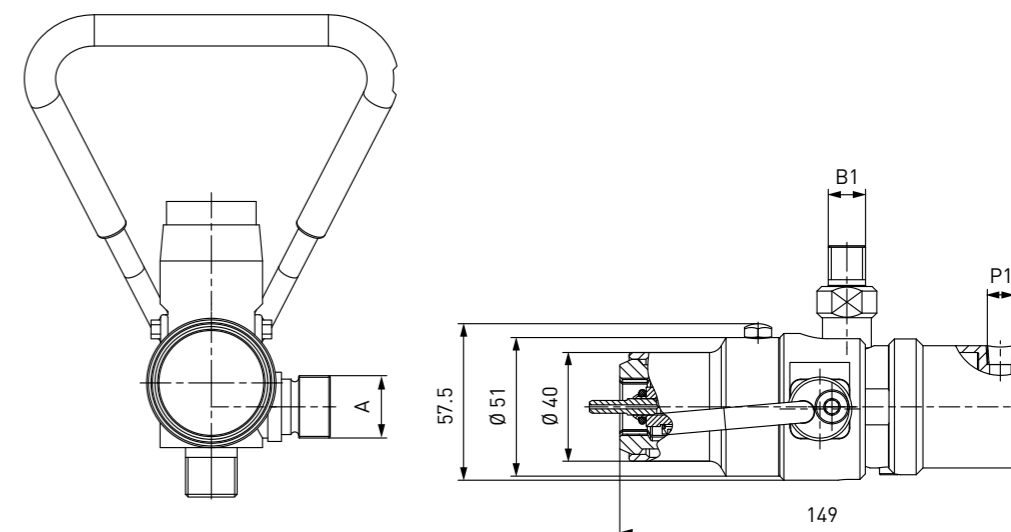

Part No.	Description	A	B1	P1 (female thread)
On request	TW102	On request	On request	G1/8"

Other connection sizes and types on request.

Required information for ordering see page 7.

» WEH® Connector TW102

ACCESSORIES

The following accessories are available for the WEH® TW102 Quick connector:

Swivel joint WEH® TD1 (see page 58)

Pressure hose WEH® THP40 (see page 68)

Actuations

For WEH® TW102 various actuations, e.g. loops, wire ropes, manual lever handles etc. are available in different sizes and forms. Please contact us!

Adaptors

Adaptors for connecting the quick connector to the filling hose are available on request.

Monel® construction

All pressurized parts are also available in Monel®. Please contact us!

» WEH® Connector TW102

SPARE PARTS

Various parts are available as spares for the WEH® TW102 Quick connector.

Part No.	Description
On request	Spare seals

» WEH® Connector TW52

DESCRIPTION

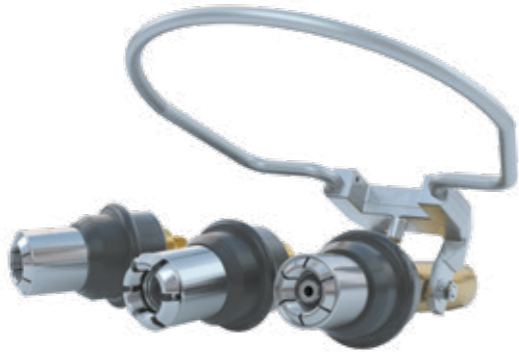

Features

- Suitable for filling of CO₂ or refrigerants
- Version for cylinder valves with or without a residual pressure valve
- Connection in seconds
- No hand tightening required
- High safety due to pressure-assisted piston
- Environmentally friendly - a vent pipe recirculates the vented gas (in conjunction with TVCO₂)
- WEH® Jaw locking mechanism
- High-grade materials

The WEH® TW52 Quick connector is specially developed for filling gas cylinders with refrigerants or gaseous and liquid CO₂. Connection to the cylinder is made within seconds without tedious screwing and unscrewing, thus preventing RSI resulting in the inflammation of tendons and abrasion of joints.

The TW52 is also suitable for filling one litre cylinders, e.g. for soda drinks.

The WEH® TW52 is equipped with a front seal of EPDM resp. polyurethane. Other sealing materials on request. It is the customer's responsibility to clarify the media compatibility.

The TW52 is optionally available with the WEH® TVCO₂ shut-off valve (see accessories).

This quick connector is available for gas cylinder valves acc. to DIN, BS, NF, CGA etc.

Application

Quick connector for filling and evacuating (except version with TVCO₂ shut-off valve) of gas cylinders with male thread (with or without a residual pressure valve) with CO₂ or refrigerants.

TECHNICAL DATA

Characteristic	Basic version
Nominal bore (DN)	5 mm
Max. allowable operating pressure PS	250 bar 150 bar (TW52 with TVCO ₂ shut-off valve)
Temperature range	-40 °C up to +40 °C (CO ₂)
Connection A	Male thread connection acc. to the corresponding national standard e.g. DIN, CGA, BS, NF etc.
Actuation	Manual actuation via grip sleeve
Material	Corrosion resistant stainless steel and brass
Sealing material	Front seal of EPDM resp. polyurethane (C1-16560, C1-17069)
Design	With or without RPV pin

Other designs on request

Example of use:



TW52 with TVCO₂ shut-off valve

» WEH® Connector TW52

ORDERING | WEH® TW52 Quick connector for non-residual pressure valves

approx. dimensions (mm)

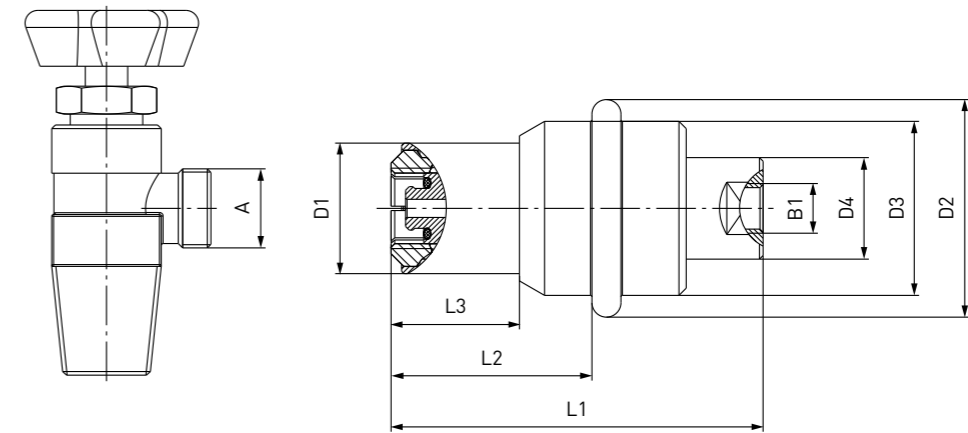

Part No.	Description	A (male thread)	B1 (female thread)	D1	D2	D3	D4	L1	L2	L3
C1-16560-X01	TW52	G1/2"	G1/4"	38	60	48	28	103	55.5	35.5
C1-16564-X01	TW52	W21.8x1/14**	G1/4"	36	60	48	28	103	55.5	35.5

* acc. to DIN 477

ORDERING | WEH® TW52 Quick connector for non-residual pressure valves (suitable for TVCO₂ shut-off valve)

approx. dimensions (mm)

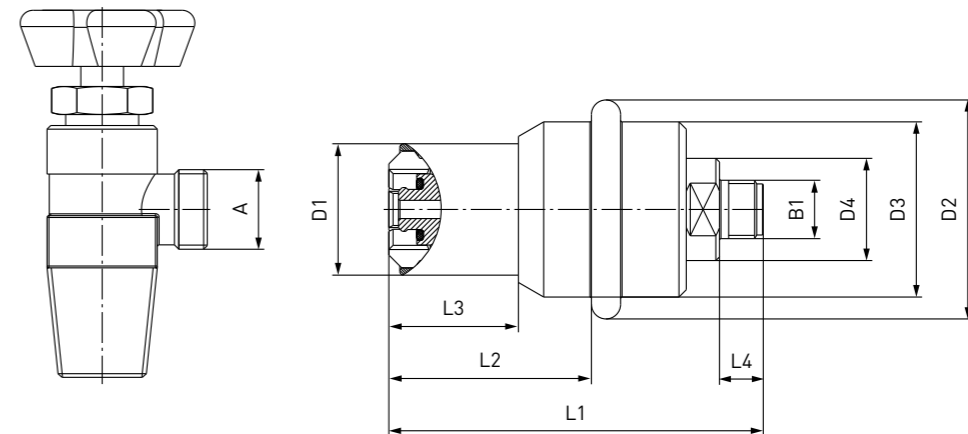

Part No.	Description	A (male thread)	B1 (male thread)	D1	D2	D3	D4	L1	L2	L3	L4
C1-16563	TW52	W21.8x1/14**	M16x1.5	36	60	48	28	103	55.5	35.5	12

* acc. to DIN 477

» WEH® Connector TW52

ORDERING | WEH® TW52 Quick connector for residual pressure valves (incl. shut-off valve)

approx. dimensions (mm)

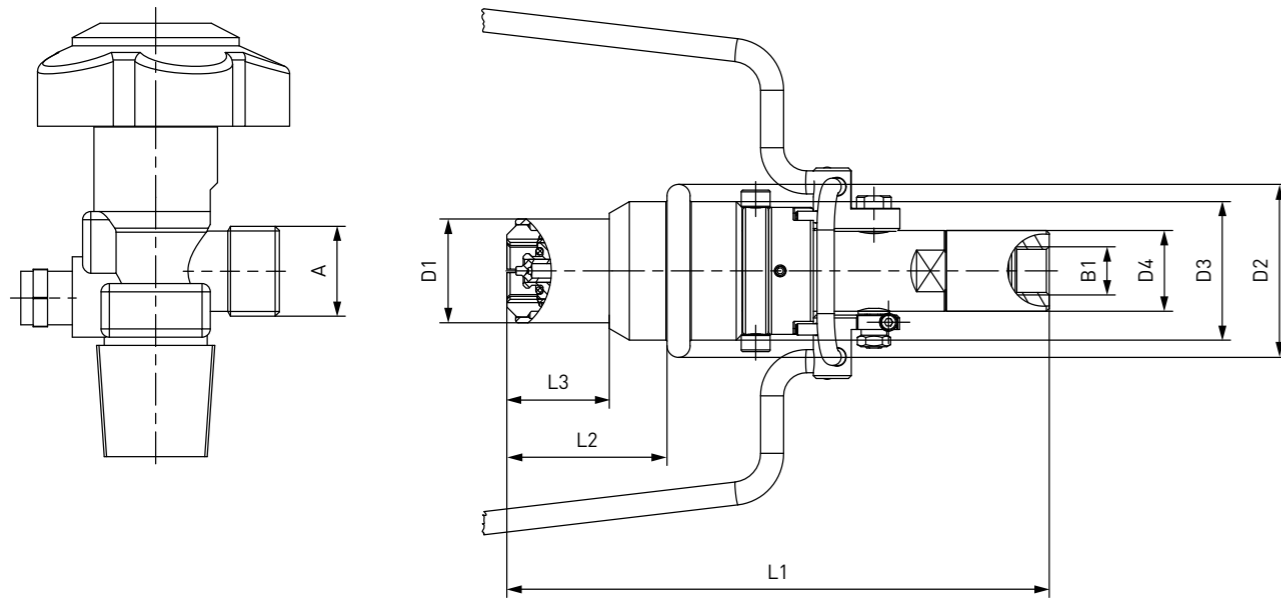

Part No.	Description	A (male thread)	B1 (female thread)	D1	D2	D3	D4	L1	L2	L3
C1-68486	TW52	W21.8x1/14**	G3/8"	36	60	48	28	188	55.5	35.5

* acc. to DIN 477

Other connector sizes and versions on request.

Required information for ordering see page 7.

ACCESSORIES

The following accessories are available for the WEH® TW52 Quick connector

Pressure hose WEH® THP40 (see page 68)

» WEH® Connector TW52

WEH® TVCO₂ Shut-off valve

The WEH® TVCO₂ Shut-off valve enables to start or finish filling. Simply connect the TVCO₂ to the inlet 'B1' of the TW52 quick connector. The residual gas can be vented completely to the system via a recirculation hose. This prevents CO₂ from escaping into the atmosphere.

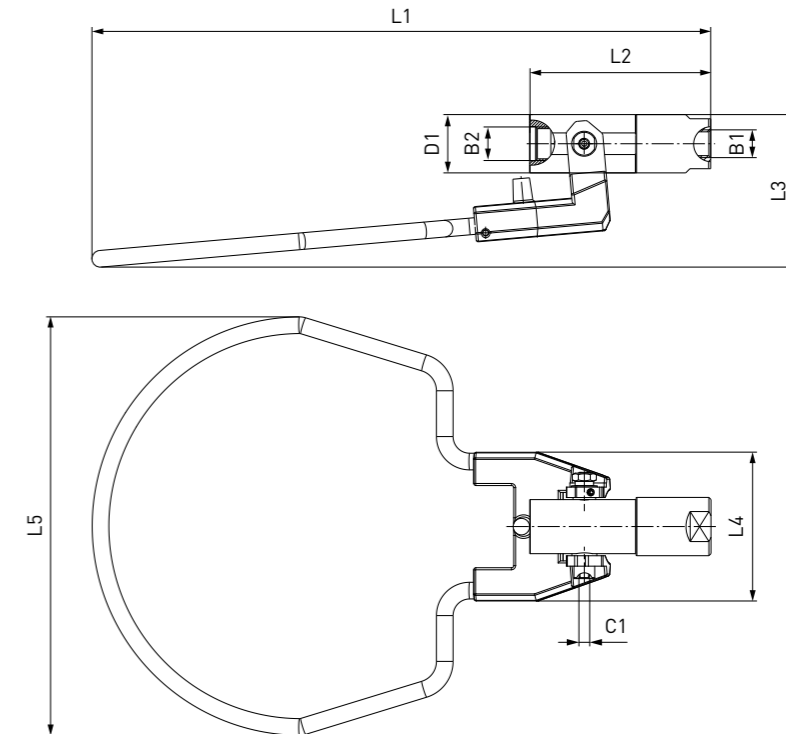

Part No.	Description	B1 (female thread)	B2 (female thread)	C1	D1	L1	L2	L3	L4	L5
C1-34605	TVCO ₂	G1/4"	M16x1.5	M5	28	297	87	73	71.5	201

Other connector sizes and versions on request.

SPARE PARTS

Various parts are available as spares for the WEH® TW52 Quick connector.

Part No.	Description
On request	Front seal

When ordering the front seal, please indicate the part no. engraved on the connector.

» WEH® Connector TW152

DESCRIPTION



Features

- For oxygen cylinders with male thread (with or without a residual pressure valve) and pressure regulator
- Connection in seconds
- No hand tightening required
- Automatic locking of the sliding sleeve under pressure prevents disconnection at pressures exceeding 5 bar
- Inline or 90° version available
- WEH® Jaw locking mechanism
- High-grade materials

The WEH® TW152 Quick connector is designed to achieve easier and more efficient filling of oxygen cylinders because it can be connected directly to the standard thread of the cylinder valve.

The function is quite simple: pull back the sliding sleeve and place the filling connector onto the male thread of the cylinder valve. The split collet design system locks securely onto the cylinder valve thread and seals tightly.

The connector has an internal locking mechanism preventing disconnection under pressure. WEH® TW152 can be connected to cylinder valves with or without a residual pressure valve and valves with integrated pressure regulators. Due to its compact design, it is also suitable for use in confined spaces.

This quick connector is available for gas cylinder valves acc. to DIN, BS, NF, CGA etc. Connectors for oxygen applications are oxygen cleaned and free of oil and grease.



TW152 with RPV pin

Application

Quick connector for filling of oxygen cylinders with male thread (with or without a residual pressure valve) and pressure regulator.

TECHNICAL DATA

Characteristics	Basic version
Nominal bore (DN)	5 mm
Max. allowable operating pressure PS	250 bar
Temperature range	+5 °C up to +60 °C (O ₂)
Connection A	Male thread connection acc. to the corresponding national standard e.g. DIN, CGA, BS, NF etc.
Medium	Medical oxygen
Actuation	Manual actuation via sliding sleeve
Material	Corrosion resistant stainless steel, brass, Monel®
Sealing material	EPDM
Design	With or without RPV pin
Conformity / Tests / Approvals	Type approval for suitability against adiabatic compression available

Other designs on request

Example of use:



» WEH® Connector TW152

ORDERING | WEH® TW152 Quick connector with inline media inlet

approx. dimensions (mm)

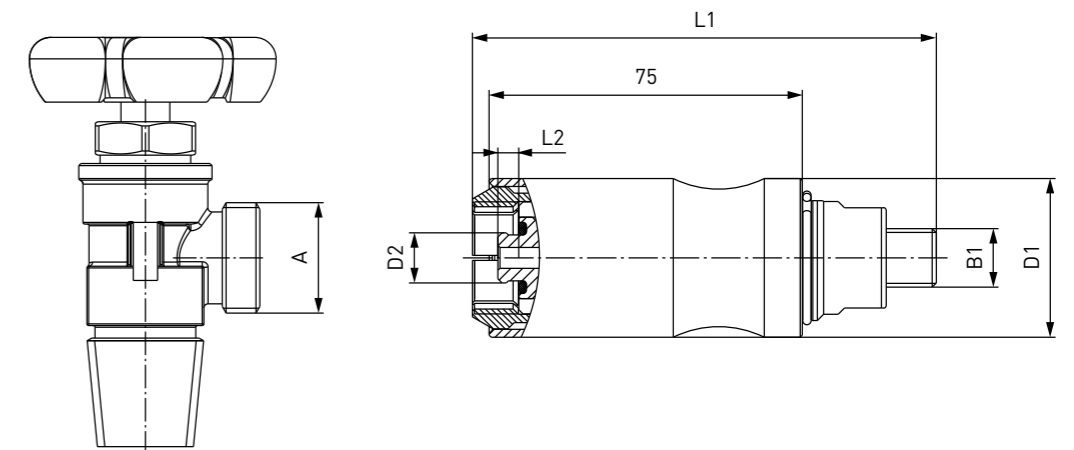

Part No.	Description	A (male thread)	B1 (male thread)	D1	D2	L1	L2
C1-62956-X01	TW152	W21.8x1/14" DIN 477 part 1	NPT 1/4"	38	12	111	5
C1-47060-X01	TW152	0.903-14 NGO-RH CGA 540	NPT 1/4"	38	-	111	-
C1-55583-X01*	TW152	0.903-14 NGO-RH CGA 540	NPT 1/4"	38	-	122	-

* with RPV pin

» WEH® Connector TW152

ORDERING | WEH® TW152 Quick connector with 90° media inlet

approx. dimensions (mm)

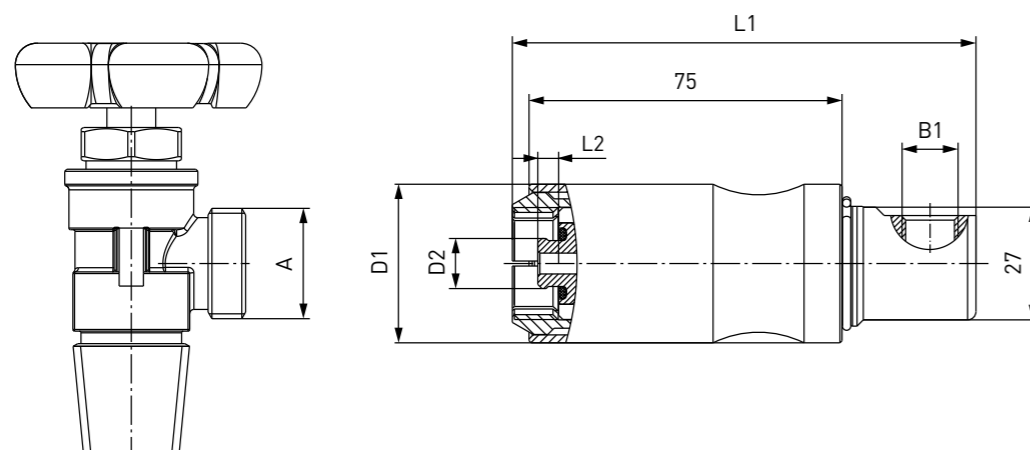

Part No.	Description	A (male thread)	B1 (female thread)	D1	D2	L1	L2
C1-62957-X01	TW152	W21.8x1/14" DIN 477 part 1	NPT 1/4"	38	12	111	5
C1-49930-X01	TW152	0.903-14 NGO-RH CGA 540	NPT 1/4"	38	-	111	-
C1-55579-X01*	TW152	0.903-14 NGO-RH CGA 540	NPT 1/4"	38	-	122	-

* with RPV pin

Other connection sizes and types on request.

Required information for ordering see page 7.

» WEH® Connector TW152

ACCESSORIES

The following accessories are available for the WEH® TW152 Quick connector:

Swivel joint WEH® TD1 (see page 58)

Pressure hose WEH® THP40 (see page 68)

Adaptors

Adaptors for connecting the quick connector to the filling hose are available on request.

Monel® construction

All pressurized parts are also available in Monel®. Please contact us!

SPARE PARTS

Various parts are available as spares for the WEH® TW152 Quick connector.

Part No.	Description
E50-109S614	O-ring (for C1-62956-X01, C1-62957-X01)
E50-069S614	O-ring (for C1-55583-X01, C1-55579-X01)
E50-46786-S611	O-ring (for C1-47060-X01, C1-49930-X01)

» WEH® Connector TW42

DESCRIPTION

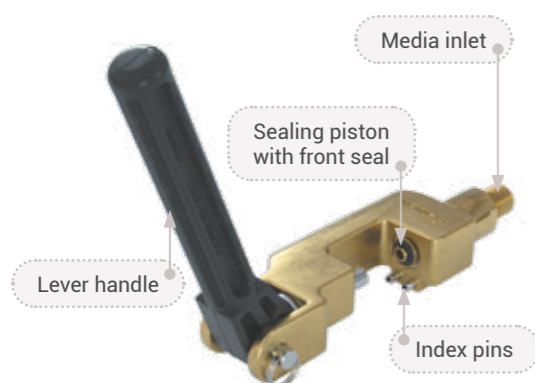

Features

- For Pin-Index connections acc. to CGA 870 (others on request)
- Version for cylinder valves with or without a residual pressure valve
- Super light → only 700 grams
- Open bow body for connection in seconds
- Pressure-assisted piston prevents accidental disconnection under pressure
- High-grade materials

The WEH® TW42 Quick connector is especially designed for filling gas cylinders with Pin-Index system (with or without a residual pressure valve). The connector is very light in weight and therefore easy to operate. Being open at one side the quick connector is easy to connect, especially to cylinder valves with large hand wheel and lateral gauge.

Simply place the connector body of the TW42 quick connector over the cylinder valve, align it with the index pins and move upwards. The pressure-tight connection is made.

The pressure-assisted piston prevents accidental disconnection under pressure and provides additional safety.

For gas cylinders with residual pressure valve the TW42 quick connector is additionally equipped with a RPV pin (see opposite picture) for opening the residual pressure valve.

This quick connector is available for gas cylinder valves acc. to CGA 870, others on request. Connectors for oxygen applications are oxygen cleaned and free of oil and grease.

Application

Quick connector for filling of gas cylinders with Pin-Index system (with or without a residual pressure valve).



RPV pin

TECHNICAL DATA

Characteristics	Basic version
Nominal bore (DN)	5 mm
Max. allowable operating pressure PS	250 bar
Temperature range	+5 °C up to +60 °C (O ₂)
Connection A	Pin-Index connection acc. to CGA 870 (others on request)
Medium	Medical oxygen (others on request)
Actuation	Manual actuation via lever handle
Material	Corrosion resistant stainless steel, brass
Sealing material	EPDM (others on request)
Design	With or without RPV pin
Conformity / Tests / Approvals	Type approval for suitability against adiabatic compression available

Other designs on request

Example of use:



» WEH® Connector TW42

ORDERING | WEH® TW42 Quick connector

approx. dimensions (mm)

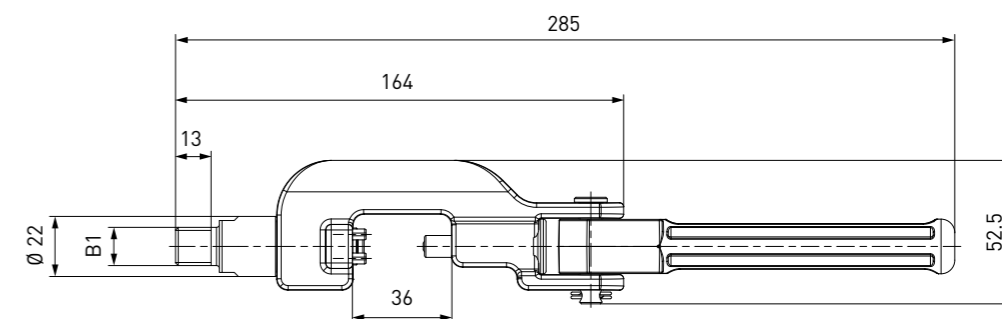

Part No.	Description	A	B1 (male thread)
C1-117833-X01	TW42	CGA 870	NPT 1/4"
C1-117834-X01*	TW42	CGA 870	NPT 1/4"

* with RPV pin

Other connection sizes and types on request.

Required information for ordering see page 7.

ACCESSORIES

The following accessories are available for the WEH® TW42 Quick connector:

Swivel joint WEH® TD1 (see page 58)

Pressure hose WEH® THP40 (see page 68)

Adaptors

Adaptors for connecting the quick connector to the filling hose are available on request.

Monel® construction

All pressurized parts are also available in Monel®. Please contact us!

SPARE PARTS

Various parts are available as spares for the WEH® TW42 Quick connector.

Part No.	Description
E50-55668	O-ring

» WEH® Connector TW53

DESCRIPTION

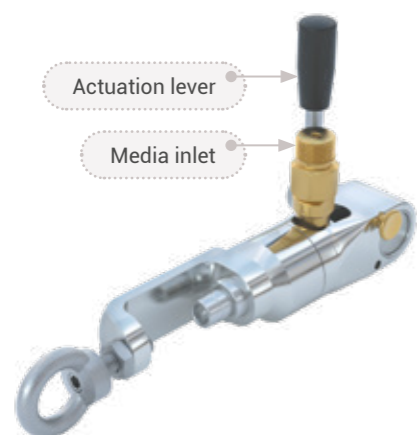

Features

- Suitable for filling of acetylene and acetone
- Connection in seconds
- No hand tightening required
- Integrated shut-off valve
- Robust construction
- High-grade materials

The WEH® TW53 Quick connector introduces a new generation of connector systems for the industrial filling of acetylene and acetone for cylinder valves acc. to DIN 477 part 1 no. 3. The TW53 is connected to the gas cylinder valve like a conventional filling device but eliminates screw tightening.

Simply place the TW53 quick connector around the cylinder valve, turn the actuation lever down and the pressure-tight connection is made.

For ease of operating an optional swivel joint is available to be mounted to the media inlet port.

No additional valves required

The integrated shut-off valve prevents the leakage of gas when connecting and disconnecting. A check valve at the inlet of the TW53 prevents the loss of gas in case of damage to the filling valve (flame barrier). The amount of vented gas when disconnecting is always less than 1 cm³ at 1 bar.

Safety tested

The TW53 quick connector is BAM tested and meets the requirements of the technical regulations for acetylene plants (TRAC).

Application

Quick connector for filling of gas cylinders with acetylene and acetone on connection acc. to DIN 477 part 1 no. 3

TECHNICAL DATA

Characteristics	Basic version
Nominal bore (DN)	2.5 mm
Max. allowable operating pressure PS	30 bar
Temperature range	+10 °C up to +60 °C
Connection A	Connection acc. to DIN 477 part 1 no. 3
Medium	Acetylene / acetone
Actuation	Manual actuation via actuation lever
Material	Corrosion resistant stainless steel, brass
Sealing material	EPDM
Conformity / Tests / Approvals	Detonative acetylene decomposition test up to 315 bar

Other designs on request

Example of use:



» WEH® Connector TW53

ORDERING | WEH® TW53 Quick connector

approx. dimensions (mm)

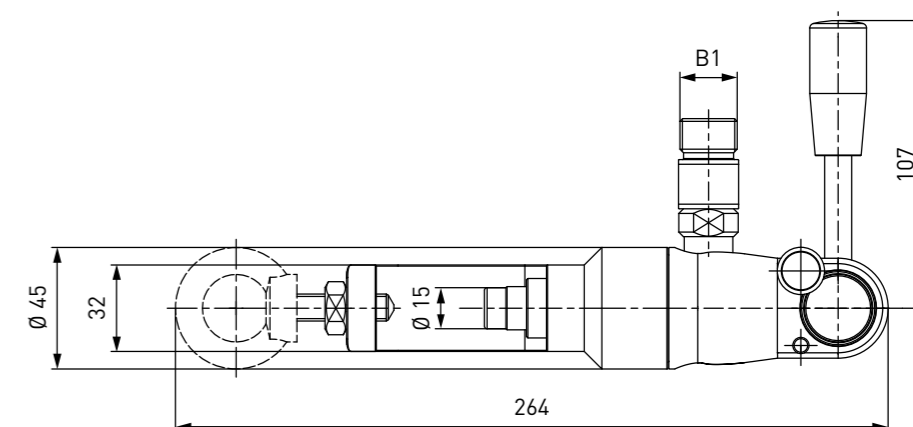

Part No.	Description	A	B1 (male thread)
C1-4419	TW53	DIN 477 part 1 no. 3	G1/2"

Other connection sizes and types on request.

Required information for ordering see page 7.

ACCESSORIES

The following accessories are available for the WEH® TW53 Quick connector:

Swivel joint WEH® TD1 (see page 58)

» WEH® Connector TW59

DESCRIPTION



Features

- Suitable for filling of propane and butane
- Connection in seconds
- No hand tightening required
- Integrated shut-off valve
- WEH® Jaw locking mechanism
- Single-handed operation
- Robust construction
- High-grade materials

The WEH® TW59 Quick connector is specifically designed for the filling of gas cylinders with propane and butane.

Type TW59 provides an intrinsically safe connection. The seal between the quick connector and the gas cylinder valve is mechanically actuated and the sealing force is increased by the gas filling pressure. This means that there is no need for a compressed air safety reservoir, the air supply is used to withdraw the seal when connecting / disconnecting in order to achieve effortless operation.

If needed, a second pneumatic inlet is provided for pilot pressure. This can be used to indicate the operational condition of the connector – i.e. whether connected or disconnected – and could for example be used to automatically begin the loading and unloading of the gas cylinders from the filling station.

No additional valves required

The integrated shut-off valve prevents the leakage of gas when connecting and disconnecting. The gas flow is immediately interrupted when disengaging the pressurized connector.

Safety tested

The type TW59 is TÜV tested and meets the requirements of the technical regulations for gases (TRG).

Application

Quick connector for filling of gas cylinders with propane and butane on connection acc. to DIN 477 part 1 Nr. 1 and 2

TECHNICAL DATA

Characteristics	Basic version
Nominal bore (DN)	16 mm
Max. allowable operating pressure PS	30 bar
Pilot pressure	6 - 8 bar
Pilot pressure port P1	M5
Pilot pressure port P2	M5 - if this feature is not required the port must be fitted with a blanking plug (factory fitted)
Temperature range	+5 °C up to +95 °C
Connection A	Connection acc. to DIN 477 part 1 no. 1 and 2
Medium	Propane, butane
Actuation	Manual actuation via sliding sleeve (pneumatically supported)
Material	Corrosion resistant stainless steel, aluminum
Sealing material	Acc. to gas type
Conformity / Tests / Approvals	TÜV test available

Example of use:



Other designs on request

» WEH® Connector TW59

ORDERING | WEH® TW59 Quick connector

approx. dimensions (mm)

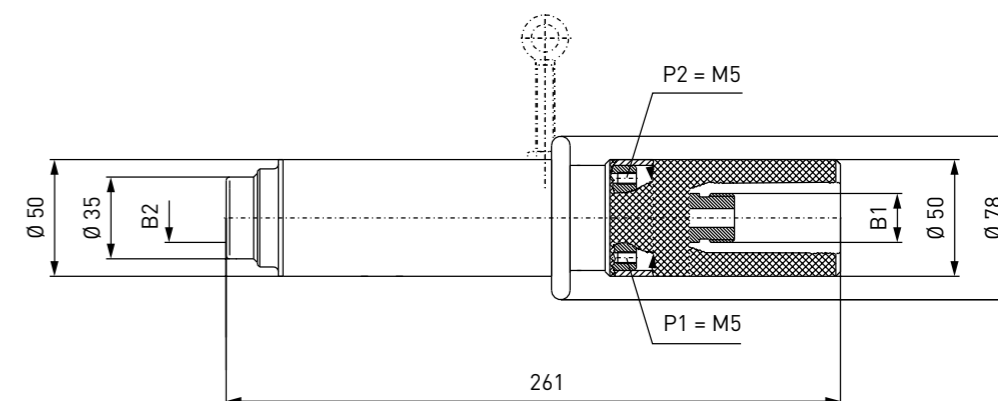

Part No.	Description	B1 (male thread)	B2 (male thread)
C1-10291	TW59	W21.8x1/14"* LH	W21.8x1/14"* LH

acc. to DIN 477 part 1

Other connection sizes and types on request.

Required information for ordering see page 7.

SPARE PARTS

Various parts are available as spares for the WEH® TW59 Quick connector.

Part No.	Description
E51-101N	Special seal

» WEH® Connector TW67

DESCRIPTION

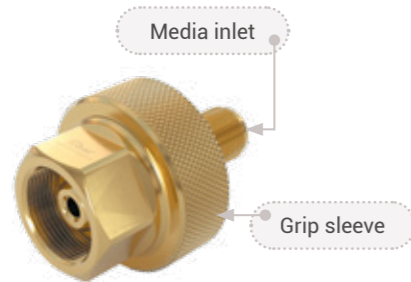

- Features**
- Version for cylinder valves with or without a residual pressure valve
 - Suitable for pallet and bundle filling
 - Inline or 90° version available
 - Compact design
 - High-grade materials

The WEH® TW67 Manual connector for male threads is simply screwed onto the cylinder valve and the pressure-tight connection is made.

The TW67 is suitable for gas cylinders with a nominal operating pressure of 200 bar resp. 300 bar and is available in four different designs: a short version for pallet filling and an extended version for bundle filling, optionally as inline or 90° version and in each case for cylinder valves with or without a residual pressure valve.



TW67 - inline
pallet filling



TW67 - 90°
pallet filling



TW67 - inline
bundle filling



TW67 - 90°
bundle filling

Application

Manual connector for filling of gas cylinders with male thread and with or without a residual pressure valve (pallet and bundle filling).

TECHNICAL DATA

Characteristics	Basic version
Max. allowable operating pressure PS	250 bar resp. 375 bar
Temperature range	+5 °C up to +80 °C +5 °C up to +60 °C (O ₂)
Connection A (cylinder valve)	Male thread connection acc. to the corresponding national standard e.g. DIN, CEN, CGA, BS, NF etc.
Medium	Inert/flammable gases, oxygen, argon, nitrogen
Actuation	Manual actuation via grip sleeve
Material	Brass
Sealing material	Acc. to gas type
Filling type	Pallet filling, bundle filling
Conformity / Tests / Approvals	Type approval for suitability against adiabatic compression available

Other designs on request

Example of use:



» WEH® Connector TW67

ORDERING | WEH® TW67 Manual connector with inline media inlet - pallet filling

approx. dimensions (mm)

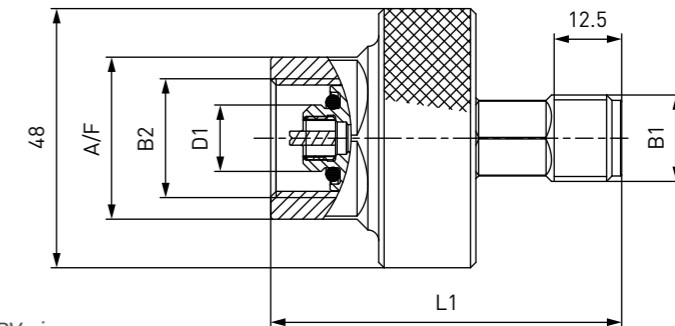

Example: TW67 with RPV pin



Part No.	B2 (female thread)	B1 (male thread)	Pressure (PS)	Medium	D1	L1	A/F
C1-94962-X01	W21,8 x1/14" DIN 477 Part 1	M16x1.5	250 bar	Argon	12.3	65	30
C1-95028	W21,8 x1/14"-LH DIN 477 Part 1	M16x1.5	250 bar	Flammable gases	12.3	65	30
C1-94992	W24,32 x1/14" DIN 477 Part 1	M16x1.5	250 bar	Nitrogen	12.3	65	30
C1-95039	W30x2 ISO 5145 1.FTSC Code 0170	M16x1.5	375 bar	Inert gases	15.9	68	36
C1-94996-X01	G3/4" DIN 477 Part 1	M16x1.5	250 bar	Oxygen	13.5	65	32
C1-98091	W30x2 ISO 5145 1.FTSC Code 4070	M16x1.5	375 bar	Oxygen	17.3	68	36
C1-94998*	W21,8 x1/14" DIN 477 Part 1	M16x1.5	250 bar	Argon	12.3	65	30
C1-95063*	W21,8 x1/14"-LH DIN 477 Part 1	M16x1.5	250 bar	Flammable gases	12.3	65	30
C1-94983-X01*	W24,32 x1/14" DIN 477 Part 1	M16x1.5	250 bar	Nitrogen	12.3	65	30
C1-95220*	W30x2 ISO 5145 1.FTSC Code 0170	M16x1.5	375 bar	Inert gases	15.9	68	36
C1-94995-X01*	G3/4" DIN 477 Part 1	M16x1.5	250 bar	Oxygen	13.5	65	32
C1-98090*	W30x2 ISO 5145 1.FTSC Code 4070	M16x1.5	375 bar	Oxygen	17.3	68	36

* with RPV pin

» WEH® Connector TW67

ORDERING | WEH® TW67 Manual connector with 90° media inlet - pallet filling

approx. dimensions (mm)

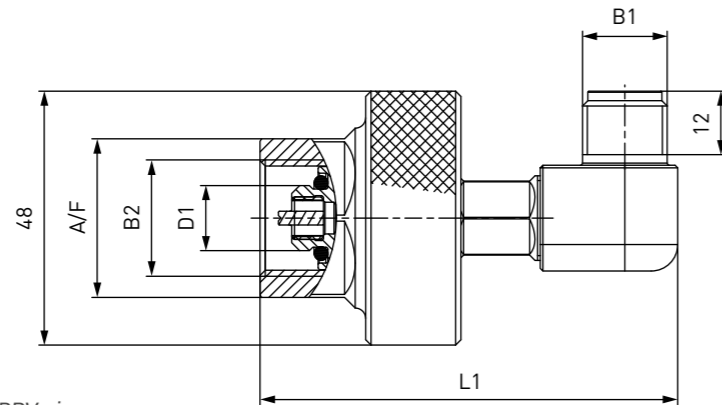

Example: TW67 with RPV pin



Part No.	B2 (female thread)	B1 (male thread)	Pressure (PS)	Medium	D1	L1	A/F
C1-93019-X01	W21,8 x1/14" DIN 477 Part 1	M16x1.5	250 bar	Argon	12.3	79	30
C1-92813-X01	W21,8 x1/14"- LH DIN 477 Part 1	M16x1.5	250 bar	Flammable gases	12.3	79	30
C1-92986-X01	W24,32 x1/14" DIN 477 Part 1	M16x1.5	250 bar	Nitrogen	12.3	79	30
C1-94098-X01	W30x2 ISO 5145 1.FTSC Code 0170	M16x1.5	375 bar	Inert gases	15.9	82	36
C1-93043-X01	G3/4" DIN 477 Part 1	M16x1.5	250 bar	Oxygen	13.5	78	32
C1-98089-X01	W30x2 ISO 5145 1.FTSC Code 4070	M16x1.5	375 bar	Oxygen	17.3	82	36
C1-93023-X01*	W21,8 x1/14" DIN 477 Part 1	M16x1.5	250 bar	Argon	12.3	79	30
C1-92855*	W21,8 x1/14"- LH DIN 477 Part 1	M16x1.5	250 bar	Flammable gases	12.3	79	30
C1-93009-X01*	W24,32 x1/14" DIN 477 Part 1	M16x1.5	250 bar	Nitrogen	12.3	79	30
C1-95221-X01*	W30x2 ISO 5145 1.FTSC Code 0170	M16x1.5	375 bar	Inert gases	15.9	82	36
C1-93047-X01*	G3/4" DIN 477 Part 1	M16x1.5	250 bar	Oxygen	13.5	79	32
C1-99758-X01*	W30x2 ISO 5145 1.FTSC Code 4070	M16x1.5	375 bar	Oxygen	17.3	82	36

* with RPV pin

» WEH® Connector TW67

ORDERING | WEH® TW67 Manual connector with inline media inlet - bundle filling

approx. dimensions (mm)

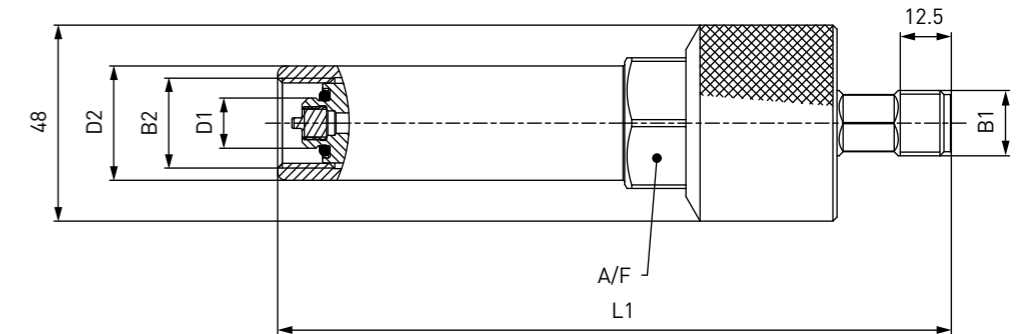

Example: TW67 with RPV pin



Part No.	B2 (female thread)	B1 (male thread)	Pressure (PS)	Medium	D1	D2	L1	A/F
C1-95101	W21,8 x1/14" DIN 477 Part 1	M16x1.5	250 bar	Argon	12.3	28	164	32
C1-95194	W21,8 x1/14"- LH DIN 477 Part 1	M16x1.5	250 bar	Flammable gases	12.3	28	164	32
C1-95202	W24,32 x1/14" DIN 477 Part 1	M16x1.5	250 bar	Nitrogen	12.3	30	164	32
C1-95111-X01	W30x2 ISO 5145 1.FTSC Code 0170	M16x1.5	375 bar	Inert gases	15.9	38	157	38
C1-95216	G3/4" DIN 477 Part 1	M16x1.5	250 bar	Oxygen	13.5	32	164	32
C1-98092	W30x2 ISO 5145 1.FTSC Code 4070	M16x1.5	375 bar	Oxygen	17.3	38	157	38
C1-95110*	W21,8 x1/14" DIN 477 Part 1	M16x1.5	250 bar	Argon	12.3	28	165	32
C1-95196*	W21,8 x1/14"- LH DIN 477 Part 1	M16x1.5	250 bar	Flammable gases	12.3	28	165	32
C1-95199*	W24,32 x1/14" DIN 477 Part 1	M16x1.5	250 bar	Nitrogen	12.3	30	165	32
C1-95223*	W30x2 ISO 5145 1.FTSC Code 0170	M16x1.5	375 bar	Inert gases	15.9	38	167	38
C1-95219*	G3/4" DIN 477 Part 1	M16x1.5	250 bar	Oxygen	13.5	32	165	32
C1-98093*	W30x2 ISO 5145 1.FTSC Code 4070	M16x1.5	375 bar	Oxygen	17.3	38	157	38

* with RPV pin

» WEH® Connector TW67

ORDERING | WEH® TW67 Manual connector with 90° media inlet - bundle filling

approx. dimensions (mm)

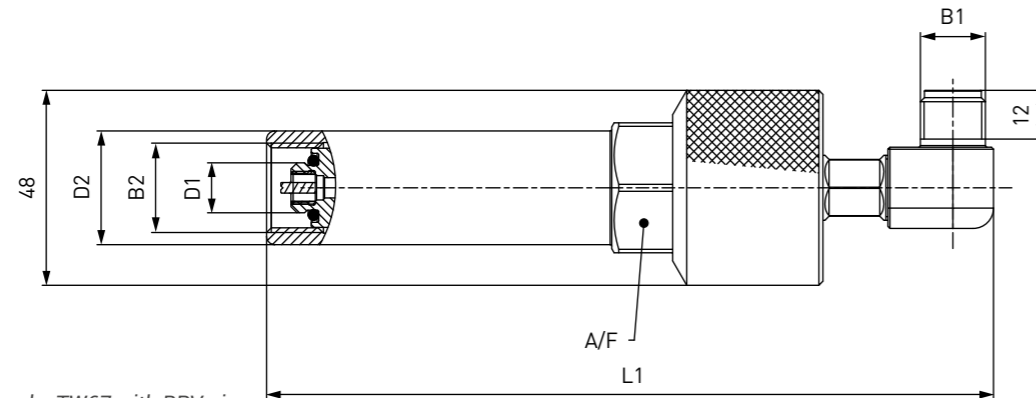

Example: TW67 with RPV pin



Part No.	B2 (female thread)	B1 (male thread)	Pressure (PS)	Medium	D1	D2	L1	A/F
C1-95081-X01	W21,8 x1/14" DIN 477 Part 1	M16x1.5	250 bar	Argon	12.3	28	178	32
C1-95195-X01	W21,8 x1/14"-LH DIN 477 Part 1	M16x1.5	250 bar	Flammable gases	12.3	28	178	32
C1-95203-X01	W24,32 x1/14" DIN 477 Part 1	M16x1.5	250 bar	Nitrogen	12.3	30	178	32
C1-95080-X01	W30x2 ISO 5145 1.FTSC Code 0170	M16x1.5	375 bar	Inert gases	15.9	38	173	38
C1-95215-X01	G3/4" DIN 477 Part 1	M16x1.5	250 bar	Oxygen	13.5	32	178	32
C1-98094-X01	W30x2 ISO 5145 1.FTSC Code 4070	M16x1.5	375 bar	Oxygen	17.3	38	171	38
C1-95082-X01*	W21,8 x1/14" DIN 477 Part 1	M16x1.5	250 bar	Argon	12.3	28	179	32
C1-95197*	W21,8 x1/14"-LH DIN 477 Part 1	M16x1.5	250 bar	Flammable gases	12.3	28	179	32
C1-95198-X01*	W24,32 x1/14" DIN 477 Part 1	M16x1.5	250 bar	Nitrogen	12.3	30	179	32
C1-95224-X01*	W30x2 ISO 5145 1.FTSC Code 0170	M16x1.5	375 bar	Inert gases	15.9	38	171	32
C1-95218-X01*	G3/4" DIN 477 Part 1	M16x1.5	250 bar	Oxygen	13.5	32	179	32
C1-98095-X01*	W30x2 ISO 5145 1.FTSC Code 4070	M16x1.5	375 bar	Oxygen	17.3	38	171	38

* with RPV pin

Other connection sizes and types on request.

Required information for ordering see page 7.

» WEH® Connector TW67

ACCESSORIES

The following accessories are available for the WEH® TW67 Manual connector:

Swivel joint WEH® TD1 (see page 58)

Quick release coupling WEH® TK350-TN350 (see page 60)

Grip extension with o-ring



Part no.	Description	B1 (male thread)	B2 (female thread)
W95076	Grip extension 50 mm	M16x1.5	M16x1.5
W104260	Grip extension 132 mm	M16x1.5	M16x1.5
W95332	Grip extension 231 mm	M16x1.5	M16x1.5

Adaptors

Adaptors for connecting the manual connector to the filling hose are available on request.

» WEH® Connector TW640

DESCRIPTION



Features

- Version optionally with straight or 90° media inlet
- Suitable for pallet filling
- Compact design
- High-grade materials

The WEH® TW640 Manual connector has been specially developed for pallet filling of gas cylinders with female threads. The TW640 is simply placed into the cylinder valve and tightened by hand until the o-ring seal contacts the counterpart. Now the pressure-tight connection is made. Thanks to the pressure support, the manual connector seals without wrenches, sealants or tape, thus saving connection times and costs.

The WEH® TW640 Manual connector is optionally available with an inline or angled media inlet:



TW640-S1



TW640-S2

Application

Manual connector with pressure support for filling of gas cylinders with female thread (suitable for pallet filling).

TECHNICAL DATA

Characteristics	Basic version
Nominal bore (DN)	5 mm
Max. allowable operating pressure PS	375 bar
Temperature range	+5 °C up to +60 °C
Connection A (cylinder valve)	Female thread connection acc. to the corresponding national standard e.g. DIN, CEN, CGA, BS, NF etc.
Medium	Inert gases*, oxygen
Actuation	Manual actuation via grip sleeve
Material	Corrosion resistant
Sealing material	EPDM
Filling type	Pallet filling
Conformity / Tests / Approvals	Type approval for suitability against adiabatic compression available

* Inert gases are all noble gases and nitrogen.

Other gases which are also considered inert under certain circumstances (e.g. CO₂, sulfur hexafluoride) must not be used with the WEH® Product without consulting WEH!

Other designs on request

» WEH® Connector TW640

OVERVIEW PRODUCT SERIES

Product series	Medium		Design	
	Inert gases	Oxygen	Inline	90°
TW640-S1	X	X	X	
TW640-S2	X	X		X

ORDERING | WEH® TW640-S1 Manual connector - with inline media inlet

approx. dimensions (mm)

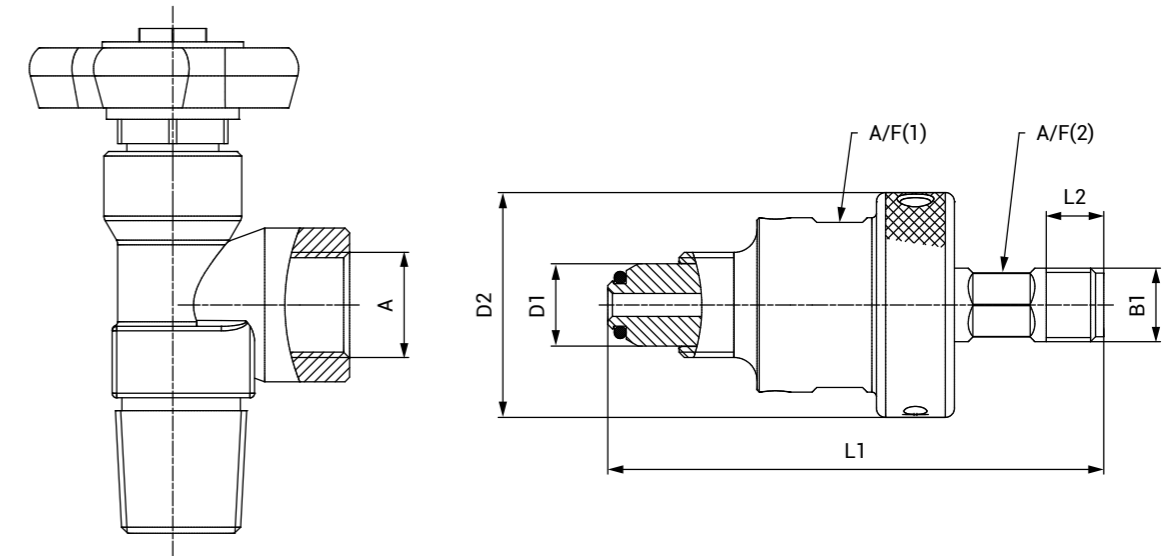

Part no.	A (female thread)	B1 (male thread)	Pressure (PS)	Medium	L1	L2	D1	D2	A/F(1)	A/F(2)
C1-177704	G5/8"	M16x1.5	375 bar	Inert gases	108	12.5	18	49	36	14
C1-172365	G5/8"	M16x1.5	375 bar	Oxygen	108	12.5	18	49	36	14

» WEH® Connector TW640

ORDERING | WEH® TW640-S2 Manual connector - with 90° media inlet

approx. dimensions (mm)

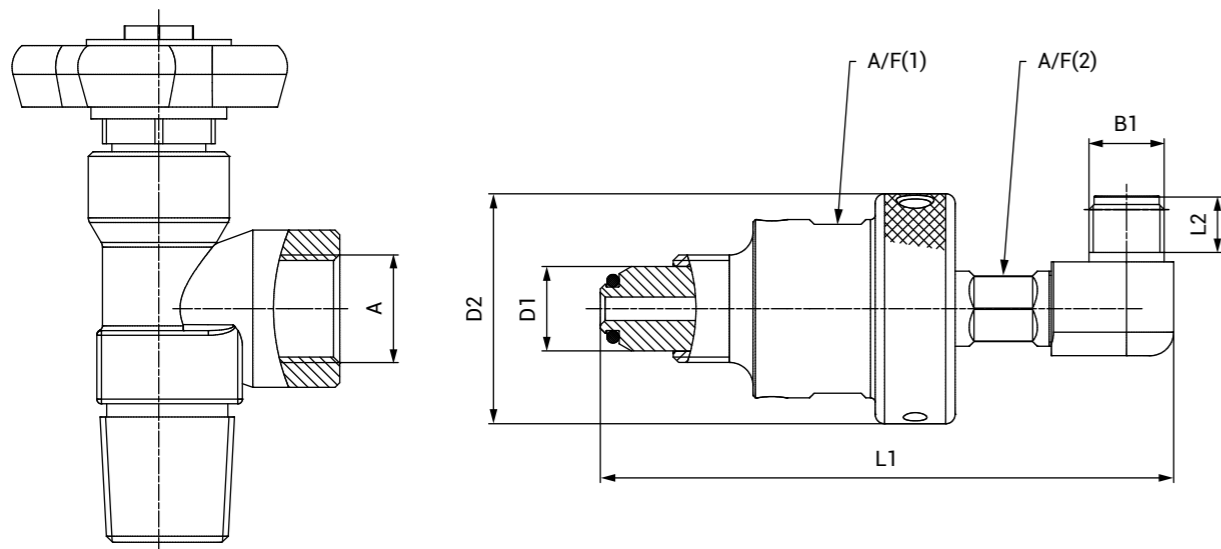

Part no.	A (female thread)	B1 (male thread)	Pressure (PS)	Medium	L1	L2	D1	D2	A/F(1)	A/F(2)
C1-177705	G5/8"	M16x1.5	375 bar	Inert gases	122	12	18	49	36	14
C1-176147	G5/8"	M16x1.5	375 bar	Oxygen	122	12	18	49	36	14

Other connection sizes and types on request.

Required information for ordering see page 7.

» WEH® Connector TW640

ACCESSORIES

The following accessories are available for the WEH® TW640 Manual connector:

Swivel joint WEH® TD1 (see page 58)

Quick release coupling WEH® TK350-TN350 (see page 60)

Grip extension with o-ring



Part no.	Description	B1 (male thread)	B2 (female thread)
W95076	Grip extension 50 mm	M16x1.5	M16x1.5
W104260	Grip extension 132 mm	M16x1.5	M16x1.5
W95332	Grip extension 231 mm	M16x1.5	M16x1.5

Adaptors

Adaptors for connecting the manual connector to the filling hose are available on request.

» WEH® Connector TW670

DESCRIPTION



Features

- Version optionally with straight or 90° media inlet
- Suitable for pallet filling
- Compact design
- High-grade materials

The WEH® TW670 Manual connector has been specially developed for pallet filling of gas cylinders with male threads. The TW670 is simply placed onto the cylinder valve and tightened by hand until the o-ring seal contacts the counterpart. Now the pressure-tight connection is made.

Thanks to the pressure support, the manual connector seals without wrenches, sealants or tape, thus saving connection times and costs.

The WEH® TW670 Manual connector is optionally available with an inline or angled media inlet:



TW670-S1



TW670-S2

Application

Manual connector with pressure support for filling of gas cylinders with male thread (suitable for pallet filling).

TECHNICAL DATA

Characteristics	Basic version
Nominal bore (DN)	5 mm
Max. allowable operating pressure PS	375 bar
Temperature range	+5 °C up to +60 °C
Connection A (cylinder valve)	Male thread connection acc. to the corresponding national standard e.g. DIN, CEN, CGA, BS, NF etc.
Medium	Inert gases*, oxygen
Actuation	Manual actuation via grip sleeve
Material	Corrosion resistant
Sealing material	EPDM
Filling type	Pallet filling
Conformity / Tests / Approvals	Type approval for suitability against adiabatic compression available

* Inert gases are all noble gases and nitrogen.

Other gases which are also considered inert under certain circumstances (e.g. CO₂, sulfur hexafluoride) must not be used with the WEH® Product without consulting WEH!

Other designs on request

» WEH® Connector TW670

OVERVIEW PRODUCT SERIES

Product series	Medium		Design	
	Inert gases	Oxygen	Inline	90°
TW670-S1	X	X	X	
TW670-S2	X	X		X

ORDERING | WEH® TW670-S1 Manual connector - with inline media inlet

approx. dimensions (mm)

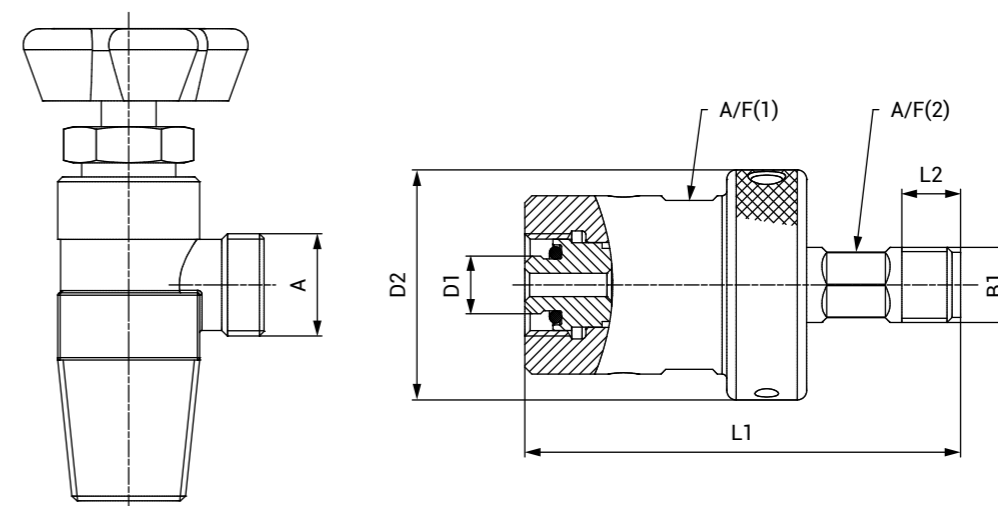

Part no.	A (female thread)	B1 (male thread)	Pressure (PS)	Medium	L1	L2	D1	D2	A/F(1)	A/F(2)
C1-177706	W21.8x1/14"	M16x1.5	375 bar	Inert gases	93	12.5	12,3	49	36	14
C1-172367	W21.8x1/14"	M16x1.5	375 bar	Oxygen	93	12.5	12,3	49	36	14

» WEH® Connector TW670

ORDERING | WEH® TW670-S2 Manual connector - with 90° media inlet

approx. dimensions (mm)

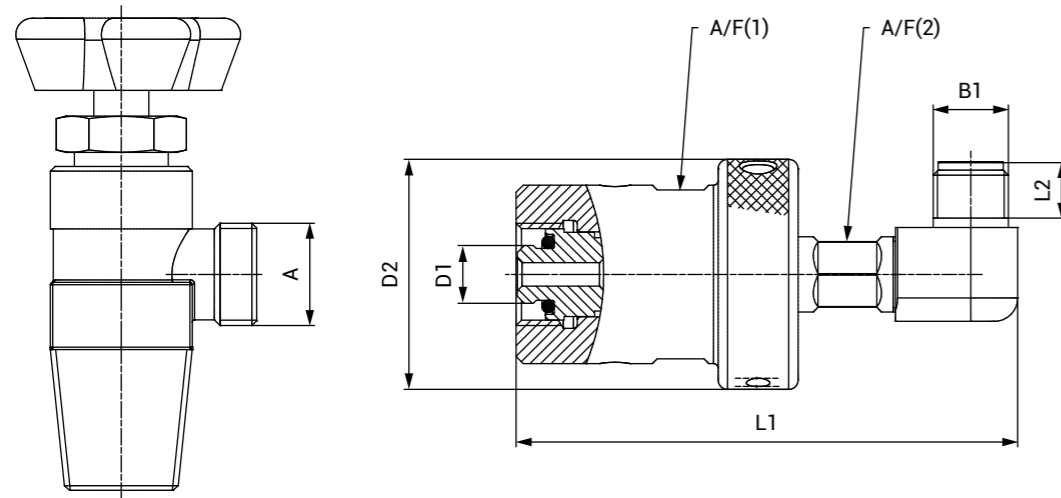

Part no.	A (female thread)	B1 (male thread)	Pressure (PS)	Medium	L1	L2	D1	D2	A/F(1)	A/F(2)
C1-177707	W21.8x1/14"	M16x1.5	375 bar	Inert gases	107	12	12.3	49	36	14
C1-176075	W21.8x1/14"	M16x1.5	375 bar	Oxygen	107	12	12.3	49	36	14

Other connection sizes and types on request.

Required information for ordering see page 7.

» WEH® Connector TW670

ACCESSORIES

The following accessories are available for the WEH® TW670 Manual connector:

Swivel joint WEH® TD1 (see page 58)

Quick release coupling WEH® TK350-TN350 (see page 60)

Grip extension with o-ring

B2  B1	Part no.	Description	B1 (male thread)	B2 (female thread)
		W95076	Grip extension 50 mm	M16x1.5
	W104260	Grip extension 132 mm	M16x1.5	M16x1.5
	W95332	Grip extension 231 mm	M16x1.5	M16x1.5

Adaptors

Adaptors for connecting the manual connector to the filling hose are available on request.

» WEH® Connector TW17

DESCRIPTION

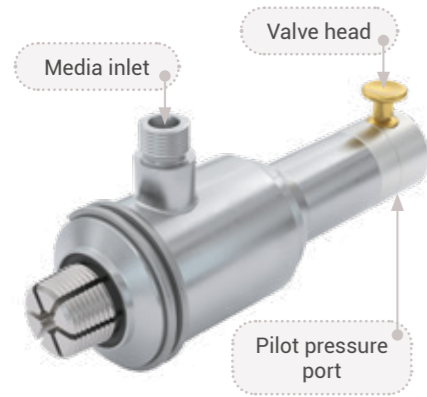

Features

- Suitable for water pressure testing of gas cylinders
- Connection in seconds
- No hand tightening required
- Different actuations
- WEH® Jaw locking mechanism
- Robust construction
- High-grade materials

The WEH® TW17 Quick connector offers time saving on pressure testing of gas cylinders by eliminating tedious manual threading.

Depress the valve head and simply push the TW17 quick connector into the female thread of the gas cylinder. Release the valve head and the pressure-tight connection is made. The cylinder can now be leak tested with water. The test procedure is regulated by an external control unit.

Application

Quick connector for pressure testing of gas cylinders with water.

TECHNICAL DATA

Characteristics	Basic version
Max. allowable operating pressure PS	350 bar
Pilot pressure	6 - 8 bar air
Temperature range	+5 °C up to +80 °C
Medium	Water
Actuation	Pneumatic actuation via valve head or manual actuation via lever handle
Material	Corrosion resistant stainless steel, brass
Sealing material	NBR

Other designs on request

Example of use:



» WEH® Connector TW17

ORDERING | WEH® TW17 Quick connector with pneumatic actuation

approx. dimensions (mm)

TW17V for W19.8x1/14" connection

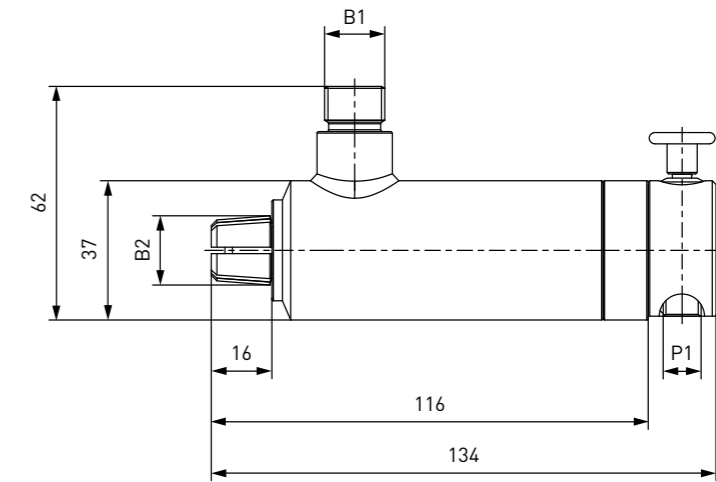

TW17V for W28.8x1/14" connection

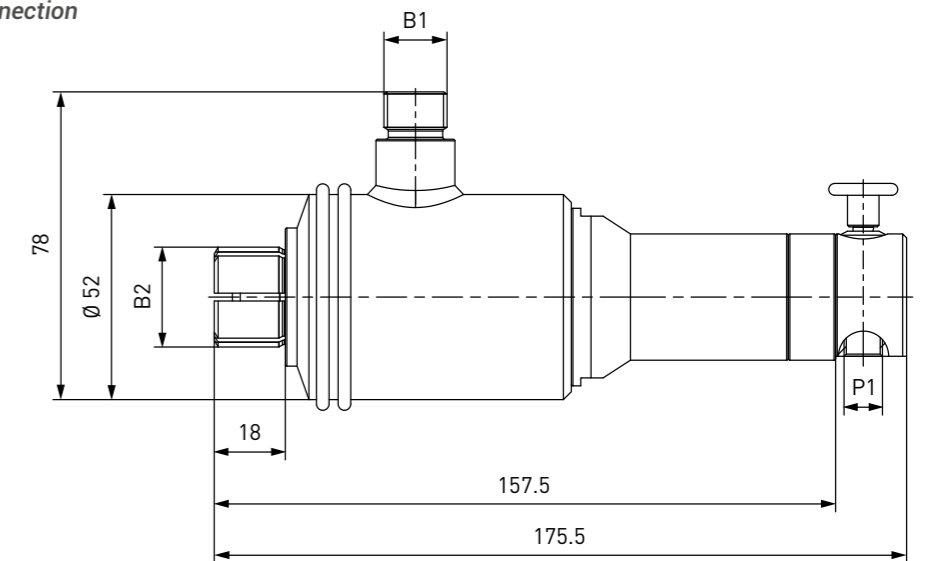

Part No.	Description	B1 (male thread)	B2 (male thread)	P1 (female thread)
C1-33210	TW17V	M16x1.5*	W19.8x1/14"	G1/8"
C1-30341	TW17V	M16x1.5*	W28.8x1/14"	G1/8"

* Ermeto 24° ,S'

» WEH® Connector TW17

ORDERING | WEH® TW17 Quick connector with manual actuation

approx. dimensions (mm)

TW17M for W28.8x1/14" connection

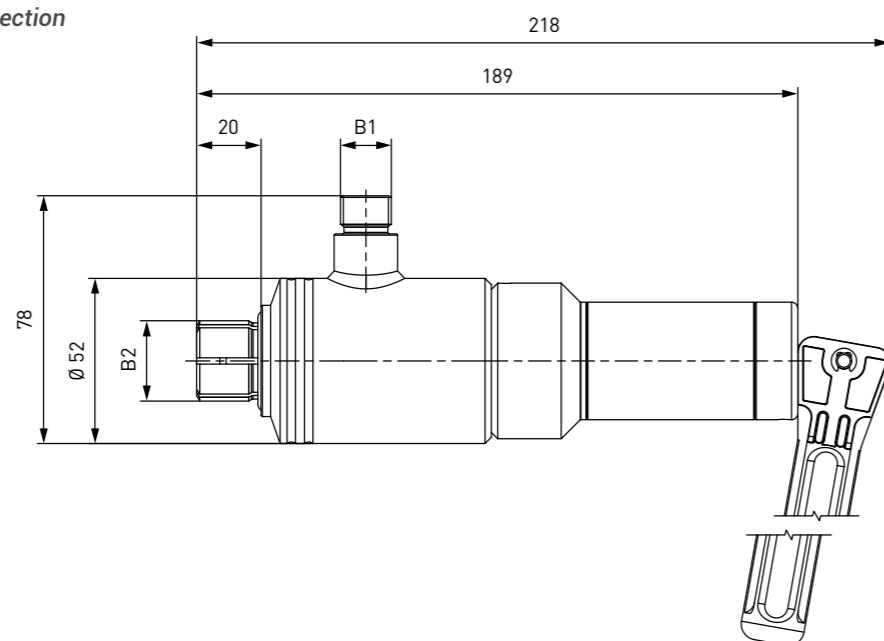

Part No.	Description	B1 (male thread)	B2 (male thread)
C1-14854	TW17M	M16x1.5*	W28.8x1/14"

* Ermeto 24° ,S'

Other connection sizes and types on request.

Required information for ordering see page 7.

» WEH® Connector TW17

ACCESSORIES

The following accessories are available for the WEH® TW17 Quick connector:

Actuations

For type TW17 various manual and pneumatic actuations are available:

- H (manually via hand lever)
- M (manually via lever handle)
- V (pneumatically via valve head)
- P (pneumatically for external control systems)

Please contact us!

SPARE PARTS

Various parts are available as spares for the WEH® TW17 Quick connector.

Part No.	Description
E50-135N	O-ring for C1-33210
E50-231N	O-ring for C1-30341 and C1-14854

» WEH® Connector TW117

DESCRIPTION



Features

- Three functions with one connection: filling - testing - discharging of/with water
- Connection in seconds
- No hand tightening required
- WEH® Jaw locking mechanism
- Robust construction
- High-grade materials

The WEH® TW117 Quick connector simplifies testing of gas cylinders with water. Eliminating tedious screwing and un-screwing of threaded parts saves time and money and also spares the employees muscles and joints. The quick connector is easy to connect and disconnect with a single-handed operation. The most impressive features are the high functionality and range of applications of TW117.

Three functions with one connection: filling, testing and discharging of gas cylinders with water (discharging can also be carried out with compressed air).

A green visual ring (see example of use) shows when the connector has been properly connected.

For pressure tests, the lateral inlet 'B2' has to be sealed with a high pressure screw plug or a ball valve. Please contact us!

Application

Quick connector for testing of gas cylinders with water.

TECHNICAL DATA

Characteristics	Basic version
Max. allowable operating pressure PS	450 bar
Pilot pressure	6 - 8 bar air
Pilot pressure port P1	M5
Temperature range	+10 °C up to +80 °C
Medium	Water, compressed air (when discharging)
Actuation	Pneumatic actuation via valve head
Material	Corrosion resistant stainless steel, aluminum, brass
Sealing material	NBR

Other designs on request

Example of use:

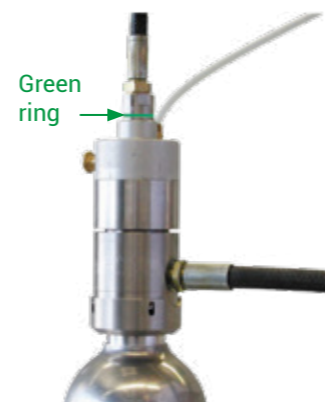

» WEH® Connector TW117

ORDERING | WEH® TW117 Quick connector

approx. dimensions (mm)

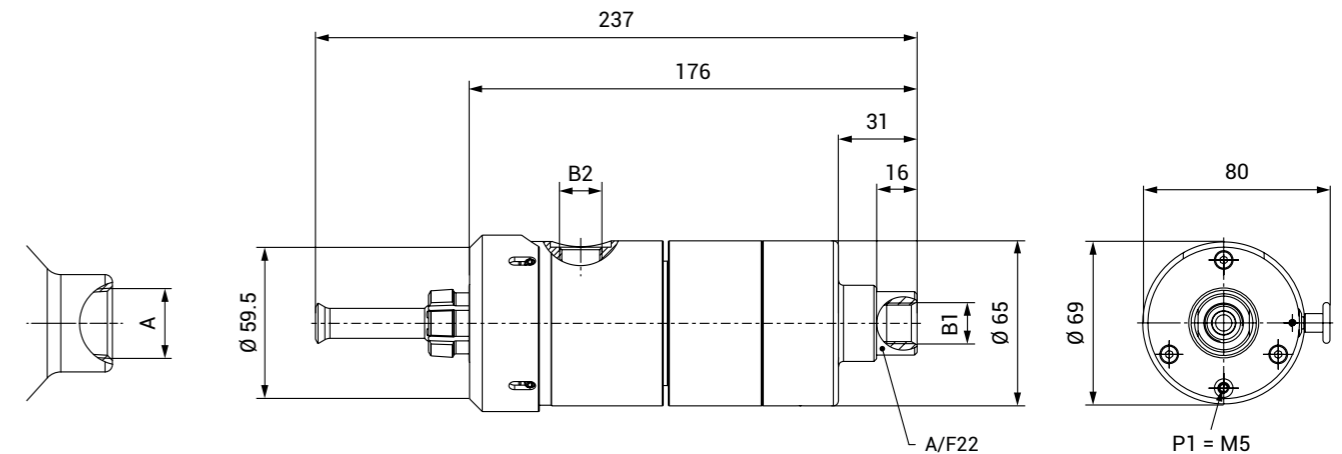

Part No.	Description	A (female thread)	B1 (female thread)	B2 (female thread)
C1-11673	TW117	W28.8x1/14"	M16x1.5	G3/8"

* acc. to DIN 477

Other connection sizes and types on request.

Required information for ordering see page 7.

ACCESSORIES

The following accessories are available for the WEH® TW117 Quick connector:

Adaptors

Adaptors for connecting the quick connector to the filling hose are available on request.

SPARE PARTS

Various parts are available as spares for the WEH® TW117 Quick connector.

Part No.	Description
E50-231N	Front seal
B200B-056-00	Seal set

» Swivel joint TD1

DESCRIPTION



Features

- For free rotation of the WEH® Connector / filling hose in each position
- No twisting of the filling hose
- Version for inert gases and oxygen
- High-quality materials

The WEH® TD1 Swivel joint is the ideal addition for any application where a WEH® Connector can be placed in the optimum connection position without pressure. This prevents the filling hose from twisting.

The swivel joint is simply screwed onto the corresponding WEH® Connector.

The WEH® TD1 is equipped with a seal adapted to the medium. Other sealing materials are available on request. It is the customer's responsibility to clarify the media compatibility.

Application

Swivel joint for axial alignment of the WEH® Connector.

TECHNICAL DATA

Characteristics	Basic version
Nominal bore (DN)	5 mm
Max. allowable operating pressure PS	420 bar
Temperature range	+5 °C up to +80 °C +5 °C up to +60 °C (O ₂)
Medium	Inert gases and oxygen
Material	Brass
Sealing material	Depending on medium
Conformity / Tests / Approvals	Type approval for suitability against adiabatic compression available

Other designs on request

Example of use:



» Swivel joint TD1

ORDERING | WEH® TD1 Swivel joint

approx. dimensions (mm)

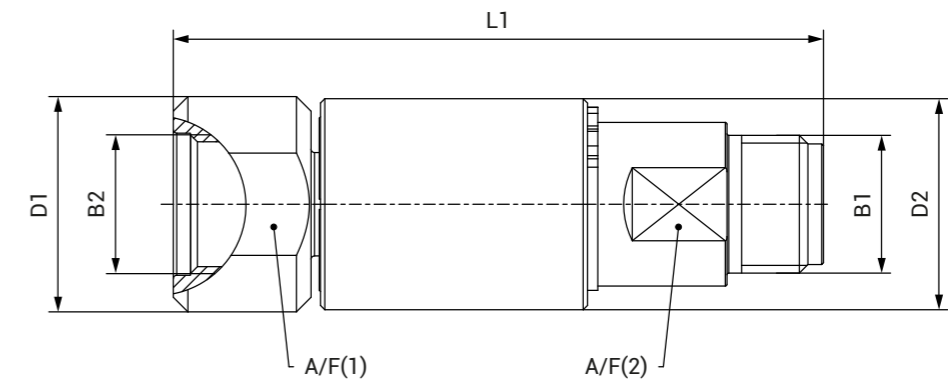

Part no.	Description	B1 (male thread)	B2 (female thread)	L1	D1	D2	A/F(1)	A/F(2)
W6996-X01	TD1	M16x1.5	M16x1.5	75.5	25	24.5	22	17

Other connection sizes and types on request.

Required information for ordering see page 7.

ACCESSORIES

The following accessories are available for the WEH® TD1 Swivel joint:

Adaptors

Adaptors for connecting the TD1 swivel joint (port B1) to the filling hose are available on request.

SPARE PARTS

Various parts are available as spares for the WEH® TD1 Swivel joint.

Part no.	Description
E50-139S614	Seal

» Quick release system TK350-TN350

DESCRIPTION

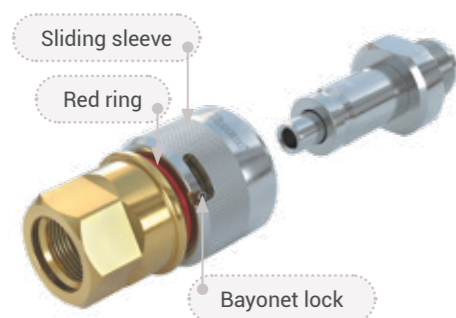

Features

- Quick connector change
- Bayonet lock
- Suitable for inert gases and oxygen
- Can be used as swivel joint
- High-quality materials

Previously, when gas cylinders were filled with different cylinder valves, the filling hose had to be unscrewed each time from the quick connector and screwed onto a different connector. The quick release system has solved this problem. The WEH® TK350-TN350 Quick release system allows a quick change of a WEH® Connector for repairs or when changing to other cylinder valve standards. Changing from residual pressure to non-residual pressure connectors is also made much easier. An additional swivel joint is not required, as the quick release system can also be used for this purpose.

The quick release system consists of a WEH® TK350 Quick release coupling (without shut-off valve) for direct connection to the WEH® Connectors TW54, TW57, TW67, TW640 and TW670 and a WEH® TN350 Quick release nipple (without shut-off valve) for connection to the filling hose.

The TK350 quick release coupling is screwed directly onto the WEH® Connector and the corresponding TN350 quick release nipple is screwed to the filling hose. When changing to a different cylinder valve configuration, disconnect the TK350 and TN350 by unlocking the bayonet lock and pulling back the sliding sleeve of the TK350. The TN350 quick release nipple remains on the filling hose and is simply connected to another WEH® Connector, which is also equipped with a TK350 quick release coupling. This allows quick change from one system to another.

The WEH® TK350 Quick release coupling has a red ring as a visual check, which indicates whether the quick release coupling is connected correctly and a bayonet lock which prevents the coupling from disconnecting by itself.

The WEH® TK350-TN350 is equipped with a seal adapted to the medium. Other sealing materials are available on request. It is the customer's responsibility to clarify the media compatibility.

Application

Quick release system for fast and easy changing of WEH® Connectors for repairs, for changing to other standards and for changing from residual pressure to non-residual pressure connectors.

TECHNICAL DATA

Characteristics	Basic version
Nominal bore (DN)	5 mm
Max. allowable operating pressure PS	375 bar
Temperature range	+5 °C up to +80 °C +5 °C up to +60 °C (O ₂)
Leak rate	1 x 10 ⁻³ mbar x l/s
Medium	Inert gases and oxygen
Material	Corrosion resistant TK350: brass and stainless steel TN350: stainless steel
Sealing material	Depending on medium
Actuation	Manual actuation via sliding sleeve
Conformity / Tests / Approvals	Type approval for suitability against adiabatic compression available

Other designs on request

Example of use:



» Quick release system TK350-TN350

SYSTEM OVERVIEW

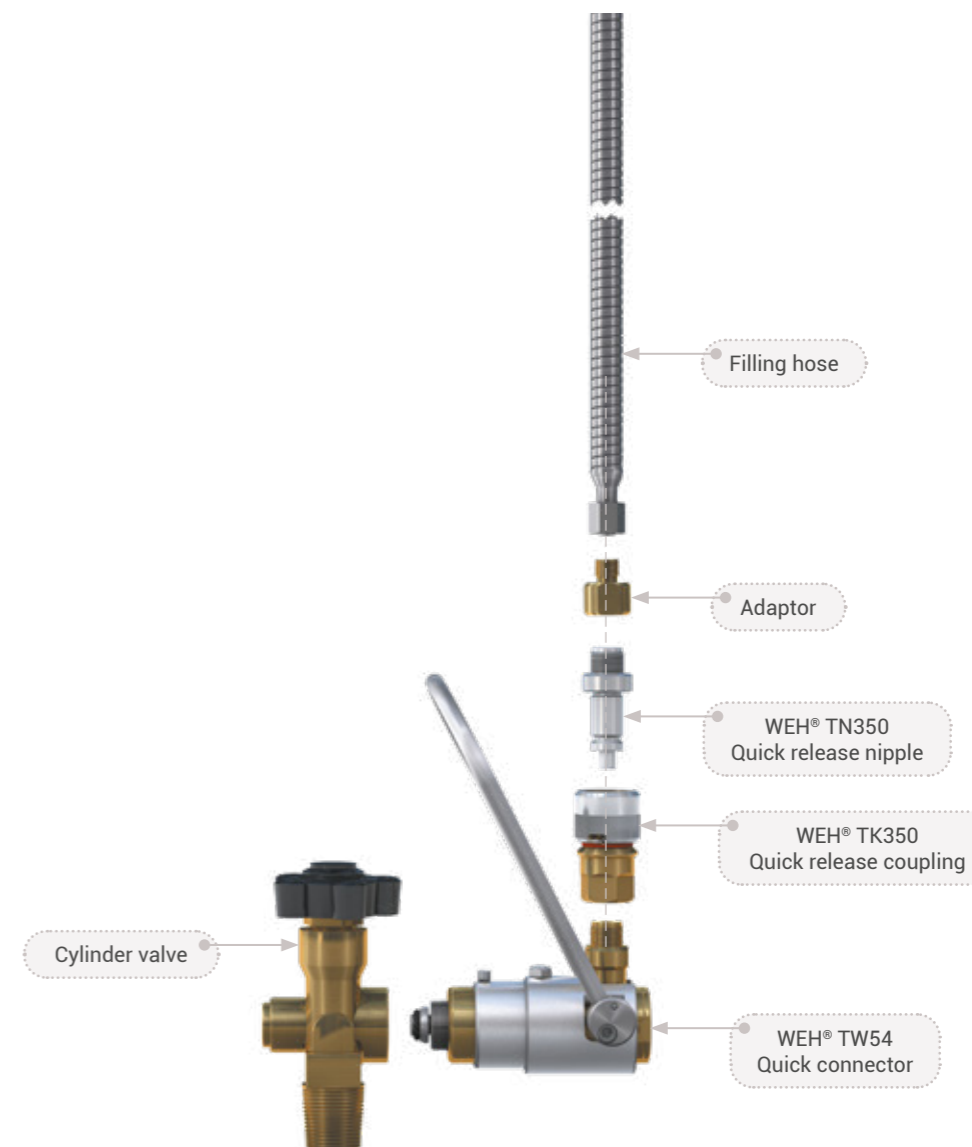

» Quick release system TK350-TN350

ORDERING | WEH® TK350 Quick release coupling

approx. dimensions (mm)

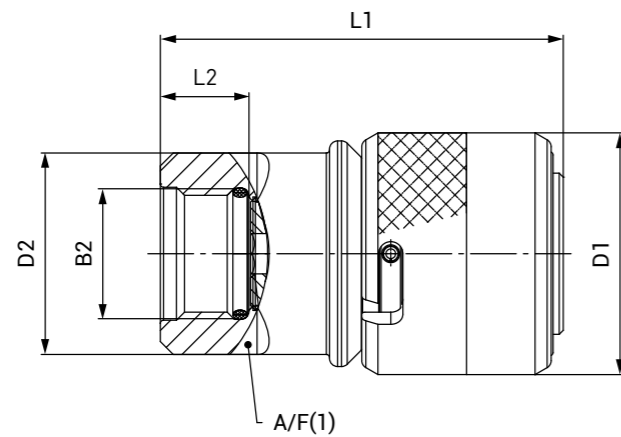

Part no.	Description	B2 (female thread)	L1	L2	D1	D2	A/F(1)
C1-91239-X01	TK350	M16x1.5	50	11	30	25	22

ORDERING | WEH® TN350 Quick release nipple

approx. dimensions (mm)

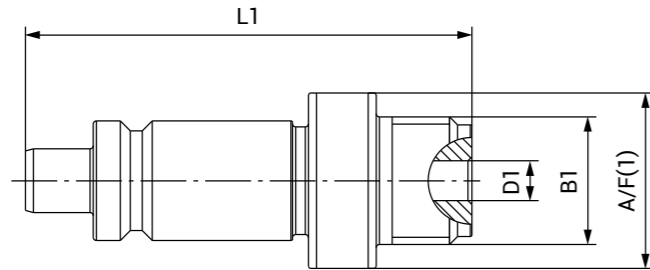

Part no.	Description	B1 (male thread)	L1	D1	A/F(1)
C1-91241-X01	TN350	M16x1.5	56	5	22

Other connection sizes and types on request.

Required information for ordering see page 7.

» Quick release system TK350-TN350

ACCESSORIES

The following accessories are available for the WEH® TK350-TN350 Quick release system:

Adaptors

Adaptors for connecting the TN350 quick release nipple to the filling hose are available on request.

Monel® construction

All pressurized parts are also available in Monel®. Please contact us!

» Check valve TVR2

DESCRIPTION



Features

- High leak tightness
- Very low noise due to optimized internal gas flow
- Wear and corrosion resistant
- Robust construction
- Simple installation
- High-quality materials

The WEH® TVR2 Check valve was specially developed for installation in gas mixing plants.

The internal seals are arranged so that they are protected from the media flow. This prevents damage to the seals from any dirt particles on the sealing components within the unit.

The check valves, which are very silent in use even under high flow rates, are characterized in particular by their very low cracking pressure and their optimum tightness, which makes them ideal for use with gaseous media.

The WEH® TVR2 is equipped with a EPDM housing seal. Other sealing materials are available on request. It is the customer's responsibility to clarify the media compatibility.

Application

Check valve for reliable return flow prevention in a gaseous media flow and for installation in gas mixing plants.

Attention: The TVR2 is not designed to be used as a filling or safety valve!

TECHNICAL DATA

Characteristics	Basic version
Nominal bore (DN)	12 mm
Max. allowable operating pressure PS	420 bar
Temperature range	+5 °C up to +95 °C
Medium	Inert gases
Material	Housing of brass, inner parts of stainless steel
Spring material	Stainless spring steel
Sealing material	Housing seal of EPDM
Sealing concept	Cone sealing with PEEK
Flow direction	B1 → B2

Other designs on request

Example of use:

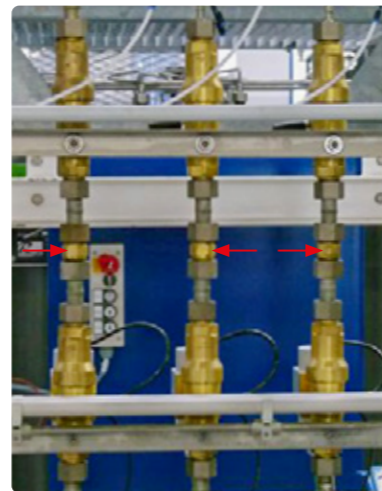

» Check valve TVR2

ORDERING | WEH® TVR2 Check valve

approx. dimensions (mm)

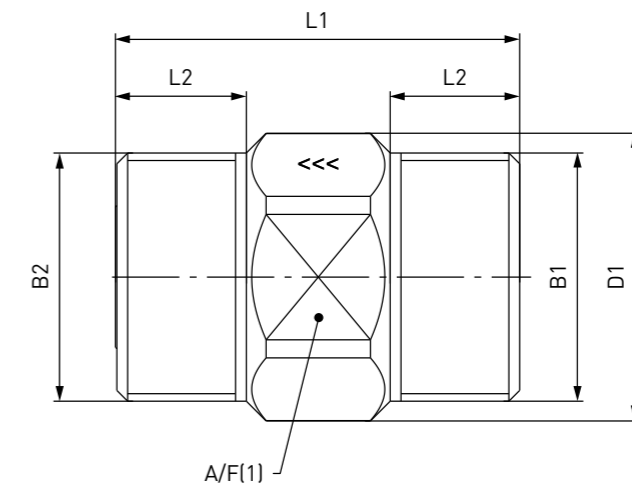

Part no.	Description	B1 (male thread)	B2 (male thread)	L1	L2	D1	A/F(1)
C1-77200-X01	TVR2	UNF 1 3/8"-12	UNF 1 3/8"-12	56	18	40	36

Other connection sizes and types on request.

Required information for ordering see page 7.

ACCESSORIES

The following accessories are available for the WEH® TVR2 Check valve:

Adaptors incl. sleeve nut

Adaptors with threaded or welded connection for installation of the TVR2 check valve (ports B1/B2) in pipelines or plants.

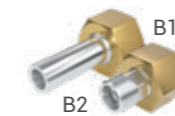

Part no.	Description	B1 (female thread)	B2
C1-164158	Adaptor	UNF 1 3/8"-12	M24x1.5* male thread for tube Ø 16
C1-166893	Adaptor	UNF 1 3/8"-12	Tube Ø 16**
C1-164157	Adaptor	UNF 1 3/8"-12	G3/8"
C1-100953***	Adaptor	UNF 1 3/8"-12	Tube Ø 16x2
C1-164156***	Adaptor	UNF 1 3/8"-12	Tube Ø 20x3

* 24° cone connection acc. to ISO 8434-1 (S16xM24)

** double ferrule fitting

*** with welding socket

» Filter TSF4

DESCRIPTION



Features

- Suitable for installation in gas mixing plants for the air and gas filtration
- Version for inert gases or oxygen
- Wear and corrosion resistant
- Easy replacement of filter element
- Simple installation
- High-quality materials

Clean, filtered gases are a basic requirement for the proper functioning of individual components when filling gases and using them in gas mixing plants. Seals in particular can be damaged by contaminants in the media flow, such as dirt particles. A special gas filter has been developed to clean the media flow from these components.

The WEH® TSF4 Filter is especially used in filling plants for oxygen and inert gases, such as argon and nitrogen. The filter removes the contaminants from the gas. The gas flows through the filter and the filter retains the dirt particles contained in the gas and in the piping system.

The TSF4 is suitable for high pressures and is particularly easy to maintain. The wire filter insert can be easily removed and cleaned without time-consuming unscrewing of pipes.

The WEH® TSF4 is equipped with a EPDM housing seal. Other sealing materials are available on request. It is the customer's responsibility to clarify the media compatibility.

Application

Filter for use with gaseous media and for installation in gas mixing plants.

TECHNICAL DATA

Characteristics	Basic version
Nominal bore (DN)	12 mm
Max. allowable operating pressure PS	420 bar
Temperature range	-20 °C up to +85 °C -10 °C up to +60 °C (O ₂)
Medium	Inert gases or oxygen
Material	Brass and stainless steel resp. Monel® (O ₂)
Sealing material	Housing seal of EPDM
Design	Incl. unscrewable filter element (40 µm)
Conformity / Tests / Approvals	Type approval for suitability against adiabatic compression available

Other designs on request

Example of use:



» Filter TSF4

ORDERING | WEH® TSF4 Filter

approx. dimensions (mm)

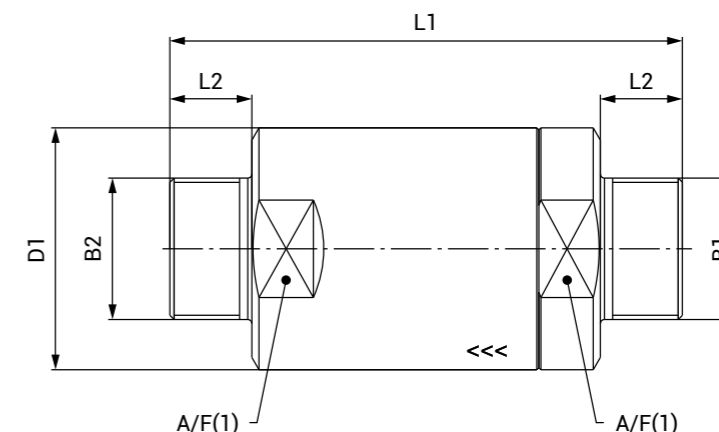

Part no.	Description	B1 (male thread)	B2 (male thread)	L1	L2	D1	A/F(1)
C1-82292-X01	TSF4	UNF 1 3/8"-12	UNF 1 3/8"-12	125	20	59	54
C1-92654-X01*	TSF4	UNF 1 3/8"-12	UNF 1 3/8"-12	125	20	59	54

* for oxygen

Other connection sizes and types on request. Required information for ordering see page 7.

ACCESSORIES

The following accessories are available for the WEH® TSF4 Filter:

Adaptors incl. sleeve nut

Adaptors with threaded or welded connection for installation of the TSF4 filter (ports B1/B2) in pipelines or plants.

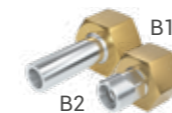

Part no.	Description	B1 (female thread)	B2
C1-164158	Adaptor	UNF 1 3/8"-12	M24x1.5* male thread for tube Ø 16
C1-166893	Adaptor	UNF 1 3/8"-12	Tube Ø 16**
C1-164157	Adaptor	UNF 1 3/8"-12	G3/8"
C1-100953***	Adaptor	UNF 1 3/8"-12	Tube Ø 16x2
C1-164156***	Adaptor	UNF 1 3/8"-12	Tube Ø 20x3

* 24° cone connection acc. to ISO 8434-1 (S16xM24)

** double ferrule fitting

*** with welding socket

SPARE PARTS

Various parts are available as spares for the WEH® TSF4 Filter.

Part no.	Description
W9062	Wire filter insert 40 µm
E69-91040*	Wire filter insert 40 µm

* Monel® construction for oxygen



» Pressure hose THP40

DESCRIPTION

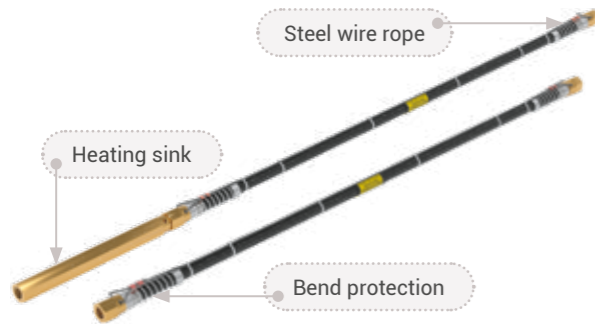

Features

- Version for oxygen and inert gases such as nitrogen, argon, CO₂, air, etc.
- Made of Kevlar® reinforced PTFE
- Bend protection (spiral) on both ends of the hose
- Steel wire rope to secure in case of unintentional loosening of hose connections

When filling gas cylinders with WEH® Connectors such as TW42, TW52, TW54, TW57, TW101, TW102 and TW152, the medium is often supplied to the connectors via hoses instead of pipes.

WEH® THP40 Hoses are made of Kevlar® reinforced PTFE and have a very high thermal degradation threshold and auto-ignition temperature due to their smooth bore finish. So even when the flow is at high pressure, there is only a low temperature rise. They are also resistant to a wide range of chemicals and solvents.

In addition, the pressure hoses offer excellent flexibility and bending tolerance, allowing the WEH® Connector used to be quickly and easily connected to the gas cylinder. Vibrations are absorbed, which reduces noise and protects mounting points such as fittings.

The pressure hoses can be used for various demanding applications.

With the THP40 pressure hoses, WEH offers a complete product range: from the quick connector for connection to the gas cylinder to the hose for installation on the gas filling plant.

Application

Pressure hose for connection of technical gas plants, such as gas filling plants, with WEH® Connectors.

TECHNICAL DATA

Characteristics	Basic version
Nominal bore (DN) pressure hose	6.35 mm (THP40-S1 / THP40-S3) 10.3 mm (THP40-S2 / THP40-S4)
Max. allowable operating pressure PS	420 bar
Temperature range	-30 °C up to +80 °C
Medium	Oxygen (THP40-S1 / THP40-S2) Inert gases as for example nitrogen, argon, CO ₂ , air etc. (THP40-S3 / THP40-S4)
Material	Hose: Kevlar® reinforced PTFE Fittings: brass
Sealing material	Acc. to gas type
Minimum bend radius	90 mm
Design	Complete with fittings, bend protection (spiral) at the press-fittings and steel wire rope to secure in case of unintentional loosening. Pressure hoses for oxygen are additionally equipped with a heat sink.
Conformity / Tests / Approvals	ISO 14113:2013

Other designs on request

» Pressure hose THP40

OVERVIEW PRODUCT SERIES

Product series	Medium		Nominal bore (DN)		Heat sink
	Oxygen	Inert gases	6.35 mm	10.3 mm	
THP40-S1	X		X		X
THP40-S2	X			X	X
THP40-S3		X	X		
THP40-S4		X		X	

ORDERING | WEH® THP40 - S1 Pressure hose

approx. dimensions (mm)

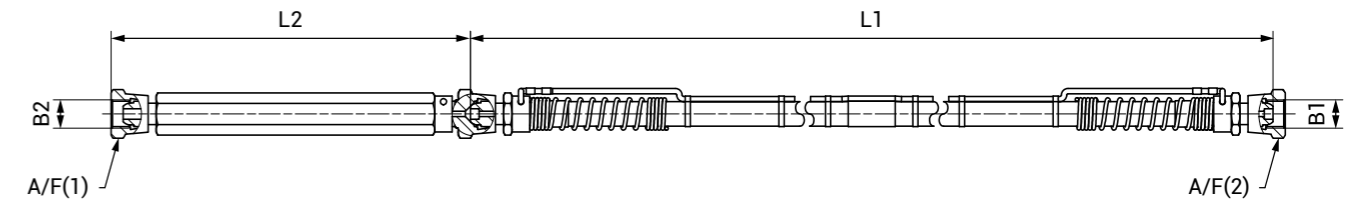

Part no.	Description	DN (mm)	Pressure (PS)	B1 (female thread)	B2 (female thread)	L1	L2	A/F(1) / A/F(2)
C1-176385	THP40 - S1	6.35	420 bar	M16x1.5	M16x1.5	1000	200	24
C1-176387	THP40 - S1	6.35	420 bar	M16x1.5	M16x1.5	1500	200	24
C1-176388	THP40 - S1	6.35	420 bar	M16x1.5	M16x1.5	2000	200	24
C1-176389	THP40 - S1	6.35	420 bar	NPT 1/4"	NPT 1/4"	1000	200	24
C1-176390	THP40 - S1	6.35	420 bar	NPT 1/4"	NPT 1/4"	1500	200	24
C1-176391	THP40 - S1	6.35	420 bar	NPT 1/4"	NPT 1/4"	2000	200	24

Other connection types and hose lengths on request.

On request the pressure hose for oxygen is also available with a nominal bore (DN) of 10.3 mm

➔ THP40-S2

» Pressure hose THP40

ORDERING | WEH® THP40 - S3 Pressure hose

approx. dimensions (mm)

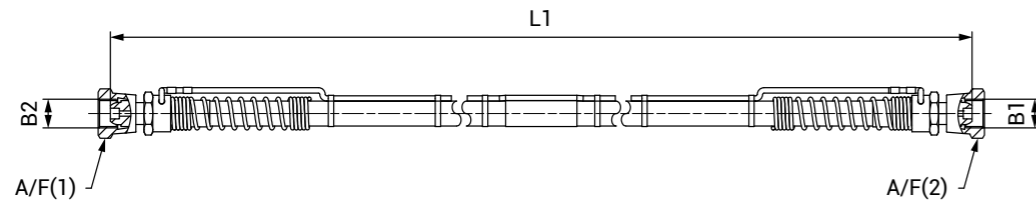

Part no.	Description	DN (mm)	Pressure (PS)	B1 (female thread)	B2 (female thread)	L1	A/F(1) / A/F(2)
C1-176398	THP40 - S3	6.35	420 bar	M16x1.5	M16x1.5	1000	24
C1-176400	THP40 - S3	6.35	420 bar	M16x1.5	M16x1.5	1500	24
C1-176401	THP40 - S3	6.35	420 bar	M16x1.5	M16x1.5	2000	24
C1-176402	THP40 - S3	6.35	420 bar	NPT 1/4"	NPT 1/4"	1000	24
C1-176403	THP40 - S3	6.35	420 bar	NPT 1/4"	NPT 1/4"	1500	24
C1-176404	THP40 - S3	6.35	420 bar	NPT 1/4"	NPT 1/4"	2000	24

Other connection types and hose lengths on request.

On request the pressure hose for inert gases is also available with a nominal bore (DN) of 10.3 mm
 ➔ THP40-S4

Required information for ordering see page 7.

» Pressure hose THP40

» Technical appendix

Definitions

Abbreviation	Definition	
Pressure specifications		
PN	Nominal pressure	Nominal pressure after temperature compensation at 15 °C (59 °F)
PS	Max. allowable operating pressure	Maximum allowable operating pressure acc. to Pressure Equipment Directive 2014/68/EU, Article 2 paragraph 8
PT	Hydrostatic test pressure	Hydrostatic test pressure acc. to Pressure Equipment Directive 2014/68/EU, Annex I no. 7.4
PP	Pilot pressure	Actuation pressure for hydraulic and pneumatic components
PC	Cracking pressure	Pressure at which the check valve opens and the first indication of flow occurs
WP	Working pressure	'Working pressure' means the maximum pressure to which a component is designed to be subjected to and which is the basis for determining the strength of the component under consideration
MAWP	Max. allowable working pressure	Max. allowable operating pressure at which the weakest point of the system or the vessel (e.g. cylinder valve) can operate at a certain temperature during normal operation
Dimensions		
L1, L2, L3 ...	Length specification	
D1, D2, D3 ...	Diameter specification	
A/F(1), A/F(2) ...	Wrench size specification	
Ports		
A / X	Customer-specific port (test piece, sample, cylinder valve, handwheel respiratory protective equipment)	
B1, B2, B3 ...	Media ports	
C1, C2, C3 ...	Gas recirculation ports	
P1, P2, P3 ...	Pilot pressure ports	
MA1, MA2 ...	Measuring ports	
Q	Drain port filter	
G	Mounting bores	
Others		
DN	Nominal size (DN) acc. to Pressure Equipment Directive 2014/68/EU, whereby the largest, pressurized diameter of the media or pilot pressure connections of the WEH® Device (A, B1, B2, B3 or C1, C2, C3 and P1, P2, P3) which faces the customer's pipe system, is relevant.	
µm	Max. diameter of the filtered particle	
Kv	Is the discharge of water in m³/h at a pressure drop of 1 bar (14.5 psi), acc. to DIN/EN 60534-2	
Cv	Is the discharge of water in gallons per minute at a pressure drop of 1 psi, acc. to DIN/EN 60534-2	
IR	Infrared data interface	
ENR	Exchangeable data interface (exchangeable nozzle receiver)	
TS	Maximum allowable temperature acc. to Pressure Equipment Directive 2014/68/EU, Article 2 paragraph 9	

» Technical appendix

Definitions

Abbreviation	Definition
Breakaway force	Is the force range, in which the breakaway releases
NC	Normally closed (initial position of shut-off valve)
NO	Normally open (initial position of shut-off valve)

Technical explanations

Term	Definition
Temperature range	Is the temperature range in which the WEH® Product can be used.
Media temperature range	Is the temperature range of the medium used, which can flow through the WEH® Product (may change depending on the time of measurement).
Ambient temperature range	Is the temperature range of the environment in which the WEH® Product can be used.
Leak rate	Is the maximum external leak rate, which the WEH® Product exhibits in delivery condition.
Internal leak rate	The internal leak rate depends, among other things, on type of application, medium and pressure difference on the WEH® Product. On request it can be specified more precisely.
Max. side load	Is the max. allowable sum of all external forces that may act on the device under intended use. Note: External forces can affect the life time of WEH® Products and can cause damage. Tensile and transverse loads as well as vibrations and pressure impacts need to be considered, e.g. by user side measures such as on site mountings and similar. Therefore, lateral forces such as whipping hoses or other equipment must be avoided. WEH® Products should be installed in such a way, that lateral forces which could lead to leakage or damage can not occur. Special applications require a special consultation before selecting the product.
Products with pneumatic actuation	The customer has to ensure there is adequate axial movement when pneumatically actuated WEH® Products are used in automated systems, see maximum side load. Ideally the products should be mounted with a floating joint or introduced individually to prevent the possibly existing clamping jaws getting blocked or jammed in the thread of the test piece.
Sealing material	On request the WEH® Product can be adapted to customer specific applications regarding to the sealing materials used. The clarification of the media compatibility and suitability of the adapted WEH® Product for the final application is always the responsibility of the end user.
Corrosion resistant	WEH® Products are designed for use in temperate climate zones - with low levels of humidity and salinity in the air. An accelerated formation of rust or corrosion may occur at or near the sea. Therefore, reduce the inspection interval recommended for normal use and send in the WEH® Product for maintenance immediately if you notice increased soot, rust or corrosion.
Storage / life time of components	There are certain requirements for every WEH® Product. WEH® Products are generally products which may be subject to wear and fatigue during operation and depending on your individual application/use. For details - in particular regarding the corresponding minimum inspection and maintenance intervals - please refer to the respective operating instructions for the WEH® Product.

» Technical appendix

Further explanations

Subject	Definition
Technical data	Unless otherwise stated, the technical data in catalogs, data sheets and operating instructions are based on tests with nitrogen that are in the development phase or at the end of development. Leakage data are based on measurements with helium.
Intended use	For the intended use of WEH® Products, please refer to the respective operating instructions. The following applications are generally excluded for WEH® H ₂ and CNG products, unless these are expressly permitted in the operating instructions: <ul style="list-style-type: none"> • aerospace applications, e.g. in aircrafts • shipping applications • applications offshore and in littoral areas • applications within defense and weapons technology
Safe product selection	Our WEH® Products are designed to be operated by qualified professional users (insofar as WEH® Products are also designed to be operated by other users in individual cases, this is explicitly stated in the corresponding operating instructions). Please note that WEH does not know your system and therefore - also due to the large number of different potential applications of WEH® Products - cannot perform tests on all potential types of application. You alone are responsible for the selection, configuration and suitability of WEH® Products, especially according to the requirements of your system. Before purchasing WEH® Products, please particularly ensure that our products are compatible with your intended use, your performance data, your material and fluids, your system concept and your system limits according to our product specifications. Please also consider your technical and legal requirements for operation, handling and maintenance. The quality and safety of WEH® Products is our highest priority. For this reason, WEH® Products may not be used outside the specifications in the relevant data sheets and product descriptions. If you are not sure whether the WEH® Product is suitable for your system and intended use, please contact us in advance. We also strongly recommend that you refrain from using third-party spare parts or a combination of WEH® Products with unsuitable third-party products. You alone are responsible for reviewing the suitability of third-party products. WEH® Products and WEH® Spare parts comply with our quality and safety standards.
Explanation on the Pressure Equipment Directive	In general, WEH® Products with a maximum allowable operating pressure of more than 0.5 bar (PS) fall within the scope of application of the Pressure Equipment Directive 2014/68/EU, are generally classified as pressure accessories in accordance with Article 2 (5) of the same and are considered to be similar to piping. These WEH® Products may not be used as safety accessories. Furthermore, it is pointed out, that these WEH® Products are designed and placed on the market in accordance with the requirements of Article 4 (3) of the Pressure Equipment Directive 2014/68/EU. For some products a different classification and/or categorisation is required or can be conducted on request. In these cases, if legally required, a conformity assessment procedure in accordance with Annex III of the Pressure Equipment Directive 2014/68/EU can and will also be conducted and the conformity can be declared by means of an EU Declaration of Conformity in accordance with Annex IV of the Pressure Equipment Directive 2014/68/EU. In these cases, the EU Declaration of Conformity is enclosed with the product.
External change management	WEH reserves the right to update, optimise and adjust its products continuously. This may result in corresponding changes of the product. Customers will be informed proactively or unsolicited by WEH only in individual cases about product updates, product optimisations and/or product adaptations that have been carried out. You are free to contact WEH at any time to request information about any product updates, product optimisations and/or product adjustments.

» Brochure data

This catalog was created diligently and on the basis of decades of experience.

All information/recommendations in this catalog are non-binding and are particularly subject to possible deviations or changes. For any binding information/recommendations, please refer to the verified information/recommendations in our individual orders. Particularly, due to the wide range of possible applications of WEH® Products and the unknown parameters and operating conditions linked to them, the accuracy and/or completeness of the information/recommendations in this catalog cannot be guaranteed with respect to certain individual cases. In doing so, we would like to refer once again to the information/recommendations provided in individual orders.

The application limits indicated in this catalog (e.g. for pressure, temperature, etc.) are generally theoretical values determined in a test environment. As the concrete operating conditions could differ, we cannot ensure that these values apply to a specific customer application. During the practical use, you should particularly consider that the mutual influence of operational parameters could result in changes of the maximum values. Especially, in case of any unusual operating conditions, please contact WEH before using any WEH® Products. We therefore strongly recommend that you also require any necessary binding information/recommendations to be included by us in the individual orders.

Furthermore, we point out that we cannot assume any warranty or accept any responsibility for printing errors, incomplete information or misinterpretations. Illustrations and/or images are particularly provided for illustrative purposes only and may differ in some details from the actual product. Moreover, dimensions and other technical details in this catalog are non-binding information and are provided for illustrative purposes only. The product's exact form and design result exclusively from the specific individual order. In particular, certain information/recommendations in the catalog only become integral part of the contract if they have been expressly contractually agreed.

Only the latest version of our catalog and other product related documents is valid and applicable. Please ensure that you always use the latest catalog's and documents' versions. Please feel free to contact WEH at any time and request the latest versions.

Our General Terms and Conditions and the Agreement on Protection of Know-How and Quality Assurance shall apply to deliveries and other services, unless expressly agreed otherwise.

In principle, we do not accept the General Terms and Conditions of our customers or third parties. Thank you for your understanding.

WEH Official Sales Partner

METALIKA KACIN | Slovenija

Address: KACIN JOŽICA s.p. METALIKA
Bedrih 27
SI-4226 ŽIRI

Office: Biro / Warehouse ŽIRI
Račeva 8
SI-4226 ŽIRI

Phone: (+386) 041 / 694 339
Email: info@metalika-kacin.com

METALIKA KACIN | Srbija

Address: METALIKA KACIN d.o.o.
Kir Janjina 2
RS-11253 SREMČICA

Phone: (+381) 011 / 25 21 756
Mobile: (+381) 062 / 311 768
Email: srbija@metalika-kacin.com

METALIKA KACIN | Hrvatska

Address: KACIN METALIKA d.o.o.
Radićeva 18
HR-51000 RIJEKA

Phone: (+385) 051 / 213 060
Mobile: (+385) 091 / 58 70 744
Email: hrvatska@metalika-kacin.com

Design and production

WEH GmbH Precision Connectors
Josef-Henle-Str. 1
89257 Illertissen / Germany

Phone: +49 7303 9609-0
E-Mail: sales@weh.com
Website: www.weh.com

More questions? – Great! Don't hesitate to contact our experts.