

**METALIKA**  
COMPONENTS FOR INDUSTRY **KACIN**



2023 | Brief Overview | Connection solutions in general

# WEH<sup>®</sup> Connectors

for pressure-tight connections in seconds  
to threads, tubes, beads, etc.

METALIKA KACIN

Slovenija

**(+386) 041 694 339**

**info@metalika-kacin.com**

Hrvatska

**(+385) 051 213 060**

**hrvatska@metalika-kacin.com**

Srbija

**(+381) 011 25 21 756**

**srbija@metalika-kacin.com**



**50 YEARS**  
Quality & Safety



[www.METALIKA-KACIN.com](http://www.METALIKA-KACIN.com)

WEH<sup>®</sup> - We Engineer Hightech

# WEH® Quick Connectors

for pressure and function testing, filling and plugging

WEH® Connectors have become the global standard for general industrial applications. Whereas in the past all supply lines on test benches required time and effort to screw on, today the innovative WEH® Connectors enable pressure-tight connections in seconds.

Female or male threads, beads or straight tubes: WEH offers a solution for almost every application where a connection is needed. Suitable testing and/or filling connectors are available for each type of connection.

## WEH® Connectors for female threads



## WEH® Connectors for male threads



## WEH® Universal Connectors for threads, tubes, beads, etc.



As a long standing partner to the international automotive, hydraulic and other manufacturing industries, our experts have developed advanced solutions to make production processes faster, cost effective and more efficient.

Connection solutions for hydraulic, pneumatic and fluid applications include testing of pressure vessels, fluid lines, hydraulic aggregates / hydraulic pumps / hydraulic blocks, pneumatic components, air engines, engine / engine blocks, cylinder blocks / cylinder heads, injector pumps, steering racks, cylinders and automotive components.

# Overview of WEH® Connectors

Many connection and application possibilities

Type	max. allowable operating pressure bar	Male thread	Female thread	Straight tubes	Bores	Swages / Flares	Beads	Collars	Barbs
- TW17	350		✓						
- TW19	350		✓						
- TW05	5 - 12		✓						
- TW03	345		✓						
- TW18	350	✓				✓	✓	✓	✓
- TW04	50	✓							
- TW800	50	✓				✓	✓	✓	✓
- TW850	630	✓				✓	✓	✓	✓
- TW130	350	✓*	✓*			✓	✓	✓	✓*
- TW141	100			✓					
- TW221	3			✓	✓	✓	✓	✓	✓
- TW230	70			✓	✓			✓	✓
- TW241	70			✓					
- TW01	9		✓	✓	✓	✓	✓	✓	✓
- TW02	35	On request		✓		✓	✓	✓	✓

\* The test piece profile must allow a firm grip!  
Automated versions are also possible for many types of connector. Please contact us!

## Your advantages

- 1 Connection in seconds  
WITHOUT hand-tightening
- 2 No time-consuming hand-tightening
- 3 Reduced connection time
- 4 Time and cost savings

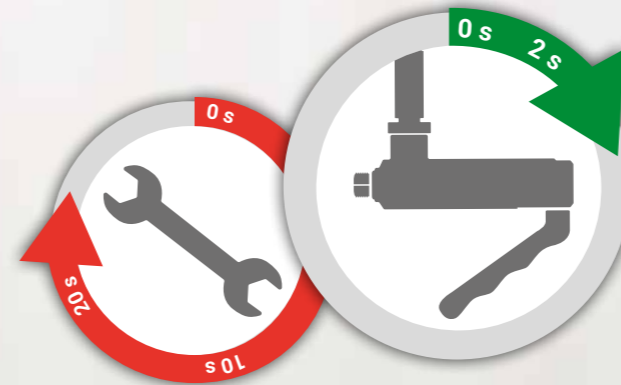

- 5 Increased productivity
- 6 Spares the operators' joints
- 7 Easy and comfortable operation



## The original WEH® Jaw locking mechanism

For a perfect connection in seconds

A major part of the connectors have the unique WEH® Jaw locking mechanism developed by WEH. Hard wearing jaws clamp securely and safely onto a large variety of different connections, including female and male threads, straight tubes, tube ends and bores among others. You do not need to attach a matching counterpiece to the component being checked. The connectors fit directly onto the test piece.

Laborious screwing and unscrewing of hoses is eliminated and the operators' joints are spared. The latest sealing technology provides a pressure-tight connection for your application. This means that additional Teflon strips or filler are not necessary.

The wear on the connecting piece is also minimised and deformations reduced through the low contact pressure compared with ball-type and screw-on connections.



# Markets

in which WEH has raised the bar

The development of the unique WEH® Jaw locking mechanism started the success of WEH® Connectors. When WEH introduced their very first invention, nobody knew that this incredibly simple, yet highly effective technology would write an entirely new chapter for the leak testing of components and would mean a giant leap forward in efficiency.

The very first WEH® TW05 connector was developed in 1980 and was filed for patent in 1983 – but it was only the first in a long line of quick connectors. The innovative quick connectors for

pressure, function and leak testing, as well as for the filling and evacuation of gaseous media created a pressure and function-tight connection in seconds.

Driven by a passion for precision and optimal economic viability, WEH developed an extensive product portfolio over the years.

Today, WEH® Product solutions are used in all key industry sectors:

- 1 General industrial applications
- 2 Automation technology
- 3 Automotive industry
- 4 Refrigeration and air conditioning industry
- 5 Gas industry
- 6 Breathing air

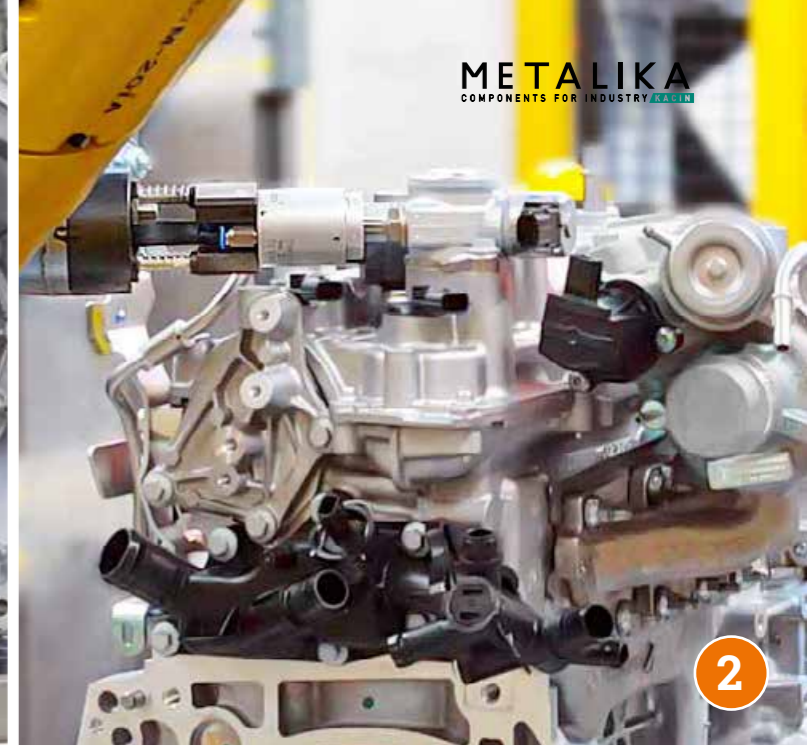

# Actuations

- 1 Manual actuation** with sliding sleeve
- 2 Pneumatic actuation** for external manual, semi or fully automatic control systems
- 3 Pneumatic actuation** via valve button
- 4 Manual actuation** via hand lever
- 5 Manual actuation** via clamping lever



## WEH® Quick Connectors

for female and male threads

### Connection in seconds with WEH® Connectors

It does not matter if you are dealing with female or male threads, WEH's test connectors ensure a pressure-tight connection in seconds, without the need for time-consuming tightening and loosening. Depending on the application, clamping jaws grip firmly into or onto the counterpiece, creating a secure connection.

To ensure that connector handling is as simple as possible and that connectors are suitable for a multitude of use cases, WEH® Connectors are available with the widest possible range of actuations, making them ideal for manual, pneumatic and fully automatic testing.

Connection solutions include testing of pressure vessels, fluid lines, hydraulic and pneumatic components, engines and many other automotive components.



Usability



Quality



Safety



Efficiency



Easy of  
maintenance



ECO  
friendliness

# WEH® Quick Connectors

for female and male thread



## WEH® TW17

Quick connector for pneumatic and hydraulic pressure and function testing of components with female thread, e.g. engines, cylinders, pressure vessels, hoses, fixtures, etc.

**Operating Pressure:**  
Vacuum up to max. 350 bar

**Actuations:**  
H = manual actuation via hand lever  
V = pneumatic actuation via valve button  
P = pneumatic actuation for external manual, semi or fully automatic control systems

**Connects to:**

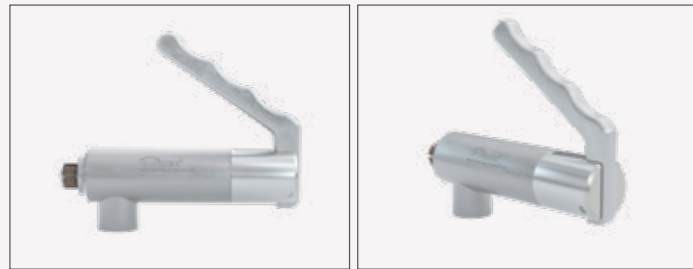

## WEH® TW18

Quick connector for pneumatic and hydraulic pressure and function testing of components with male thread, e.g. engines, cylinders, pressure vessels, hoses, fixtures, etc.

**Operating Pressure:**  
Vacuum up to max. 350 bar

**Actuations:**  
H = manual actuation via hand lever  
V = pneumatic actuation via valve button  
P = pneumatic actuation for external manual, semi or fully automatic control systems

**Connects to:**

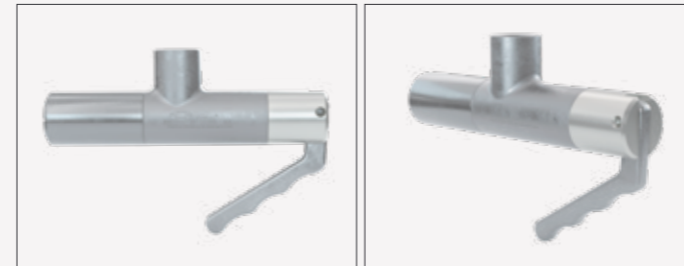

# WEH® Quick Connectors

for female and male thread

## WEH® TW05

Quick connector for pneumatic pressure and function testing of components with female thread, e.g. cylinders, valves, fixtures, pivot drives etc.

**Operating Pressure:**  
5 - 12 bar compressed air

**Actuation:**  
Manual actuation via sliding sleeve

**Connects to:**



## WEH® TW03

Quick connector for pressure and vacuum testing of components with female thread, e.g. fittings, fixtures, tubes, boilers, tanks, radiators, etc.

**Operating Pressure:**  
Vacuum up to max. 345 bar

**Actuation:**  
Hand-tightening

**Connects to:**



## WEH® TW19

Quick connector for pneumatic and oil-hydraulic pressure and function testing of components with female thread, e.g. hydraulic aggregates.

**Operating Pressure:**  
Vacuum up to max. 350 bar

**Actuation:**  
Manual actuation via clamping lever

**Connects to:**



## WEH® TW04

Quick connector for pressure and vacuum testing of components with male thread, e.g. fittings, fixtures, tubes, boilers, tanks, radiators, etc.

**Operating Pressure:**  
Vacuum up to max. 50 bar

**Actuation:**  
Hand-tightening

**Connects to:**

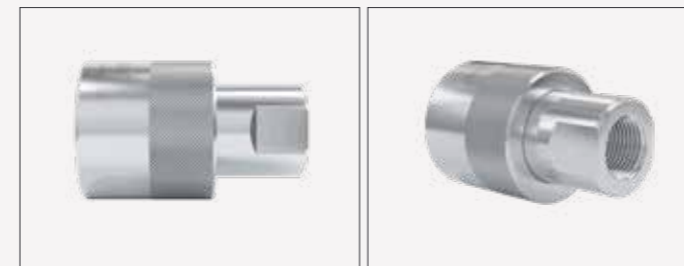



## WEH® Universal Connectors

for threads, tubes, beads, swages / flares, collars etc.

Aside from quick connectors for standardised threaded connections, we provide a multitude of universal connectors that can be connected using every imaginable connection configuration, including, for example,

**Hose connections using collars, beads or rims, straight tubes, bores, female or male grooves, flange connections, cartridge valves, and much more.**

WEH's universal quick connectors are the ideal tool for vacuum and helium testing, and for leakage, pressure and functional testing in the manufacturing industry, the automotive sector and with refrigeration and air conditioning technology.



- ▶ For tube Ø from 0.8 mm to 77.0 mm
- ▶ Wide range of tube tolerances up to  $\pm 0.25$  mm
- ▶ No seal adjustments required
- ▶ Large variety of connection possibilities



Usability



Quality



Safety



Efficiency



Easy of  
maintenance



ECO  
friendliness



# WEH® Universal Connectors

for threads, beads, tubes, etc.



## WEH® TW141

Quick connector for pressure and function testing of components with straight tube connection (sealing on external tube diameter), as for example leak testing of heat exchangers, air conditioning components and tube assemblies.

Filling of closed cooling circuits with refrigerants.

**Operating Pressure:**  
Vacuum up to max. 100 bar

**Actuation:**  
Manual actuation via hand lever

**Connects to:**



## WEH® TW241

Quick connector for pressure and vacuum testing of components with straight tube connection (sealing on external tube diameter) as for example heat exchangers, pressure vessels, valves, transducers, compressors, condensers, evaporation coils, tubing systems, air conditioners, heating systems etc.

**Operating Pressure:**  
Vacuum up to max. 70 bar

**Actuation:**  
Manual actuation via clamping lever

**Connects to:**

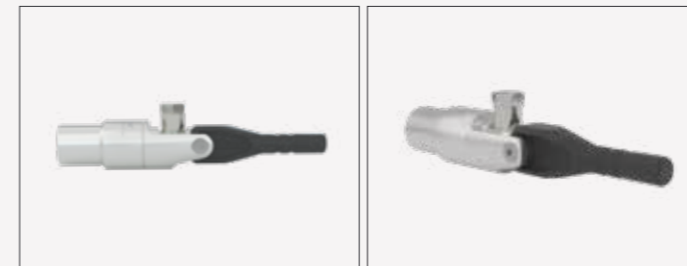

## WEH® TW221

Quick connector for pressure and vacuum testing of straight tubes and bores (sealing the internal tube diameter), as for example pressure vessels, valves, transducers, compressors, condensers, tubing systems etc.

**Operating Pressure:**  
Max. 3 bar

**Actuation:**  
Manual actuation via clamping lever

**Connects to:**



## WEH® TW230

Quick connector for pressure and vacuum testing of straight tubes and bores (sealing the internal tube diameter), as for example underwater, pressure decay and helium testing, heat exchangers, pressure vessels, valves, transducers, compressors, condensers, evaporation coils, component and tubing systems, air conditioners, heating systems etc.

**Operating Pressure:**  
Vacuum up to max. 70 bar

**Actuation:**  
Manual actuation via clamping lever

**Connects to:**

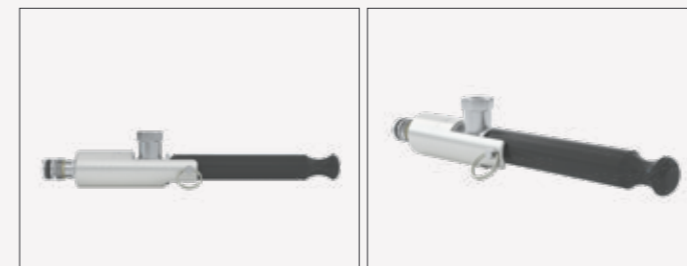

# WEH® Universal Connectors

for threads, beads, tubes, etc.



## WEH® TW800

Quick connector for pressure and function testing of components with bead, rim, collar, flange, stub or male thread, e.g. pressure vessels, compressors, heat exchangers, measuring devices, hoses, tubes, tanks, etc.

**Operating Pressure:**

Vacuum up to max. 50 bar

**Actuation:**

Manual actuation via sliding sleeve

**Connects to:**



## WEH® TW850

Quick connector for pressure and function testing of components with bead, rim, collar, flange, stub or male thread, e.g. pressure vessels, compressors, heat exchangers, measuring devices, hoses, tubes, tanks, etc.

**Operating Pressure:**

Vacuum up to max. 630 bar

**Actuation:**

Manual actuation via sliding sleeve

**Connects to:**



### WEH® TW800 | All-rounders

The TW800 test connector has proven itself as an all-round tool for the automotive industry. It is used, among other things, for the leak testing of fuel connectors, engines, compressors or for hot tests on the radiators of diesel engines and engine test stands.

But it has also proven itself as the ideal tool for refrigeration and air conditioning technology and in manufacturing.

# WEH® Universal Connectors

for threads, beads, tubes, etc.



## WEH® TW01

Quick connector for pressure and vacuum testing in straight tubes, in bores and on components with female thread. Leak testing: Pressure decay, underwater / helium tests.

Other applications: Filling, pressure and function tests, flushing, etc. Components: Vessels, plastic vessels, medical components, valves, pumps, filter, pressure vessels, tube connections, etc.

**Operating Pressure:**

Vacuum up to max. 9 bar

**Pilot pressure:**

Body size 01: 6 - 9 bar compressed air  
Body size 1 - 8: 6 - 12 bar compressed air

**Actuation:**

Pneumatic actuation

**Connects to:**

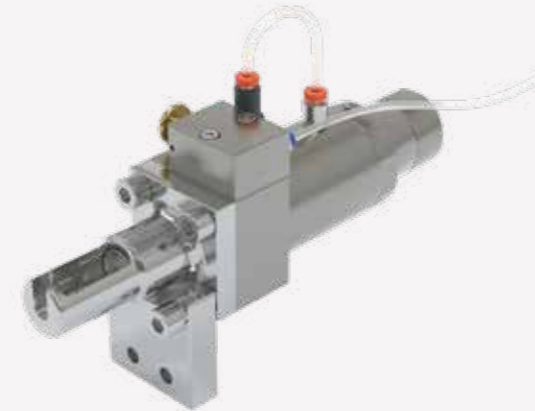

## WEH® TW130

Quick connector for pressure and function testing of components with banjo tube connections and hose / tube connections with sleeve nuts, e.g. for heat exchangers, high pressure hoses etc.

**Operating Pressure:**

Max. 350 bar

**Pilot pressure:**

6 - 8 bar

**Actuation:**

Pneumatic actuation via valve button

**Connects to:**

Banjo tube connections, hose / tube connections with sleeve nuts etc.

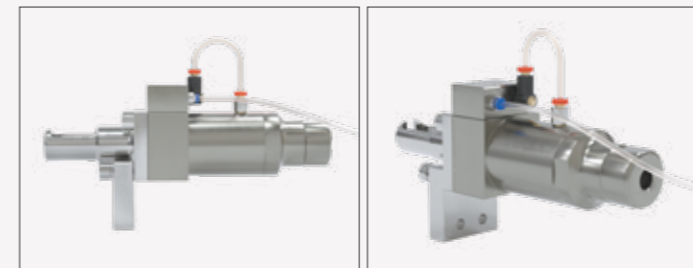

## WEH® TW02

Quick connector for pressure and vacuum testing of straight tubes, hoses and components with bead or collar. Special versions, e.g. twin connectors are available on request.

**Operating Pressure:**

Vacuum up to max. 35 bar

**Pilot pressure:**

6 - 12 bar compressed air

**Actuation:**

Pneumatic actuation

**Connects to:**

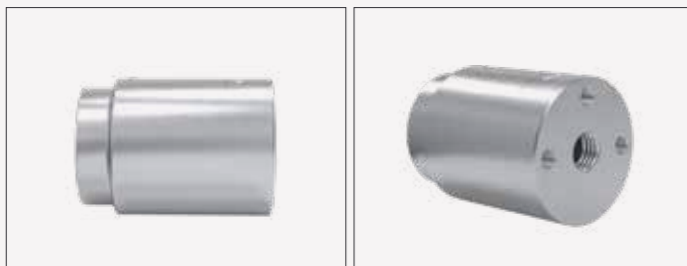

# Quality at WEH

- Made in Germany -

## Market proven technology for 50 years

WEH has long set the benchmark for quality. The innovative product range 'Made in Germany' is manufactured from high-grade material and meets with highest quality standards.

Customer satisfaction and operator safety are our top priority. Our commitment to high quality is firmly embedded in our corporate processes throughout the whole life cycle of our products - from design through manufacturing to service. Subjecting each product to the strictest quality and safety tests is for us a matter of course.

## The result of this philosophy?

Product solutions standing out for high quality and optimum safety providing numerous advantages:

- ▶ **Low down time**
- ▶ **Cost reduction and enhanced productivity**
- ▶ **Reliability and unique ease of operation**

## Certified quality management

Our quality standard is certified according to the highest requirements of recognised quality standards:

- ▶ **ISO 9001:2015**
- ▶ **Pressure Equipment Directive 2014/68/EU Annex III, Module H**

## Environmental Management at WEH

Environmentally responsible behaviour plays a significant part in our corporate philosophy. This applies to all business segments, whether for product development, manufacturing processes, logistics, administration or finances. We are striving for optimum use of resources for the manufacture of our products.

For 50 years, we have seen it as an obligation to develop and manufacture innovative products actively contributing to the protection of our environment.



## WEH® Customer Service

See for yourself!

In addition to their extensive range of products, WEH - a world specialist in connection technology - can also meet customer's special requirements with innovative solutions.

Wherever pressure-tight connections have to be established and testing procedures automated, we can supply the right solution for your application. Working in collaboration with our customers on demanding applications is our speciality.

Our portfolio of advanced connector solutions provides ample evidence of the innovative technology of WEH® Products. Find out for yourself!



## WEH Official Sales Partner

---

### METALIKA KACIN | Slovenija

KACIN JOŽICA s.p. METALIKA  
Bedrih 27  
SI-4226 ŽIRI

Biro / Warehouse ŽIRI  
Račeva 8  
SI-4226 ŽIRI

(+386) 041 / 694 339  
info@metalika-kacin.com

### METALIKA KACIN | Srbija

Address: METALIKA KACIN d.o.o.  
Kir Janjina 2  
RS-11253 SREMČICA

Phone: (+381) 011 / 25 21 756  
Mobile: (+381) 062 / 311 768  
Email: srbija@metalika-kacin.com

### METALIKA KACIN | Hrvatska

Address: KACIN METALIKA d.o.o.  
Radićeva 18  
HR-51000 RIJEKA

Phone: (+385) 051 / 213 060  
Mobile: (+385) 091 / 58 70 744  
Email: hrvatska@metalika-kacin.com

[www.METALIKA-KACIN.com](http://www.METALIKA-KACIN.com)

---

## Contact

More questions? - Great! Don't hesitate to contact our experts.

*Manufacturer:*

### WEH GmbH Verbindungstechnik

Josef-Henle-Str. 1  
89257 Illertissen / Germany

**Phone:** +49 7303 9609-0  
**E-Mail:** sales@weh.com  
**Website:** www.weh.com

© All rights reserved, WEH GmbH Verbindungstechnik. All rights reserved. No liability will be assumed for any content. Herewith previous versions are no longer valid.

Illustrations and / or images are particularly provided for illustrative purposes only and may differ in some details from the actual product. For binding information, please refer to your individual orders.

MD-10260-L01-R1.8.0-03