

DIN 172

Guide bushings
Drill bushings, with collar



page 1006

DIN 179

Guide bushings
Drill bushings, without collar



page 1008

GN 172.1

Guide bushings
with collar / with conical bore, for indexing plungers GN 817.5



page 1010

GN 179.1

Guide bushings
without collar / with conical bore, for indexing plungers GN 817.5



page 1010

GN 771.1

Guide pins



page 1011

GN 3490

Threaded flanges
for profile systems



page 1012

GN 6322

Workholding bolts
with ball-type shoulder



page 1013

GN 350

Levelling sets
Steel
long version



page 1014

GN 350-NI

Levelling sets
Stainless Steel
long version



page 1014

GN 350.1

Levelling sets
Steel



page 1016

GN 350.1-NI

Levelling sets
Stainless Steel



page 1016

GN 350.2

Levelling sets
Steel
with spherical washer,
without locknut



page 1018

GN 350.2-NI

Levelling sets
Stainless Steel
with spherical washer,
without locknut



page 1018

GN 350.5

Levelling sets
Steel
with spherical washer,
with locknut



page 1020

GN 350.5-NI

Levelling sets
Stainless Steel
with spherical washer,
with locknut



page 1020

GN 409.1

Positioning elements
with male thread



page 1022

GN 409.2

Positioning elements
with female thread



page 1023

DIN 6320

Feet



page 1024

GN 6321.1

Headed dowels



page 1024

DIN 6321

**Workholding bolts /
Headed dowels**



page 1025

Guide bushings

Drill bushings, with collar

SPECIFICATION

Type

- Type **A**: bore one-sided

Steel

hardened (HRC 62 ±2)

Fit sizes d₁, d₂ ground

INFORMATION

The dimensions listed in this standard sheet are merely a selection of the (currently withdrawn) DIN standards.

For applications involving positioning, we recommend the combination with the GN 771.1 guide pins (see page 1011).

For mounting bushings with tolerance n6, a hole with tolerance H7 corresponding to the external diameter is usually provided.

ON REQUEST

- other bores d_i

TECHNICAL INFORMATION

- ISO-Fundamental Tolerances (see page A21)

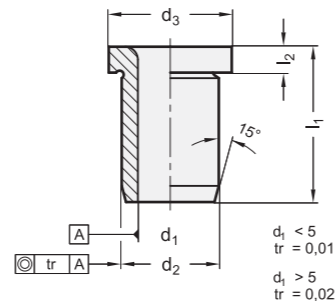

DIN 172

Description	d1 F7	l1	d2 n6	d3	l2	⚖
DIN 172-B2-6-A	B 2	6	5	8	2	1
DIN 172-B2-9-A	B 2	9	5	8	2	1
DIN 172-B2.1-6-A	B 2.1	6	5	8	2	1
DIN 172-B2.1-9-A	B 2.1	9	5	8	2	2
DIN 172-B2.5-6-A	B 2.5 (M 3)	6	5	8	2	1
DIN 172-B2.5-9-A	B 2.5 (M 3)	9	5	8	2	1
DIN 172-B3-8-A	B 3	8	6	9	2.5	2
DIN 172-B3-12-A	B 3	12	6	9	2.5	3
DIN 172-B3-16-A	B 3	16	6	9	2.5	3
DIN 172-B3.1-8-A	B 3.1	8	6	9	2.5	2
DIN 172-B3.1-12-A	B 3.1	12	6	9	2.5	3
DIN 172-B3.1-16-A	B 3.1	16	6	9	2.5	3
DIN 172-B3.3-8-A	B 3.3 (M 4)	8	6	9	2.5	2
DIN 172-B3.3-12-A	B 3.3 (M 4)	12	6	9	2.5	2
DIN 172-B3.3-16-A	B 3.3 (M 4)	16	6	9	2.5	4
DIN 172-B3.5-8-A	B 3.5	8	7	10	2.5	2
DIN 172-B3.5-12-A	B 3.5	12	7	10	2.5	3
DIN 172-B3.5-16-A	B 3.5	16	7	10	2.5	4
DIN 172-B3.8-8-A	B 3.8	8	7	10	2.5	4
DIN 172-B3.8-12-A	B 3.8	12	7	10	2.5	4
DIN 172-B3.8-16-A	B 3.8	16	7	10	2.5	5
DIN 172-B4-8-A	B 4	8	7	10	2.5	2
DIN 172-B4-12-A	B 4	12	7	10	2.5	3
DIN 172-B4-16-A	B 4	16	7	10	2.5	4
DIN 172-B4.1-8-A	B 4.1	8	8	11	2.5	3
DIN 172-B4.1-12-A	B 4.1	12	8	11	2.5	4
DIN 172-B4.1-16-A	B 4.1	16	8	11	2.5	6
DIN 172-B4.2-8-A	B 4.2 (M 5)	8	8	11	2.5	3
DIN 172-B4.2-12-A	B 4.2 (M 5)	12	8	11	2.5	4
DIN 172-B4.2-16-A	B 4.2 (M 5)	16	8	11	2.5	4

DIN 172

Description	d1 F7	l1	d2 n6	d3	l2	⚖
DIN 172-B4.5-8-A	B 4.5	8	8	11	2.5	3
DIN 172-B4.5-12-A	B 4.5	12	8	11	2.5	4
DIN 172-B4.5-16-A	B 4.5	16	8	11	2.5	4
DIN 172-B4.8-8-A	B 4.8	8	8	11	2.5	3
DIN 172-B4.8-12-A	B 4.8	12	8	11	2.5	4
DIN 172-B4.8-16-A	B 4.8	16	8	11	2.5	5
DIN 172-B5-8-A	B 5 (M 6)	8	8	11	2.5	2
DIN 172-B5-12-A	B 5 (M 6)	12	8	11	2.5	3
DIN 172-B5-16-A	B 5 (M 6)	16	8	11	2.5	4
DIN 172-B5.1-10-A	B 5.1	10	10	13	3	6
DIN 172-B5.1-16-A	B 5.1	16	10	13	3	8
DIN 172-B5.1-20-A	B 5.1	20	10	13	3	10
DIN 172-B5.5-10-A	B 5.5	10	10	13	3	5
DIN 172-B5.5-16-A	B 5.5	16	10	13	3	8
DIN 172-B5.5-20-A	B 5.5	20	10	13	3	10
DIN 172-B5.8-10-A	B 5.8	10	10	13	3	5
DIN 172-B5.8-16-A	B 5.8	16	10	13	3	8
DIN 172-B5.8-20-A	B 5.8	20	10	13	3	10
DIN 172-B6-10-A	B 6	10	10	13	3	5
DIN 172-B6-16-A	B 6	16	10	13	3	7
DIN 172-B6-20-A	B 6	20	10	13	3	9
DIN 172-B6.1-10-A	B 6.1	10	12	15	3	5
DIN 172-B6.1-16-A	B 6.1	16	12	15	3	12
DIN 172-B6.1-20-A	B 6.1	20	12	15	3	15
DIN 172-B6.5-10-A	B 6.5	10	12	15	3	7
DIN 172-B6.5-16-A	B 6.5	16	12	15	3	11
DIN 172-B6.5-20-A	B 6.5	20	12	15	3	14
DIN 172-B6.8-10-A	B 6.8 (M 8)	10	12	15	3	7
DIN 172-B6.8-16-A	B 6.8 (M 8)	16	12	15	3	11
DIN 172-B6.8-20-A	B 6.8 (M 8)	20	12	15	3	13

DIN 172

Description	d1 F7	l1	d2 n6	d3	l2	⚖
DIN 172-B7-10-A	B 7	10	12	15	3	7
DIN 172-B7-16-A	B 7	16	12	15	3	11
DIN 172-B7-20-A	B 7	20	12	15	3	12
DIN 172-B7.5-10-A	B 7.5	10	12	15	3	7
DIN 172-B7.5-16-A	B 7.5	16	12	15	3	11
DIN 172-B7.5-20-A	B 7.5	20	12	15	3	13
DIN 172-B7.8-10-A	B 7.8	10	12	15	3	6
DIN 172-B7.8-16-A	B 7.8	16	12	15	3	9
DIN 172-B7.8-20-A	B 7.8	20	12	15	3	12
DIN 172-B8-10-A	B 8	10	12	15	3	6
DIN 172-B8-16-A	B 8	16	12	15	3	9
DIN 172-B8-20-A	B 8	20	12	15	3	13
DIN 172-B8.1-12-A	B 8.1	12	15	18	3	13
DIN 172-B8.1-20-A	B 8.1	20	15	18	3	21
DIN 172-B8.1-25-A	B 8.1	25	15	18	3	26
DIN 172-B8.5-12-A	B 8.5 (M 10)	12	15	18	3	12
DIN 172-B8.5-20-A	B 8.5 (M 10)	20	15	18	3	20
DIN 172-B8.5-25-A	B 8.5 (M 10)	25	15	18	3	24
DIN 172-B9-12-A	B 9	12	15	18	3	12
DIN 172-B9-20-A	B 9	20	15	18	3	19
DIN 172-B9-25-A	B 9	25	15	18	3	24
DIN 172-B9.5-12-A	B 9.5	12	15	18	3	11
DIN 172-B9.5-20-A	B 9.5	20	15	18	3	18
DIN 172-B9.5-25-A	B 9.5	25	15	18	3	23
DIN 172-B9.8-12-A	B 9.8	12	15	18	3	11
DIN 172-B9.8-20-A	B 9.8	20	15	18	3	17
DIN 172-B9.8-25-A	B 9.8	25	15	18	3	22
DIN 172-B10-12-A	B 10	12	15	18	3	10
DIN 172-B10-20-A	B 10	20	15	18	3	17
DIN 172-B10-25-A	B 10	25	15	18	3	21
DIN 172-B10.1-12-A	B 10.1	12	18	22	4	20
DIN 172-B10.1-20-A	B 10.1	20	18	22	4	30
DIN 172-B10.1-25-A	B 10.1	25	18	22	4	35
DIN 172-B10.2-12-A	B 10.2 (M 12)	12	18	22	4	20
DIN 172-B10.2-20-A	B 10.2 (M 12)	20	18	22	4	30
DIN 172-B10.2-25-A	B 10.2 (M 12)	25	18	22	4	37
DIN 172-B10.5-12-A	B 10.5	12	18	22	4	19
DIN 172-B10.5-20-A	B 10.5	20	18	22	4	29
DIN 172-B10.5-25-A	B 10.5	25	18	22	4	36
DIN 172-B11-12-A	B 11	12	18	22	4	18
DIN 172-B11-20-A	B 11	20	18	22	4	28
DIN 172-B11-25-A	B 11	25	18	22	4	35
DIN 172-B11.5-12-A	B 11.5	12	18	22	4	17
DIN 172-B11.5-20-A	B 11.5	20	18	22	4	28
DIN 172-B11.5-25-A	B 11.5	25	18	22	4	33
DIN 172-B11.8-12-A	B 11.8	12	18	22	4	17
DIN 172-B11.8-20-A	B 11.8	20	18	22	4	26
DIN 172-B11.8-25-A	B 11.8	25	18	22	4	32
DIN 172-B12-12-A	B 12	12	18	22	4	16
DIN 172-B12-20-A	B 12	20	18	22	4	25
DIN 172-B12-25-A	B 12	25	18	22	4	31
DIN 172-B12.1-16-A	B 12.1	16	22	26	4	37
DIN 172-B12.1-28-A	B 12.1	28	22	26	4	62
DIN 172-B12.1-36-A	B 12.1	36	22	26	4	97
DIN 172-B12.5-16-A	B 12.5	16	22	26	4	36
DIN 172-B12.5-28-A	B 12.5	28	22	26	4	60
DIN 172-B12.5-36-A	B 12.5	36	22	26	4	78
DIN 172-B13-16-A	B 13 (M 14)	16	22	26	4	35
DIN 172-B13-28-A	B 13 (M 14)	28	22	26	4	58

DIN 172

Description	d1 F7	l1	d2 n6	d3	l2	⚖
DIN 172-B13-36-A	B 13 (M 14)	36	22	26	4	74
DIN 172-B13.5-16-A	B 13.5	16	22	26	4	33
DIN 172-B13.5-28-A	B 13.5	28	22	26	4	55
DIN 172-B13.5-36-A	B 13.5	36	22	26	4	71
DIN 172-B14-16-A	B 14 (M 16)	16	22	26	4	32
DIN 172-B14-28-A	B 14 (M 16)	28	22	26	4	53
DIN 172-B14-36-A	B 14 (M 16)	36	22	26	4	68
DIN 172-B14.1-16-A	B 14.1	16	22	26	4	32
DIN 172-B14.1-28-A	B 14.1	28	22	26	4	53
DIN 172-B14.1-36-A	B 14.1	36	22	26	4	68
DIN 172-B14.5-16-A	B 14.5	16	22	26	4	31
DIN 172-B14.5-28-A	B 14.5	28	22	26	4	51
DIN 172-B14.5-36-A	B 14.5	36	22	26	4	65
DIN 172-B15-16-A	B 15	16	22	26	4	29
DIN 172-B15-28-A	B 15	28	22	26	4	48
DIN 172-B15-36-A	B 15	36	22	26	4	61
DIN 172-B15.5-16-A	B 15.5	16	26	30	4	47
DIN 172-B15.5-28-A	B 15.5	28	26	30	4	79
DIN 172-B15.5-36-A	B 15.5	36	26	30	4	80
DIN 172-B16-16-A	B 16	16	26	30	4	46
DIN 172-B16-28-A	B 16	28	26	30	4	76
DIN 172-B16-36-A	B 16	36	26	30	4	98
DIN 172-B16.1-16-A	B 16.1	16	26	30	4	45
DIN 172-B16.1-28-A	B 16.1	28	26	30	4	75
DIN 172-B16.1-36-A	B 16.1	36	26	30	4	97
DIN 172-B16.5-16-A	B 16.5	16	26	30	4	44
DIN 172-B16.5-28-A	B 16.5	28	26	30	4	74
DIN 172-B16.5-36-A	B 16.5	36	26	30	4	95
DIN 172-B17-16-A	B 17	16	26	30	4	42
DIN 172-B17-28-A	B 17	28	26	30	4	71
DIN 172-B17-36-A	B 17	36	26	30	4	91
DIN 172-B18-16-A	B 18	16	26	30	4	39
DIN 172-B18-28-A	B 18	28	26	30	4	64
DIN 172-B18-36-A	B 18	36	26	30	4	83
DIN 172-B19-20-A	B 19	20	30	34	5	80
DIN 172-B19-36-A	B 19	36	30	34	5	124
DIN 172-B19-45-A	B 19	45	30	34	5	155
DIN 172-B20-20-A	B 20	20	30	34	5	100
DIN 172-B20-36-A	B 20					

Guide bushings

Drill bushings, without collar

SPECIFICATION

Type

- Type **A**: bore one-sided

Steel

hardened (HRC 62 ±2)

Fit sizes d₁, d₂ ground

INFORMATION

The dimensions listed in this standard sheet are merely a selection of the (currently withdrawn) DIN standards.

For applications involving positioning, we recommend the combination with the GN 771.1 (see page 1011) guide pins.

For mounting bushings with tolerance n6, a hole with tolerance H7 corresponding to the external diameter is usually provided.

ON REQUEST

- other bores d₁

TECHNICAL INFORMATION

- ISO-Fundamental Tolerances (see page A21)

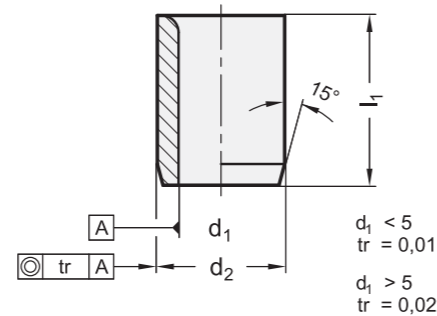

DIN 179

Description	d1 F7	l1	d2 n6	d3	l2	△
DIN 179-B2-6-A	B 2	6	5	8	2	1
DIN 179-B2-9-A	B 2	9	5	8	2	1
DIN 179-B2.1-6-A	B 2.1	6	5	8	2	1
DIN 179-B2.1-9-A	B 2.1	9	5	8	2	1
DIN 179-B2.5-6-A	B 2.5 (M 3)	6	5	8	2	1
DIN 179-B2.5-9-A	B 2.5 (M 3)	9	5	8	2	1
DIN 179-B3-8-A	B 3	8	6	9	2.5	1
DIN 179-B3-12-A	B 3	12	6	9	2.5	2
DIN 179-B3-16-A	B 3	16	6	9	2.5	3
DIN 179-B3.1-8-A	B 3.1	8	6	9	2.5	1
DIN 179-B3.1-12-A	B 3.1	12	6	9	2.5	2
DIN 179-B3.1-16-A	B 3.1	16	6	9	2.5	4
DIN 179-B3.3-8-A	B 3.3 (M 4)	8	6	9	2.5	1
DIN 179-B3.3-12-A	B 3.3 (M 4)	12	6	9	2.5	2
DIN 179-B3.3-16-A	B 3.3 (M 4)	16	6	9	2.5	4
DIN 179-B3.5-8-A	B 3.5	8	7	10	2.5	2
DIN 179-B3.5-12-A	B 3.5	12	7	10	2.5	3
DIN 179-B3.5-16-A	B 3.5	16	7	10	2.5	4
DIN 179-B3.8-8-A	B 3.8	8	7	10	2.5	2
DIN 179-B3.8-12-A	B 3.8	12	7	10	2.5	3
DIN 179-B3.8-16-A	B 3.8	16	7	10	2.5	4
DIN 179-B4-8-A	B 4	8	7	10	2.5	2
DIN 179-B4-12-A	B 4	12	7	10	2.5	2
DIN 179-B4-16-A	B 4	16	7	10	2.5	3
DIN 179-B4.1-8-A	B 4.1	8	8	11	2.5	2
DIN 179-B4.1-12-A	B 4.1	12	8	11	2.5	3
DIN 179-B4.1-16-A	B 4.1	16	8	11	2.5	5
DIN 179-B4.2-8-A	B 4.2 (M 5)	8	8	11	2.5	2
DIN 179-B4.2-12-A	B 4.2 (M 5)	12	8	11	2.5	3
DIN 179-B4.2-16-A	B 4.2 (M 5)	16	8	11	2.5	4

DIN 179

Description	d1 F7	l1	d2 n6	d3	l2	△
DIN 179-B4.5-8-A	B 4.5	8	8	11	2.5	2
DIN 179-B4.5-12-A	B 4.5	12	8	11	2.5	3
DIN 179-B4.5-16-A	B 4.5	16	8	11	2.5	5
DIN 179-B4.8-8-A	B 4.8	8	8	11	2.5	2
DIN 179-B4.8-12-A	B 4.8	12	8	11	2.5	3
DIN 179-B4.8-16-A	B 4.8	16	8	11	2.5	3
DIN 179-B5-8-A	B 5 (M 6)	8	8	11	2.5	2
DIN 179-B5-12-A	B 5 (M 6)	12	8	11	2.5	3
DIN 179-B5-16-A	B 5 (M 6)	16	8	11	2.5	4
DIN 179-B5.1-10-A	B 5.1	10	10	13	3	4
DIN 179-B5.1-16-A	B 5.1	16	10	13	3	4
DIN 179-B5.1-20-A	B 5.1	20	10	13	3	9
DIN 179-B5.5-10-A	B 5.5	10	10	13	3	4
DIN 179-B5.5-16-A	B 5.5	16	10	13	3	7
DIN 179-B5.5-20-A	B 5.5	20	10	13	3	9
DIN 179-B5.8-10-A	B 5.8	10	10	13	3	4
DIN 179-B5.8-16-A	B 5.8	16	10	13	3	6
DIN 179-B5.8-20-A	B 5.8	20	10	13	3	9
DIN 179-B6-10-A	B 6	10	10	13	3	4
DIN 179-B6-16-A	B 6	16	10	13	3	6
DIN 179-B6-20-A	B 6	20	10	13	3	8
DIN 179-B6.1-10-A	B 6.1	10	12	15	3	6
DIN 179-B6.1-16-A	B 6.1	16	12	15	3	10
DIN 179-B6.1-20-A	B 6.1	20	12	15	3	20
DIN 179-B6.5-10-A	B 6.5	10	12	15	3	6
DIN 179-B6.5-16-A	B 6.5	16	12	15	3	10
DIN 179-B6.5-20-A	B 6.5	20	12	15	3	20
DIN 179-B6.8-10-A	B 6.8 (M 8)	10	12	15	3	6
DIN 179-B6.8-16-A	B 6.8 (M 8)	16	12	15	3	9
DIN 179-B6.8-20-A	B 6.8 (M 8)	20	12	15	3	20

DIN 179

Description	d1 F7	l1	d2 n6	d3	l2	△
DIN 179-B7-10-A	B 7	10	12	15	3	6
DIN 179-B7-16-A	B 7	16	12	15	3	9
DIN 179-B7-20-A	B 7	20	12	15	3	12
DIN 179-B7.5-10-A	B 7.5	10	12	15	3	5
DIN 179-B7.5-16-A	B 7.5	16	12	15	3	8
DIN 179-B7.5-20-A	B 7.5	20	12	15	3	20
DIN 179-B7.8-10-A	B 7.8	10	12	15	3	5
DIN 179-B7.8-16-A	B 7.8	16	12	15	3	8
DIN 179-B7.8-20-A	B 7.8	20	12	15	3	20
DIN 179-B8-10-A	B 8	10	12	15	3	5
DIN 179-B8-16-A	B 8	16	12	15	3	11
DIN 179-B8-20-A	B 8	20	12	15	3	10
DIN 179-B8.1-12-A	B 8.1	12	15	18	3	12
DIN 179-B8.1-20-A	B 8.1	20	15	18	3	19
DIN 179-B8.1-25-A	B 8.1	25	15	18	3	20
DIN 179-B8.5-12-A	B 8.5 (M 10)	12	15	18	3	11
DIN 179-B8.5-20-A	B 8.5 (M 10)	20	15	18	3	18
DIN 179-B8.5-25-A	B 8.5 (M 10)	25	15	18	3	20
DIN 179-B9-12-A	B 9	12	15	18	3	10
DIN 179-B9-20-A	B 9	20	15	18	3	17
DIN 179-B9-25-A	B 9	25	15	18	3	20
DIN 179-B9.5-12-A	B 9.5	12	15	18	3	10
DIN 179-B9.5-20-A	B 9.5	20	15	18	3	16
DIN 179-B9.5-25-A	B 9.5	25	15	18	3	21
DIN 179-B9.8-12-A	B 9.8	12	15	18	3	9
DIN 179-B9.8-20-A	B 9.8	20	15	18	3	15
DIN 179-B9.8-25-A	B 9.8	25	15	18	3	20
DIN 179-B10-12-A	B 10	12	15	18	3	9
DIN 179-B10-20-A	B 10	20	15	18	3	15
DIN 179-B10-25-A	B 10	25	15	18	3	19
DIN 179-B10.1-12-A	B 10.1	12	18	22	4	14
DIN 179-B10.1-20-A	B 10.1	20	18	22	4	17
DIN 179-B10.1-25-A	B 10.1	25	18	22	4	20
DIN 179-B10.2-12-A	B 10.2 (M 12)	12	18	22	4	16
DIN 179-B10.2-20-A	B 10.2 (M 12)	20	18	22	4	20
DIN 179-B10.2-25-A	B 10.2 (M 12)	25	18	22	4	22
DIN 179-B10.5-12-A	B 10.5	12	18	22	4	15
DIN 179-B10.5-20-A	B 10.5	20	18	22	4	15
DIN 179-B10.5-25-A	B 10.5	25	18	22	4	20
DIN 179-B11-12-A	B 11	12	18	22	4	15
DIN 179-B11-20-A	B 11	20	18	22	4	24
DIN 179-B11-25-A	B 11	25	18	22	4	31
DIN 179-B11.5-12-A	B 11.5	12	18	22	4	14
DIN 179-B11.5-20-A	B 11.5	20	18	22	4	25
DIN 179-B11.5-25-A	B 11.5	25	18	22	4	30
DIN 179-B11.8-12-A	B 11.8	12	18	22	4	13
DIN 179-B11.8-20-A	B 11.8	20	18	22	4	22
DIN 179-B11.8-25-A	B 11.8	25	18	22	4	29
DIN 179-B12-12-A	B 12	12	18	22	4	13
DIN 179-B12-20-A	B 12	20	18	22	4	22
DIN 179-B12-25-A	B 12	25	18	22	4	29
DIN 179-B12.1-16-A	B 12.1	16	22	26	4	33
DIN 179-B12.1-28-A	B 12.1	28	22	26	4	57
DIN 179-B12.1-36-A	B 12.1	36	22	26	4	75
DIN 179-B12.5-16-A	B 12.5	16	22	26	4	32
DIN 179-B12.5-28-A	B 12.5	28	22	26	4	56
DIN 179-B12.5-36-A	B 12.5	36	22	26	4	73
DIN 179-B13-16-A	B 13 (M 14)	16	22	26	4	30
DIN 179-B13-28-A	B 13 (M 14)	28	22	26	4	53

DIN 179

Description	d1 F7	l1	d2 n6	d3	l2	△
DIN 179-B13-36-A	B 13 (M 14)	36	22	26	4	70
DIN 179-B13.5-16-A	B 13.5	16	22	26	4	29
DIN 179-B13.5-28-A	B 13.5	28	22	26	4	51
DIN 179-B13.5-36-A	B 13.5	36	22	26	4	67
DIN 179-B14-16-A	B 14 (M 16)	16	22	26	4	28
DIN 179-B14-28-A	B 14 (M 16)	28	22	26	4	49
DIN 179-B14-36-A	B 14 (M 16)	36	22	26	4	64
DIN 179-B14.1-16-A	B 14.1	16	22	26	4	28
DIN 179-B14.1-28-A	B 14.1	28	22	26	4	48
DIN 179-B14.1-36-A	B 14.1	36	22	26	4	61
DIN 179-B14.5-16-A	B 14.5	16	22	26	4	26
DIN 179-B14.5-28-A	B 14.5	28	22	26	4	46
DIN 179-B14.5-36-A	B 14.5	36	22	26	4	59
DIN 179-B15-16-A	B 15	16	22	26	4	25
DIN 179-B15-28-A	B 15	28	22	26	4	44
DIN 179-B15-36-A	B 15	36	22	26	4	58
DIN 179-B15.5-16-A	B 15.5	16	26	30	4	42
DIN 179-B15.5-28-A	B 15.5	28	26	30	4	74
DIN 179-B15.5-36-A	B 15.5	36	26	30	4	97
DIN 179-B16-16-A	B 16	16	26	30	4	40
DIN 179-B16-28-A	B 16	28	26	30	4	72
DIN 179-B16-36-A	B 16	36	26	30	4	93
DIN 179-B16.1-16-A	B 16.1	16	26	30	4	40
DIN 179-B16.1-28-A	B 16.1	28	26	30	4	71
DIN 179-B16.1-36-A	B 16.1	36	26	30	4	82
DIN 179-B16.5-16-A	B 16.5	16	26	30	4	39
DIN 179-B16.5-28-A	B 16.5	28	26	30	4	69
DIN 179-B16.5-36-A	B 16.5	36	26	30	4	89
DIN 179-B17-16-A	B 17	16	26	30	4	37
DIN 179-B17-28-A	B 17	28	26	30	4	66
DIN 179-B17-36-A	B 17	36	26	30	4	86
DIN 179-B18-16-A	B 18	16	26	30	4	34
DIN 179-B18-28-A	B 18	28	26	30	4	60
DIN 179-B18-36-A	B 18	36	26	30	4	78
DIN 179-B19-20-A	B 19	20	30	34	5	65
DIN 179-B19-36-A	B 19	36	30	34	5	117
DIN 179-B19-45-A	B 19	45	30	34	5	148
DIN 179-B20-20-A	B 20	20	30	34	5	60
DIN 179-B20-36-A	B 20					



Guide bushings

with collar / with conical bore, for indexing plungers GN 817.5

SPECIFICATION

Steel
hardened (HRC 60 ±2)

INFORMATION

Guide bushings GN 172.1 with conical bore will be used for the latch bore of indexing plungers GN 817.5 (see page 796).

TECHNICAL INFORMATION

- ISO-Fundamental Tolerances (see page A21)

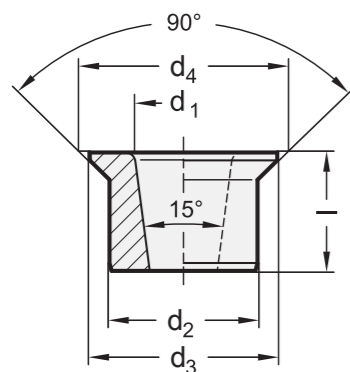

GN 172.1

Description	d1	d2 n6	d3	d4	l	ΔΔ
GN 172.1-6-10	6	10	12.5	13.5	8	4
GN 172.1-8-12	8	12	15	16	10	6
GN 172.1-10-15	10	15	19	20.6	12	12

Guide bushings

without collar / with conical bore, for indexing plungers GN 817.5

SPECIFICATION

Steel
hardened (HRC 60 ±2)

INFORMATION

Guide bushings GN 179.1 with conical bore will be used for the latch bore of indexing plungers GN 817.5 (see page 796).

TECHNICAL INFORMATION

- ISO-Fundamental Tolerances (see page A21)

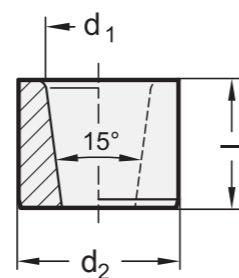

GN 179.1

Description	d1	d2 n6	l	ΔΔ
GN 179.1-6-10	6	10	8	4
GN 179.1-8-12	8	12	10	7
GN 179.1-10-15	10	15	12	12

Guide pins

SPECIFICATION

Steel
- hardened (HRC 60 ±2)
- Fit sizes d p6 / d h6 ground

INFORMATION

Guide pins GN 771.1 are normally used in combination with DIN 172 (see page 1006) / DIN 179 (see page 1008) guide bushings. The shaft tolerance p6 guarantees a perfect pressfit in a mounting borehole H7. The spigot l3 makes the installation easier.

TECHNICAL INFORMATION

- ISO-Fundamental Tolerances (see page A21)

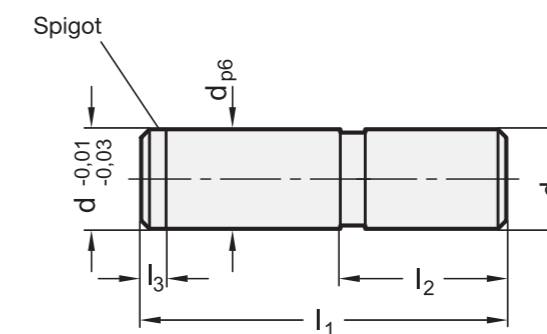

GN 771.1

Description	d p6/h6	l1	l2	l3	ΔΔ
GN 771.1-4-16-8	4	16	8	1.5	2
GN 771.1-5-18-8	5	18	8	1.5	3
GN 771.1-6-22-10	6	22	10	1.5	10
GN 771.1-8-24-10	8	24	10	2	11
GN 771.1-10-28-12	10	28	12	2	20
GN 771.1-12-30-12	12	30	12	2.5	26
GN 771.1-16-36-16	16	36	16	2.5	59

Threaded flanges

for profile systems

SPECIFICATION

Steel fine casting

- zinc plated, blue passivated **ZB**
- zinc plated and plastic coated black, RAL 9005, textured finish **SW**

INFORMATION

Threaded flanges GN 3490 are used in connection with T-slot profile systems and allow elements to be assembled on or underneath the profiles, e.g. levelling feet.

Depending on the threaded flange, thread size and thread depth dimensions that are available can exceed the dimensions of the profile groove.

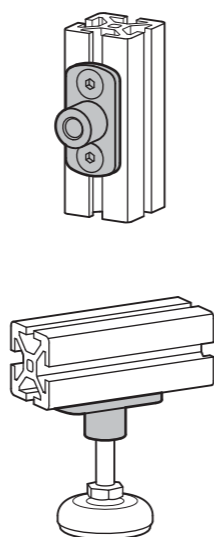
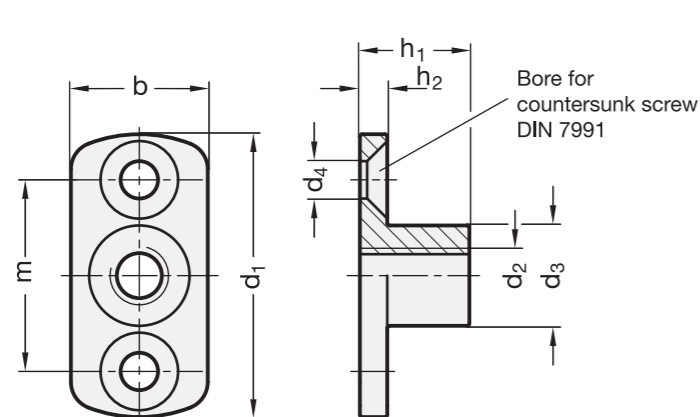

GN 3490

Description	d1	d2	h1	b	d3	d4	h2	m	⚖
GN 3490-45-M6-16-SW	45	M 6	16	25	15	M 6	6	30	51
GN 3490-45-M6-16-ZB	45	M 6	16	25	15	M 6	6	30	51
GN 3490-45-M8-16-SW	45	M 8	16	25	15	M 6	6	30	108
GN 3490-45-M8-16-ZB	45	M 8	16	25	15	M 6	6	30	108
GN 3490-60-M10-24-SW	60	M 10	24	30	21.5	M 8	6	40	103
GN 3490-60-M10-24-ZB	60	M 10	24	30	21.5	M 8	6	40	103
GN 3490-60-M12-24-SW	60	M 12	24	30	21.5	M 8	6	40	103
GN 3490-60-M12-24-ZB	60	M 12	24	30	21.5	M 8	6	40	103

Workholding bolts

with ball-type shoulder

SPECIFICATION

Types

- Type **B**: Workholding bolt cylindrical
- Type **C**: Workholding bolt flattened

Steel
hardened

INFORMATION

Workholding bolts GN 6322 are used for positioning in bores, with the ball-type shoulder facilitating the insertion into the bore.

The flattened design (Form C) helps to compensate tolerances in the spacing of two bores. Another application of this design is to fix parts to be positioned in one direction only.



TECHNICAL INFORMATION

- ISO-Fundamental Tolerances (see page A21)

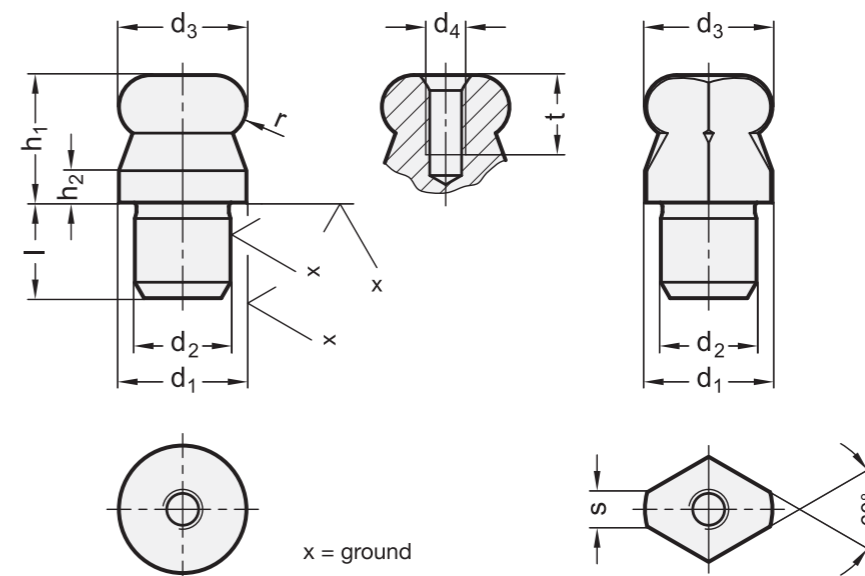

Application example

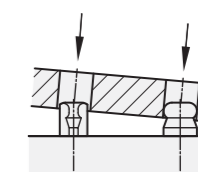

GN 6322

Description	d1 g6	d2 n6	d3 -0.01/-0.05	d4	h1	h2	l	s	t	r	⚖
GN 6322-10-7-B	10	7	10	M 3	10	2.5	7	-	6	2.5	7
GN 6322-12-8-B	12	8	12	M 4	12	3	8	-	8	3	11
GN 6322-16-12-B	16	12	16	M 5	16	4	12	-	10	4	30
GN 6322-20-14-B	20	14	20	M 5	20	5	14	-	10	5	57
GN 6322-22-16-B	22	16	22	M 5	22	5.5	16	-	10	5.5	79
GN 6322-25-18-B	25	18	25	M 5	25	6	18	-	10	6	116
GN 6322-10-7-C	10	7	10	M 3	10	2.5	7	2.5	6	2.5	5
GN 6322-12-8-C	12	8	12	M 4	12	3	8	2.5	8	3	8
GN 6322-16-12-C	16	12	16	M 5	16	4	12	4.3	10	4	24
GN 6322-20-14-C	20	14	20	M 5	20	5	14	5	10	5	45
GN 6322-22-16-C	22	16	22	M 5	22	5.5	16	5	10	5.5	62
GN 6322-25-18-C	25	18	25	M 5	25	6	18	5.6	10	6	90

Levelling sets

Steel / Stainless Steel, long version

SPECIFICATION

Types

- Type **A**: without lock nut
- Type **AK**: with lock nut

Version in Steel

Steel, 1.7225 (42 CrMo 4V) **ST**
zinc plated, blue passivated

Version in Stainless Steel

Stainless Steel AISI 303
(X 10 CrNiS 18-9) **NI**

F1: max. total load

F2: max. load after deduction of the max. preload

- for screws $8.8 \mu = 0.125$ (Steel version)
- for screws $6.8 \mu = 0.14$ (Stainless Steel version)

INFORMATION

Levelling sets GN 350 are used for levelling and linking operations. They comprise a threaded upper sleeve and a female threaded lower sleeve. The fine thread allows a stepless and precise setting and locking using the C-Spanner DIN 1810 (see page 994). A locking ring serves also as a height limiter for the max. height.

Normally this screw is permanently and securely locked by the static load created when the mounting screw is tightened.

Should this not be sufficient, the use of a locknut (Type AK) is recommended.

TECHNICAL INFORMATION

- Stainless Steel characteristics (see page A26)

ACCESSORY

- C-Spanner DIN 1810 (code no. see table)

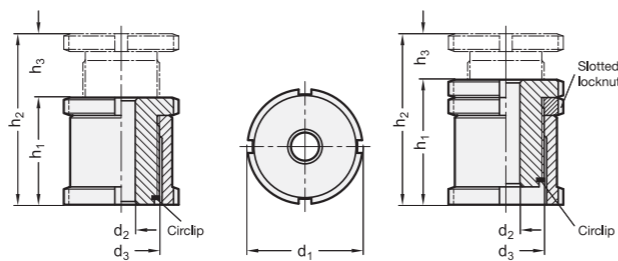

Type AK (with locknut)

Type A (without locknut)
with 2 spherical levelling washers

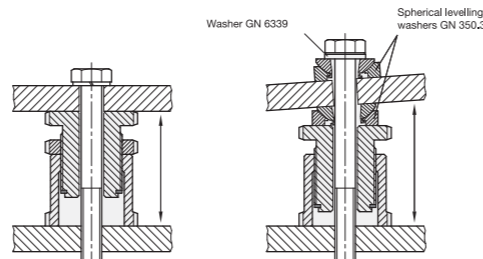

GN 350

Description	d1	d2	d3	h1	h2	h3	For screw	Static load F in kN F1	Static load F in kN F2	Code no. for C-Spanner	⚖
GN 350-25-6.6-A-ST	25	6.6	M 15 x 1	28	43	15	M 6	40	30.7	DIN 1810-A25-28	68
GN 350-32-6.6-A-ST	32	6.6	M 20 x 1	35	55	20	M 6	65	55.7	DIN 1810-A30-32	161
GN 350-32-9-A-ST	32	9	M 20 x 1	35	55	20	M 8	65	48	DIN 1810-A30-32	152
GN 350-32-11-A-ST	32	11	M 20 x 1	35	55	20	M 10	65	37.9	DIN 1810-A30-32	144
GN 350-45-11-A-ST	45	11	M 30 x 1.5	42	67	25	M 10	120	92.9	DIN 1810-A45-50	372
GN 350-45-13.5-A-ST	45	13.5	M 30 x 1.5	42	67	25	M 12	120	80.4	DIN 1810-A45-50	397
GN 350-45-17.5-A-ST	45	17.5	M 30 x 1.5	42	67	25	M 16	120	45.5	DIN 1810-A45-50	318
GN 350-58-17.5-A-ST	58	17.5	M 40 x 1.5	54	86	32	M 16	210	136	DIN 1810-A58-62	782
GN 350-58-22-A-ST	58	22	M 40 x 1.5	54	86	32	M 20	210	90	DIN 1810-A58-62	730
GN 350-58-26-A-ST	58	26	M 40 x 1.5	54	86	32	M 24	210	37	DIN 1810-A58-62	666
GN 350-70-22-A-ST	70	22	M 50 x 1.5	66	106	40	M 20	330	210	DIN 1810-A68-75	1440
GN 350-70-26-A-ST	70	26	M 50 x 1.5	66	106	40	M 24	330	157	DIN 1810-A68-75	1360
GN 350-70-33-A-ST	70	33	M 50 x 1.5	66	106	40	M 30	330	53	DIN 1810-A68-75	1200
GN 350-80-26-A-ST	80	26	M 60 x 2	76	126	50	M 24	495	322	DIN 1810-A80-90	2167
GN 350-80-33-A-ST	80	33	M 60 x 2	76	126	50	M 30	495	218	DIN 1810-A80-90	2000
GN 350-80-39-A-ST	80	39	M 60 x 2	76	126	50	M 36	495	101	DIN 1810-A80-90	1850

GN 350

Description	d1	d2	d3	h1	h2	h3	For screw	Static load F in kN F1	Static load F in kN F2	Code no. for C-Spanner	⚖
GN 350-25-6.6-AK-ST	25	6.6	M 15 x 1	33	43	10	M 6	40	30.7	DIN 1810-A25-28	78
GN 350-32-6.6-AK-ST	32	6.6	M 20 x 1	41	55	14	M 6	65	55.7	DIN 1810-A30-32	179
GN 350-32-9-AK-ST	32	9	M 20 x 1	41	55	14	M 8	65	48	DIN 1810-A30-32	172
GN 350-32-11-AK-ST	32	11	M 20 x 1	41	55	14	M 10	65	37.9	DIN 1810-A30-32	166
GN 350-45-11-AK-ST	45	11	M 30 x 1.5	49	67	18	M 10	120	92.9	DIN 1810-A45-50	409
GN 350-45-13.5-AK-ST	45	13.5	M 30 x 1.5	49	67	18	M 12	120	80.4	DIN 1810-A45-50	393
GN 350-45-17.5-AK-ST	45	17.5	M 30 x 1.5	49	67	18	M 16	120	45.5	DIN 1810-A45-50	365
GN 350-58-17.5-AK-ST	58	17.5	M 40 x 1.5	63	86	23	M 16	210	136	DIN 1810-A58-62	882
GN 350-58-22-AK-ST	58	22	M 40 x 1.5	63	86	23	M 20	210	90	DIN 1810-A58-62	823
GN 350-58-26-AK-ST	58	26	M 40 x 1.5	63	86	23	M 24	210	37	DIN 1810-A58-62	762
GN 350-70-22-AK-ST	70	22	M 50 x 1.5	77	106	29	M 20	330	210	DIN 1810-A68-75	1595
GN 350-70-26-AK-ST	70	26	M 50 x 1.5	77	106	29	M 24	330	157	DIN 1810-A68-75	1516
GN 350-70-33-AK-ST	70	33	M 50 x 1.5	77	106	29	M 30	330	53	DIN 1810-A68-75	1344
GN 350-80-26-AK-ST	80	26	M 60 x 2	87	126	39	M 24	495	322	DIN 1810-A80-90	2200
GN 350-80-33-AK-ST	80	33	M 60 x 2	87	126	39	M 30	495	218	DIN 1810-A80-90	2140
GN 350-80-39-AK-ST	80	39	M 60 x 2	87	126	39	M 36	495	101	DIN 1810-A80-90	1840

GN 350-NI

STAINLESS STEEL

Description	d1	d2	d3	h1	h2	h3	For screw	Static load F in kN F1	Static load F in kN F2	Code no. for C-Spanner	⚖
GN 350-25-6.6-A-NI	25	6.6	M 15 x 1	28	43	15	M 6	27.1	20.2	DIN 1810-A25-28	69
GN 350-32-6.6-A-NI	32	6.6	M 20 x 1	35	55	20	M 6	43.4	36.5	DIN 1810-A30-32	163
GN 350-32-9-A-NI	32	9	M 20 x 1	35	55	20	M 8	43.4	30.8	DIN 1810-A30-32	154
GN 350-32-11-A-NI	32	11	M 20 x 1	35	55	20	M 10	43.4	23.4	DIN 1810-A30-32	140
GN 350-45-11-A-NI	45	11	M 30 x 1.5	42	67	25	M 10	84	64	DIN 1810-A45-50	460
GN 350-45-13.5-A-NI	45	13.5	M 30 x 1.5	42	67	25	M 12	84	54.8	DIN 1810-A45-50	390
GN 350-45-17.5-A-NI	45	17.5	M 30 x 1.5	42	67	25	M 16	84	28.9	DIN 1810-A45-50	320
GN 350-58-17.5-A-NI	58	17.5	M 40 x 1.5	54	86	32	M 16	148	92.9	DIN 1810-A58-62	791
GN 350-58-22-A-NI	58	22	M 40 x 1.5	54	86	32	M 20	148	59	DIN 1810-A58-62	733
GN 350-58-26-A-NI	58	26	M 40 x 1.5	54	86	32	M 24	148	20.3	DIN 1810-A58-62	668
GN 350-70-22-A-NI	70	22	M 50 x 1.5	66	106	40	M 20	225	136	DIN 1810-A68-75	1452
GN 350-70-26-A-NI	70	26	M 50 x 1.5	66	106	40	M 24	225	97.3	DIN 1810-A68-75	1370
GN 350-70-33-A-NI	70	33	M 50 x 1.5	66	106	40	M 30	225	20.6	DIN 1810-A68-75	1210
GN 350-80-26-A-NI	80	26	M 60 x 2	76	126	50	M 24	323	195.3	DIN 1810-A80-90	2180
GN 350-80-33-A-NI	80	33	M 60 x 2	76	126	50	M 30	323	118.6	DIN 1810-A80-90	1875
GN 350-80-39-A-NI	80	39	M 60 x 2	76	126	50	M 36	323	38.2	DIN 1810-A80-90	1683
GN 350-25-6.6-AK-NI	25	6.6	M 15 x 1	33	43	10	M 6	27.1	20.2	DIN 1810-A25-28	79
GN 350-32-6.6-AK-NI	32	6.6	M 20 x 1	41	55	14	M 6	43.4	36.5	DIN 1810-A30-32	181
GN 350-32-9-AK-NI	32	9	M 20 x 1	41	55	14	M 8	43.4	30.8	DIN 1810-A30-32	174
GN 350-32-11-AK-NI	32	11	M 20 x 1	41	55	14	M 10	43.4	23.4	DIN 1810-A30-32	167
GN 350-45-11-AK-NI	45	11	M 30 x 1.5	49	67	18	M 10	84	64	DIN 1810-A45-50	411
GN 350-45-13.5-AK-NI	45	13.5	M 30 x 1.5	49	67	18	M 12	84	54.8	DIN 1810-A45-50	405
GN 350-45-17.5-AK-NI	45	17.5	M 30 x 1.5	49	67	18	M 16	84	28.9	DIN 1810-A45-50	377
GN 350-58-17.5-AK-NI	58	17.5	M 40 x 1.5	63	86	23	M 16	148	92.9	DIN 1810-A58-62	893
GN 350-58-22-AK-NI	58	22	M 40 x 1.5	63	86	23	M 20	148	59	DIN 1810-A58-62	834
GN 350-58-26-AK-NI	58	26	M 40 x 1.5	63	86	23	M 24	148	20.3	DIN 1810-A58-62	775
GN 350-70-22-AK-NI	70	22	M 50 x 1.5	77	106	29	M 20	225	136	DIN 1810-A68-75	1607
GN 350-70-26-AK-NI	70	26	M 50 x 1.5	77	106	29	M 24	225	97.3	DIN 1810-A68-75	1426
GN 350-70-33-AK-NI	70	33	M 50 x 1.5	77	106	29	M 30	225	20.6	DIN 1810-A68-75	1354
GN 350-80-26-AK-NI	80	26	M 60 x 2	87	126	39	M 24	323	195.3	DIN 1810-A80-90	2356
GN 350-80-33-AK-NI	80	33	M 60 x 2	87	126	39	M 30	323	118.6	DIN 1810-A80-90	2155
GN 350-80-39-AK-NI	80	39	M 60 x 2	87	126	39	M 36	323	38.2	DIN 1810-A80-90	1852

Levelling sets

Steel / Stainless Steel, short version

SPECIFICATION

Types

- Type **A**: without lock nut
- Type **AK**: with lock nut

Version in Steel

Steel, 1.7225 (42 CrMo 4V) **ST**
zinc plated, blue passivated

Version in Stainless Steel

Stainless Steel AISI 303 **NI**
(X 10 CrNiS 18-9)

F1: max. total load

F2: max. load after deduction of the max. preload

- for screws $8.8 \mu = 0.125$ (Steel version)
- for screws $6.8 \mu = 0.14$ (Stainless Steel version)

INFORMATION

Levelling sets GN 350.1 are used for levelling, adjusting and linking operations if small dimensions are given.

They comprise a threaded upper sleeve and a female threaded lower sleeve. The fine thread allows a stepless and precise setting and locking using the C-Spanner DIN 1810 (see page 994). A locking ring serves also as a height limiter for the max. height.

TECHNICAL INFORMATION

- Stainless Steel characteristics (see page A26)

ACCESSORY

- C-Spanner DIN 1810 (code no. see table)

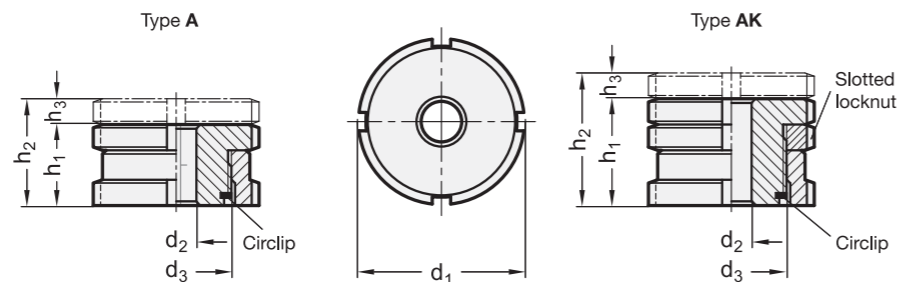

GN 350.1

Description	d1	d2	d3	h1	h2	h3	For screw	Static load F in kN F1	Static load F in kN F2	Code no. for C-Spanner	⚖
GN 350.1-25-6.6-A-ST	25	6.6	M 15 x 1	15	19	4	M 6	40	30.7	DIN 1810-A25-28	43
GN 350.1-32-6.6-A-ST	32	6.6	M 20 x 1	18	23	5	M 6	65	55.7	DIN 1810-A30-32	93
GN 350.1-32-9-A-ST	32	9	M 20 x 1	18	23	5	M 8	65	48	DIN 1810-A30-32	87
GN 350.1-32-11-A-ST	32	11	M 20 x 1	18	23	5	M 10	65	37.9	DIN 1810-A30-32	83
GN 350.1-45-11-A-ST	45	11	M 30 x 1.5	22	29	7	M 10	120	92.9	DIN 1810-A45-50	216
GN 350.1-45-13.5-A-ST	45	13.5	M 30 x 1.5	22	29	7	M 12	120	80.4	DIN 1810-A45-50	207
GN 350.1-45-17.5-A-ST	45	17.5	M 30 x 1.5	22	29	7	M 16	120	45.5	DIN 1810-A45-50	188
GN 350.1-58-17.5-A-ST	58	17.5	M 40 x 1.5	28	37	9	M 16	210	136	DIN 1810-A58-62	450
GN 350.1-58-22-A-ST	58	22	M 40 x 1.5	28	37	9	M 20	210	90	DIN 1810-A58-62	418
GN 350.1-58-26-A-ST	58	26	M 40 x 1.5	28	37	9	M 24	210	37	DIN 1810-A58-62	386
GN 350.1-70-22-A-ST	70	22	M 50 x 1.5	33	43	10	M 20	330	210	DIN 1810-A68-75	788
GN 350.1-70-26-A-ST	70	26	M 50 x 1.5	33	43	10	M 24	330	157	DIN 1810-A68-75	744
GN 350.1-70-33-A-ST	70	33	M 50 x 1.5	33	43	10	M 30	330	53	DIN 1810-A68-75	700
GN 350.1-80-26-A-ST	80	26	M 60 x 2	38	50	12	M 24	495	322	DIN 1810-A80-90	1135
GN 350.1-80-33-A-ST	80	33	M 60 x 2	38	50	12	M 30	495	218	DIN 1810-A80-90	1060
GN 350.1-80-39-A-ST	80	39	M 60 x 2	38	50	12	M 36	495	101	DIN 1810-A80-90	965

GN 350.1

Description	d1	d2	d3	h1	h2	h3	For screw	Static load F in kN F1	Static load F in kN F2	Code no. for C-Spanner	⚖
GN 350.1-25-6.6-AK-ST	25	6.6	M 15 x 1	20	24	4	M 6	40	30.7	DIN 1810-A25-28	58
GN 350.1-32-6.6-AK-ST	32	6.6	M 20 x 1	24	29	5	M 6	65	55.7	DIN 1810-A30-32	126
GN 350.1-32-9-AK-ST	32	9	M 20 x 1	24	29	5	M 8	65	48	DIN 1810-A30-32	118
GN 350.1-32-11-AK-ST	32	11	M 20 x 1	24	29	5	M 10	65	37.9	DIN 1810-A30-32	115
GN 350.1-45-11-AK-ST	45	11	M 30 x 1.5	29	36	7	M 10	120	92.9	DIN 1810-A45-50	318
GN 350.1-45-13.5-AK-ST	45	13.5	M 30 x 1.5	29	36	7	M 12	120	80.4	DIN 1810-A45-50	308
GN 350.1-45-17.5-AK-ST	45	17.5	M 30 x 1.5	29	36	7	M 16	120	45.5	DIN 1810-A45-50	254
GN 350.1-58-17.5-AK-ST	58	17.5	M 40 x 1.5	37	46	9	M 16	210	136	DIN 1810-A58-62	624
GN 350.1-58-22-AK-ST	58	22	M 40 x 1.5	37	46	9	M 20	210	90	DIN 1810-A58-62	620
GN 350.1-58-26-AK-ST	58	26	M 40 x 1.5	37	46	9	M 24	210	37	DIN 1810-A58-62	577
GN 350.1-70-22-AK-ST	70	22	M 50 x 1.5	44	54	10	M 20	330	210	DIN 1810-A68-75	1153
GN 350.1-70-26-AK-ST	70	26	M 50 x 1.5	44	54	10	M 24	330	157	DIN 1810-A68-75	1087
GN 350.1-70-33-AK-ST	70	33	M 50 x 1.5	44	54	10	M 30	330	53	DIN 1810-A68-75	974
GN 350.1-80-26-AK-ST	80	26	M 60 x 2	49	61	12	M 24	495	322	DIN 1810-A80-90	1565
GN 350.1-80-33-AK-ST	80	33	M 60 x 2	49	61	12	M 30	495	218	DIN 1810-A80-90	1440
GN 350.1-80-39-AK-ST	80	39	M 60 x 2	49	61	12	M 36	495	101	DIN 1810-A80-90	1314

GN 350.1-NI

STAINLESS STEEL

Description	d1	d2	d3	h1	h2	h3	For screw	Static load F in kN F1	Static load F in kN F2	Code no. for C-Spanner	⚖
GN 350.1-25-6.6-A-NI	25	6.6	M 15 x 1	15	19	4	M 6	27.1	20.2	DIN 1810-A25-28	43
GN 350.1-32-6.6-A-NI	32	6.6	M 20 x 1	18	23	5	M 6	43.4	36.5	DIN 1810-A30-32	93
GN 350.1-32-9-A-NI	32	9	M 20 x 1	18	23	5	M 8	43.4	30.8	DIN 1810-A30-32	87
GN 350.1-32-11-A-NI	32	11	M 20 x 1	18	23	5	M 10	43.4	23.4	DIN 1810-A30-32	60
GN 350.1-45-11-A-NI	45	11	M 30 x 1.5	22	29	7	M 10	84	64	DIN 1810-A45-50	216
GN 350.1-45-13.5-A-NI	45	13.5	M 30 x 1.5	22	29	7	M 12	84	54.8	DIN 1810-A45-50	207
GN 350.1-45-17.5-A-NI	45	17.5	M 30 x 1.5	22	29	7	M 16	84	28.9	DIN 1810-A45-50	188
GN 350.1-58-17.5-A-NI	58	17.5	M 40 x 1.5	28	37	9	M 16	148	92.9	DIN 1810-A58-62	450
GN 350.1-58-22-A-NI	58	22	M 40 x 1.5	28	37	9	M 20	148	59	DIN 1810-A58-62	418
GN 350.1-58-26-A-NI	58	26	M 40 x 1.5	28	37	9	M 24	148	20.3	DIN 1810-A58-62	386
GN 350.1-70-22-A-NI	70	22	M 50 x 1.5	33	43	10	M 20	225	136	DIN 1810-A68-75	788
GN 350.1-70-26-A-NI	70	26	M 50 x 1.5	33	43	10	M 24	225	97.3	DIN 1810-A68-75	744
GN 350.1-70-33-A-NI	70	33	M 50 x 1.5	33	43	10	M 30	225	20.6	DIN 1810-A68-75	668
GN 350.1-80-26-A-NI	80	26	M 60 x 2	38	50	12	M 24	323	195.3	DIN 1810-A80-90	1135
GN 350.1-80-33-A-NI	80	33	M 60 x 2	38	50	12	M 30	323	118.6	DIN 1810-A80-90	1060
GN 350.1-80-39-A-NI	80	39	M 60 x 2	38	50	12	M 36	323	38.2	DIN 1810-A80-90	965
GN 350.1-25-6.6-AK-NI	25	6.6	M 15 x 1	20	24	4	M 6	27.1	20.2	DIN 1810-A25-28	159
GN 350.1-32-6.6-AK-NI	32	6.6	M 20 x 1	24	29	5	M 6	43.4	36.5	DIN 1810-A30-32	128
GN 350.1-32-9-AK-NI	32	9	M 20 x 1	24	29	5	M 8	43.4	30.8	DIN 1810-A30-32	119
GN 350.1-32-11-AK-NI	32	11	M 20 x 1	24	29	5	M 10	43.4	23.4	DIN 1810-A30-32	114
GN 350.1-45-11-AK-NI	45	11	M 30 x 1.5	29	36	7	M 10	84	64	DIN 1810-A45-50	320
GN 350.1-45-13.5-AK-NI	45	13.5	M 30 x 1.5	29	36	7	M 12	84	54.8	DIN 1810-A45-50	209
GN 350.1-45-17.5-AK-NI	45	17.5	M 30 x 1.5	29	36	7	M 16	84	28.9	DIN 1810-A45-50	289
GN 350.1-58-17.5-AK-NI	58	17.5	M 40 x 1.5	37	46	9	M 16	148	92.9	DIN 1810-A58-62	665
GN 350.1-58-22-AK-NI	58	22	M 40 x 1.5	37	46	9	M 20	148	59	DIN 1810-A58-62	618
GN 350.1-58-26-AK-NI	58	26	M 40 x 1.5	37	46	9	M 24	148	20.3	DIN 1810-A58-62	574
GN 350.1-70-22-AK-NI	70	22	M 50 x 1.5	44	54	10	M 20	225	136	DIN 1810-A68-75	1123
GN 350.1-70-26-AK-NI	70	26	M 50 x 1.5	44	54	10	M 24	225	97.3	DIN 1810-A68-75	1069
GN 350.1-70-33-AK-NI	70	33	M 50 x 1.5	44	54	10	M 30	225	20.6	DIN 1810-A68-75	756
GN 350.1-80-26-AK-NI	80	26	M 60 x 2	49	61	12	M 24	323	195.3	DIN 1810-A80-90	1565
GN 350.1-80-33-AK-NI	80	33	M 60 x 2	49	61	12	M 30	323	118.6	DIN 1810-A80-90	1440
GN 350.1-80-39-AK-NI	80	39	M 60 x 2	49	61	12	M 36	323	38.2	DIN 1810-A80-90	1310

Levelling sets

Steel / Stainless Steel, with spherical washer, without locknut

SPECIFICATION

Version in Steel

Steel, 1.7225 (42 CrMo 4V) ST
zinc plated, blue passivated

Version in Stainless Steel

Stainless Steel AISI 303 NI
(X 10 CrNiS 18-9)

F1: max. total load

F2: max. load after deduction of the max. preload

- for screws $8.8 \mu = 0.125$ (Steel version)
- for screws $6.8 \mu = 0.14$ (Stainless Steel version)

INFORMATION

Levelling sets GN 350.2 are used for levelling, adjusting and linking operations. The spherical washer allows precise installation of two non parallel planes at a required gradient up to $\approx 4^\circ$.

They comprise a threaded upper sleeve and a female threaded lower sleeve. The fine thread allows a stepless and precise setting and locking using the C-Spanner DIN 1810 (see page 994). A locking ring serves also as a height limiter for the max. height.

TECHNICAL INFORMATION

- Stainless Steel characteristics (see page A26)

ACCESSORY

- C-Spanner DIN 1810 (code no. see table)

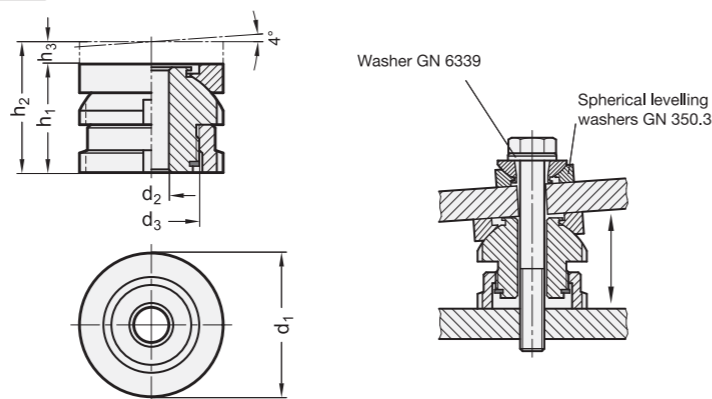

GN 350.2

Description	d1	d2	h1	d3	h2	h3	For screw	Static load F in kN F1	Static load F in kN F2	Code no. for C-Spanner	⚖
GN 350.2-25-6.6-22-ST	25	6.6	22	M 15 x 1	26	4	M 6	40	30.7	DIN 1810-A25-28	67
GN 350.2-25-6.6-35-ST	25	6.6	35	M 15 x 1	50	15	M 6	40	30.7	DIN 1810-A25-28	82
GN 350.2-32-6.6-26-ST	32	6.6	26	M 20 x 1	31	5	M 6	65	55.7	DIN 1810-A30-32	132
GN 350.2-32-6.6-43-ST	32	6.6	43	M 20 x 1	63	20	M 6	65	55.7	DIN 1810-A30-32	212
GN 350.2-32-9-26-ST	32	9	26	M 20 x 1	31	5	M 8	65	48	DIN 1810-A30-32	131
GN 350.2-32-9-43-ST	32	9	43	M 20 x 1	63	20	M 8	65	48	DIN 1810-A30-32	201
GN 350.2-32-11-26-ST	32	11	26	M 20 x 1	31	5	M 10	65	37.9	DIN 1810-A30-32	120
GN 350.2-32-11-43-ST	32	11	43	M 20 x 1	63	20	M 10	65	37.9	DIN 1810-A30-32	191
GN 350.2-45-11-34-ST	45	11	34	M 30 x 1.5	41	7	M 10	120	92.9	DIN 1810-A45-50	355
GN 350.2-45-11-54-ST	45	11	54	M 30 x 1.5	79	25	M 10	120	92.9	DIN 1810-A45-50	555
GN 350.2-45-13.5-34-ST	45	13.5	34	M 30 x 1.5	41	7	M 12	120	80.4	DIN 1810-A45-50	307
GN 350.2-45-13.5-54-ST	45	13.5	54	M 30 x 1.5	79	25	M 12	120	80.4	DIN 1810-A45-50	539
GN 350.2-45-17.5-34-ST	45	17.5	34	M 30 x 1.5	41	7	M 16	120	45.5	DIN 1810-A45-50	280
GN 350.2-45-17.5-54-ST	45	17.5	54	M 30 x 1.5	79	25	M 16	120	45.5	DIN 1810-A45-50	510
GN 350.2-58-17.5-44-ST	58	17.5	44	M 40 x 1.5	53	9	M 16	210	136	DIN 1810-A58-62	740
GN 350.2-58-17.5-70-ST	58	17.5	70	M 40 x 1.5	102	32	M 16	210	136	DIN 1810-A58-62	1092

GN 350.2

Description	d1	d2	h1	d3	h2	h3	For screw	Static load F in kN F1	Static load F in kN F2	Code no. for C-Spanner	⚖
GN 350.2-58-22-44-ST	58	22	44	M 40 x 1.5	53	9	M 20	210	90	DIN 1810-A58-62	610
GN 350.2-58-22-70-ST	58	22	70	M 40 x 1.5	102	32	M 20	210	90	DIN 1810-A58-62	1031
GN 350.2-58-26-44-ST	58	26	44	M 40 x 1.5	53	9	M 24	210	37	DIN 1810-A58-62	560
GN 350.2-58-26-70-ST	58	26	70	M 40 x 1.5	102	32	M 24	210	37	DIN 1810-A58-62	955
GN 350.2-70-22-50-ST	70	22	50	M 50 x 1.5	60	10	M 20	330	210	DIN 1810-A68-75	1000
GN 350.2-70-22-83-ST	70	22	83	M 50 x 1.5	123	40	M 20	330	210	DIN 1810-A68-75	1896
GN 350.2-70-26-50-ST	70	26	50	M 50 x 1.5	60	10	M 24	330	157	DIN 1810-A68-75	940
GN 350.2-70-26-83-ST	70	26	83	M 50 x 1.5	123	40	M 24	330	157	DIN 1810-A68-75	1802
GN 350.2-70-33-50-ST	70	33	50	M 50 x 1.5	60	10	M 30	330	53	DIN 1810-A68-75	815
GN 350.2-70-33-83-ST	70	33	83	M 50 x 1.5	123	40	M 30	330	53	DIN 1810-A68-75	1599
GN 350.2-80-26-56-ST	80	26	56	M 60 x 2	68	12	M 24	495	322	DIN 1810-A80-90	1140
GN 350.2-80-26-94-ST	80	26	94	M 60 x 2	144	50	M 24	495	322	DIN 1810-A80-90	2885
GN 350.2-80-33-56-ST	80	33	56	M 60 x 2	68	12	M 30	495	218	DIN 1810-A80-90	1000
GN 350.2-80-33-94-ST	80	33	94	M 60 x 2	144	50	M 30	495	218	DIN 1810-A80-90	2560
GN 350.2-80-39-56-ST	80	39	56	M 60 x 2	68	12	M 36	495	101	DIN 1810-A80-90	1440
GN 350.2-80-39-94-ST	80	39	94	M 60 x 2	144	50	M 36	495	101	DIN 1810-A80-90	2232

GN 350.2-NI

STAINLESS STEEL

Description	d1	d2	h1	d3	h2	h3	For screw	Static load F in kN F1	Static load F in kN F2	Code no. for C-Spanner	⚖
GN 350.2-25-6.6-22-NI	25	6.6	22	M 15 x 1	26	4	M 6	27.1	20.26	DIN 1810-A25-28	66
GN 350.2-25-6.6-35-NI	25	6.6	35	M 15 x 1	50	15	M 6	27.1	20.26	DIN 1810-A25-28	100
GN 350.2-32-6.6-26-NI	32	6.6	26	M 20 x 1	31	5	M 6	43.4	36.56	DIN 1810-A30-32	132
GN 350.2-32-6.6-43-NI	32	6.6	43	M 20 x 1	63	20	M 6	43.4	36.56	DIN 1810-A30-32	216
GN 350.2-32-9-26-NI	32	9	26	M 20 x 1	31	5	M 8	43.4	30.86	DIN 1810-A30-32	131
GN 350.2-32-9-43-NI	32	9	43	M 20 x 1	63	20	M 8	43.4	30.86	DIN 1810-A30-32	200
GN 350.2-32-11-26-NI	32	11	26	M 20 x 1	31	5	M 10	43.4	23.41	DIN 1810-A30-32	120
GN 350.2-32-11-43-NI	32	11	43	M 20 x 1	63	20	M 10	43.4	23.41	DIN 1810-A30-32	179
GN 350.2-45-11-34-NI	45	11	34	M 30 x 1.5	41	7	M 10	84	64.01	DIN 1810-A45-50	355
GN 350.2-45-11-54-NI	45	11	54	M 30 x 1.5	79	25	M 10	84	64.01	DIN 1810-A45-50	553
GN 350.2-45-13.5-34-NI	45	13.5	34	M 30 x 1.5	41	7	M 12	84	54.82	DIN 1810-A45-50	307
GN 350.2-45-13.5-54-NI	45	13.5	54	M 30 x 1.5	79	25	M 12	84	54.82	DIN 1810-A45-50	547
GN 350.2-45-17.5-34-NI	45	17.5	34	M 30 x 1.5	41	7	M 16	84	28.9	DIN 1810-A45-50	280
GN 350.2-45-17.5-54-NI	45	17.5	54	M 30 x 1.5	79	25	M 16	84	28.9	DIN 1810-A45-50	513
GN 350.2-58-17.5-44-NI	58	17.5	44	M 40 x 1.5	53	9	M 16	148	92.9	DIN 1810-A58-62	665
GN 350.2-58-17.5-70-NI	58	17.5	70	M 40 x 1.5	102	32	M 16	148	92.9	DIN 1810-A58-62	904
GN 350.2-58-22-44-NI	58	22	44	M 40 x 1.5	53	9	M 20	148	59.08	DIN 1810-A58-62	900
GN 350.2-58-22-70-NI	58	22	70	M 40 x 1.5	102	32	M 20	148	59.08	DIN 1810-A58-62	680
GN 350.2-58-26-44-NI	58	26	44	M 40 x 1.5	53	9	M 24	148	20.3	DIN 1810-A58-62	800
GN 350.2-58-26-70-NI	58	26	70	M 40 x 1.5	102	32	M 24	148	20.3	DIN 1810-A58-62	950
GN 350.2-70-22-50-NI	70	22	50	M 50 x 1.5	60	10	M 20	225	136.08	DIN 1810-A68-75	1300
GN 350.2-70-22-83-NI	70	22	83	M 50 x 1.5	123	40	M 20	225	136.08	DIN 1810-A68-75	1916
GN 350.2-70-26-50-NI	70	26	50	M 50 x 1.5	60	10	M 24	225	97.3	DIN 1810-A68-75	940
GN 350.2-70-26-83-NI	70	26	83	M 50 x 1.5	123	40	M 24	225	97.3	DIN 1810-A68-75	1823
GN 350.2-70-33-50-NI	70	33	50	M 50 x 1.5	60	10	M 30	225	20.6	DIN 1810-A68-75	1815
GN 350.2-70-33-83-NI	70	33	83	M 50 x 1.5	123	40	M 30	225	20.6	DIN 1810-A68-75	1618
GN 350.2-80-26-56-NI	80	26	56	M 60 x 2	68	12	M 24	323	195.3	DIN 1810-A80-90	1140
GN 350.2-80-26-94-NI	80	26	94	M 60 x 2	144	50	M 24	323	195.3	DIN 1810-A80-90	1888
GN 350.2-80-33-56-NI	80	33	56	M 60 x 2	68	12	M 30	323	118.6	DIN 1810-A80-90	1580
GN 350.2-80-33-94-NI	80	33	94	M 60 x 2	144	50	M 30	323	118.6	DIN 1810-A80-90	2492
GN 350.2-80-39-56-NI	80	39	56	M 60 x 2	68	12	M 36	323	38.2	DIN 1810-A80-90	2589
GN 350.2-80-39-94-NI	80	39	94	M 60 x 2	144	50	M 36	323	38.2	DIN 1810-A80-90	2865

Levelling sets

Steel / Stainless Steel, with spherical washer, with locknut

SPECIFICATION

Version in Steel

Steel, 1.7225 (42 CrMo 4V) ST
zinc plated, blue passivated

Version in Stainless Steel

Stainless Steel AISI 303
(X 10 CrNiS 18-9) NI

F1: max. total load

F2: max. load after deduction of the max. preload

- for screws $8.8 \mu = 0.125$ (Steel version)
- for screws $6.8 \mu = 0.14$ (Stainless Steel version)

INFORMATION

Levelling sets GN 350.5 are used for levelling, adjusting and linking operations. The spherical washer allows precise installation of two non parallel planes at a required gradient up to $\approx 4^\circ$.

They comprise a threaded upper sleeve and a female threaded lower sleeve. The fine thread allows a stepless and precise setting and locking using the C-Spanner DIN 1810 (see page 994). A locking ring serves also as a height limiter for the max. height.

TECHNICAL INFORMATION

- Stainless Steel characteristics (see page A26)

ACCESSORY

- C-Spanner DIN 1810 (code no. see table)

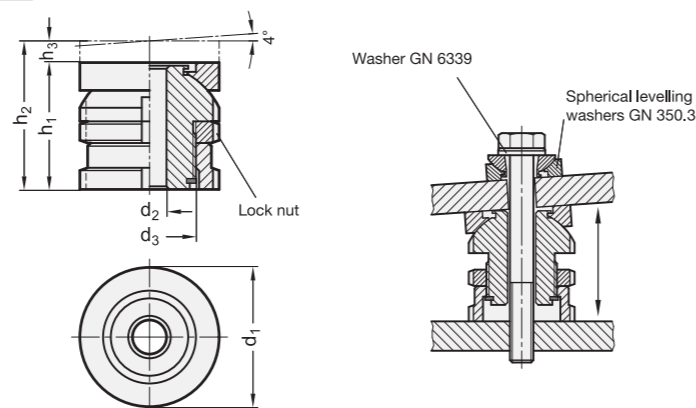

GN 350.5

Description	d1	d2	h1	d3	h2	h3	For screw	Static load F in kN F1	Static load F in kN F2	Code no. for C-Spanner	⚖️
GN 350.5-25-6.6-27-ST	25	6.6	27	M 15 x 1	31	4	M 6	40	30.7	DIN 1810-A25-28	80
GN 350.5-25-6.6-40-ST	25	6.6	40	M 15 x 1	50	10	M 6	40	30.7	DIN 1810-A25-28	85
GN 350.5-32-6.6-32-ST	32	6.6	32	M 20 x 1	37	5	M 6	65	55.7	DIN 1810-A30-32	140
GN 350.5-32-6.6-49-ST	32	6.6	49	M 20 x 1	63	14	M 6	65	55.7	DIN 1810-A30-32	147
GN 350.5-32-9-32-ST	32	9	32	M 20 x 1	37	5	M 8	65	48	DIN 1810-A30-32	130
GN 350.5-32-9-49-ST	32	9	49	M 20 x 1	63	14	M 8	65	48	DIN 1810-A30-32	147
GN 350.5-32-11-32-ST	32	11	32	M 20 x 1	37	5	M 10	65	37.9	DIN 1810-A30-32	120
GN 350.5-32-11-49-ST	32	11	49	M 20 x 1	63	14	M 10	65	37.9	DIN 1810-A30-32	200
GN 350.5-45-11-41-ST	45	11	41	M 30 x 1.5	48	7	M 10	120	92.9	DIN 1810-A45-50	360
GN 350.5-45-11-61-ST	45	11	61	M 30 x 1.5	79	18	M 10	120	92.9	DIN 1810-A45-50	399
GN 350.5-45-13.5-41-ST	45	13.5	41	M 30 x 1.5	48	7	M 12	120	80.4	DIN 1810-A45-50	350
GN 350.5-45-13.5-61-ST	45	13.5	61	M 30 x 1.5	79	18	M 12	120	80.4	DIN 1810-A45-50	390
GN 350.5-45-17.5-41-ST	45	17.5	41	M 30 x 1.5	48	7	M 16	120	45.5	DIN 1810-A45-50	400
GN 350.5-45-17.5-61-ST	45	17.5	61	M 30 x 1.5	79	18	M 16	120	45.5	DIN 1810-A45-50	480
GN 350.5-58-17.5-53-ST	58	17.5	53	M 40 x 1.5	62	9	M 16	210	136	DIN 1810-A58-62	940
GN 350.5-58-17.5-79-ST	58	17.5	79	M 40 x 1.5	102	23	M 16	210	136	DIN 1810-A58-62	1189

GN 350.5

Description	d1	d2	h1	d3	h2	h3	For screw	Static load F in kN F1	Static load F in kN F2	Code no. for C-Spanner	⚖️
GN 350.5-58-22-53-ST	58	22	53	M 40 x 1.5	62	9	M 20	210	90	DIN 1810-A58-62	770
GN 350.5-58-22-79-ST	58	22	79	M 40 x 1.5	102	23	M 20	210	90	DIN 1810-A58-62	840
GN 350.5-58-26-53-ST	58	26	53	M 40 x 1.5	62	9	M 24	210	37	DIN 1810-A58-62	760
GN 350.5-58-26-79-ST	58	26	79	M 40 x 1.5	102	23	M 24	210	37	DIN 1810-A58-62	830
GN 350.5-70-22-61-ST	70	22	61	M 50 x 1.5	71	10	M 20	330	210	DIN 1810-A68-75	1600
GN 350.5-70-22-94-ST	70	22	94	M 50 x 1.5	123	29	M 20	330	210	DIN 1810-A68-75	1900
GN 350.5-70-26-61-ST	70	26	61	M 50 x 1.5	71	10	M 24	330	157	DIN 1810-A68-75	1200
GN 350.5-70-26-94-ST	70	26	94	M 50 x 1.5	123	29	M 24	330	157	DIN 1810-A68-75	1300
GN 350.5-70-33-61-ST	70	33	61	M 50 x 1.5	71	10	M 30	330	53	DIN 1810-A68-75	1100
GN 350.5-70-33-94-ST	70	33	94	M 50 x 1.5	123	29	M 30	330	53	DIN 1810-A68-75	1200
GN 350.5-80-26-67-ST	80	26	67	M 60 x 2	79	12	M 24	495	322	DIN 1810-A80-90	1650
GN 350.5-80-26-105-ST	80	26	105	M 60 x 2	144	39	M 24	495	322	DIN 1810-A80-90	2100
GN 350.5-80-33-67-ST	80	33	67	M 60 x 2	79	12	M 30	495	218	DIN 1810-A80-90	1550
GN 350.5-80-33-105-ST	80	33	105	M 60 x 2	144	39	M 30	495	218	DIN 1810-A80-90	1911
GN 350.5-80-39-67-ST	80	39	67	M 60 x 2	79	12	M 36	495	101	DIN 1810-A80-90	1450
GN 350.5-80-39-105-ST	80	39	105	M 60 x 2	144	39	M 36	495	101	DIN 1810-A80-90	1950

GN 350.5-NI

STAINLESS STEEL

Description	d1	d2	h1	d3	h2	h3	For screw	Static load F in kN F1	Static load F in kN F2	Code no. for C-Spanner	⚖️
GN 350.5-25-6.6-27-NI	25	6.6	27	M 15 x 1	31	4	M 6	27.1	20.26	DIN 1810-A25-28	80
GN 350.5-25-6.6-40-NI	25	6.6	40	M 15 x 1	50	10	M 6	27.1	20.26	DIN 1810-A25-28	85
GN 350.5-32-6.6-32-NI	32	6.6	32	M 20 x 1	37	5	M 6	43.4	36.56	DIN 1810-A30-32	140
GN 350.5-32-6.6-49-NI	32	6.6	49	M 20 x 1	63	14	M 6	43.4	36.56	DIN 1810-A30-32	147
GN 350.5-32-9-32-NI	32	9	32	M 20 x 1	37	5	M 8	43.4	30.86	DIN 1810-A30-32	130
GN 350.5-32-9-49-NI	32	9	49	M 20 x 1	63	14	M 8	43.4	30.86	DIN 1810-A30-32	147
GN 350.5-32-11-32-NI	32	11	32	M 20 x 1	37	5	M 10	43.4	23.41	DIN 1810-A30-32	120
GN 350.5-32-11-49-NI	32	11	49	M 20 x 1	63	14	M 10	43.4	23.41	DIN 1810-A30-32	127
GN 350.5-45-11-41-NI	45	11	41	M 30 x 1.5	48	7	M 10	84	64.01	DIN 1810-A45-50	360
GN 350.5-45-11-61-NI	45	11	61	M 30 x 1.5	79	18	M 10	84	64.01	DIN 1810-A45-50	370
GN 350.5-45-13.5-41-NI	45	13.5	41	M 30 x 1.5	48	7	M 12	84	54.82	DIN 1810-A45-50	350
GN 350.5-45-13.5-61-NI	45	13.5	61	M 30 x 1.5	79	18	M 12	84	54.82	DIN 1810-A45-50	390
GN 350.5-45-17.5-41-NI	45	17.5	41	M 30 x 1.5	48	7	M 16	84	28.9	DIN 1810-A45-50	340
GN 350.5-45-17.5-61-NI	45	17.5	61	M 30 x 1.5	79	18	M 16	84	28.9	DIN 1810-A45-50	380
GN 350.5-58-17.5-53-NI	58	17.5	53	M 40 x 1.5	62	9	M 16	148	92.9	DIN 1810-A58-62	780
GN 350.5-58-17.5-79-NI	58	17.5	79	M 40 x 1.5	102	23	M 16	148	92.9	DIN 1810-A58-62	1184
GN 350.5-58-22-53-NI	58	22	53	M 40 x 1.5	62	9	M 20	148	59.08	DIN 1810-A58-62	770
GN 350.5-58-22-79-NI	58	22	79	M 40 x 1.5	102	23	M 20	148	59.08	DIN 1810-A58-62	840
GN 350.5-58-26-53-NI	58	26	53	M 40 x 1.5	62	9	M 24	148	20.3	DIN 1810-A58-62	760
GN 350.5-58-26-79-NI	58	26	79	M 40 x 1.5	102	23	M 24	148	20.3	DIN 1810-A58-62	860
GN 350.5-70-22-61-NI	70	22	61	M 50 x 1.5	71	10	M 20	225	136.08	DIN 1810-A68-75	1300
GN 350.5-70-22-94-NI	70	22	94	M 50 x 1.5	123	29	M 20	225	136.08	DIN 1810-A68-75	1418
GN 350.5-70-26-61-NI	70	26	61	M 50 x 1.5	71	10	M 24	225	97.3	DIN 1810-A68-75	1200
GN 350.5-70-26-94-NI	70	26	94	M 50 x 1.5	123	29	M 24	225	97.3	DIN 1810-A68-75	1400
GN 350.5-70-33-61-NI	70	33	61	M 50 x 1.5	71	10	M 30	225	20.6	DIN 1810-A68-75	1100
GN 350.5-70-33-94-NI	70	33	94	M 50 x 1.5	123	29	M 30	225	20.6	DIN 1810-A68-75	1200
GN 350.5-80-26-67-NI	80	26	67	M 60 x 2	79	12	M 24	323	195.3	DIN 1810-A80-90	1650
GN 350.5-80-26-105-NI	80	26	105	M 60 x 2	144	39	M 24	323	195.3	DIN 1810-A80-90	2900
GN 350.5-80-33-67-NI	80	33	67	M 60 x 2	79	12	M 30	323	118.6	DIN 1810-A80-90	1550
GN 350.5-80-33-105-NI	80	33	105	M 60 x 2	144	39	M 30	323	118.6	DIN 1810-A80-90	1911
GN 350.5-80-39-67-NI	80	39	67	M 60 x 2	79	12	M 36	323	38.2	DIN 1810-A80-90	1450
GN 350.5-80-39-105-NI	80	39	105	M 60 x 2	144	39	M 36	323	38.2	DIN 1810-A80-90	1811

Positioning elements

with male thread

SPECIFICATION

Types

- Type **B**: Smooth contact face
- Type **K**: Spherical contact face
- Type **R**: Serrated contact face

Steel

- case hardened
- blackened

INFORMATION

Positioning elements GN 409.1 with male thread are designe for use as locating plungers, stops and thrust blocks.



Application example

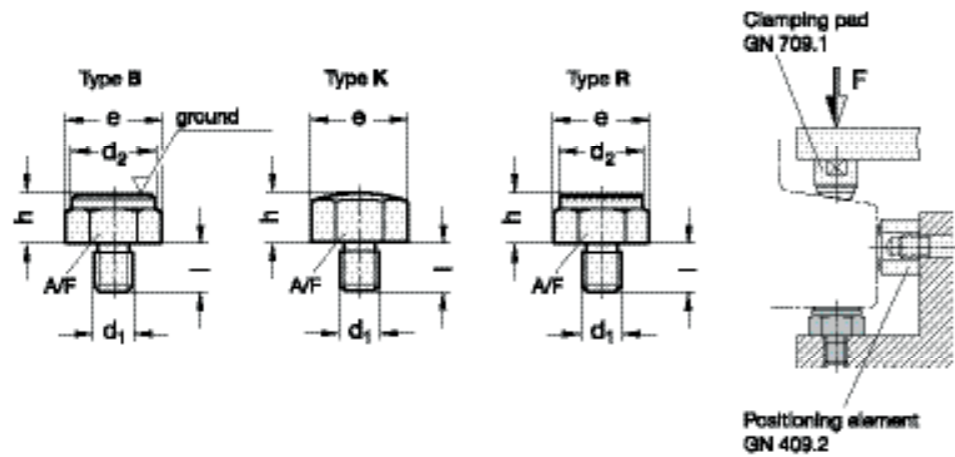

GN 409.1

Description	h ±0.01	h ±0.1	d1	d2	l	A/F	e	ΔΔ
GN 409.1-10-M8-B	10	-	M 8	17	10	17	19.4	21
GN 409.1-10-M10-B	10	-	M 10	19	12	19	21.9	28
GN 409.1-10-M12-B	10	-	M 12	22	14	22	25.2	40
GN 409.1-15-M10-B	15	-	M 10	19	12	19	21.9	40
GN 409.1-15-M12-B	15	-	M 12	22	14	22	25.2	56
GN 409.1-15-M16-B	15	-	M 16	30	19	30	33	110
GN 409.1-20-M16-B	20	-	M 16	30	19	30	33	140
GN 409.1-10-M8-K	-	10	M 8	-	10	17	19.4	20
GN 409.1-10-M10-K	-	10	M 10	-	12	19	21.9	27
GN 409.1-10-M12-K	-	10	M 12	-	14	22	25.2	37
GN 409.1-15-M10-K	-	15	M 10	-	12	19	21.9	40
GN 409.1-15-M12-K	-	15	M 12	-	14	22	25.2	54
GN 409.1-15-M16-K	-	15	M 16	-	19	30	33	105
GN 409.1-20-M16-K	-	20	M 16	-	19	30	33	135
GN 409.1-10-M8-R	-	10	M 8	17	10	17	19.4	20
GN 409.1-10-M10-R	-	10	M 10	19	12	19	21.9	26
GN 409.1-10-M12-R	-	10	M 12	22	14	22	25.2	38
GN 409.1-15-M10-R	-	15	M 10	19	12	19	21.9	39
GN 409.1-15-M12-R	-	15	M 12	22	14	22	25.2	54
GN 409.1-15-M16-R	-	15	M 16	30	19	30	33	106
GN 409.1-20-M16-R	-	20	M 16	30	19	30	33	136

Positioning elements

with female thread

SPECIFICATION

Types

- Type **B**: Smooth contact face
- Type **K**: Spherical contact face
- Type **R**: Serrated contact face

Steel

- hardened
- blackened

INFORMATION

Positioning elements GN 409.2 with male thread are designe for use as locating plungers, stops and thrust blocks.



Application example

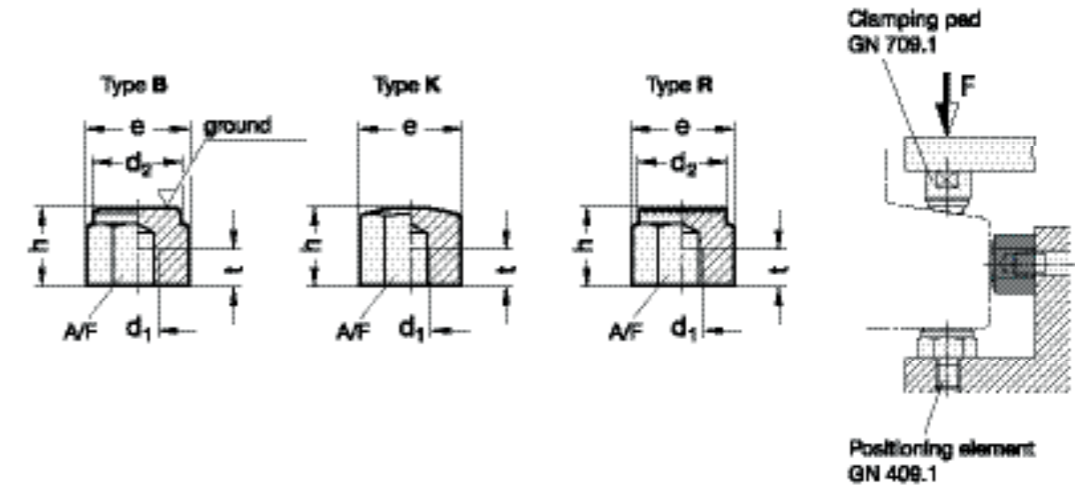

*Complete with type index of the Positioning elements

B **K** **R**

GN 409.2

Description	h ±0.01 Type B	h ±0.1 Type K/R	d1	d2	t min.	A/F	e	ΔΔ
GN 409.2-15-M8-*	15	15	M 8	17	6	17	19.4	25
GN 409.2-20-M10-*	20	20	M 10	19	10	19	21.9	39
GN 409.2-20-M12-*	20	20	M 12	22	10	22	25.2	52
GN 409.2-25-M8-*	25	25	M 8	17	12	17	19.4	42
GN 409.2-25-M12-*	25	25	M 12	22	15	22	25.2	47
GN 409.2-30-M10-*	30	30	M 10	19	15	19	21.9	61
GN 409.2-30-M12-*	30	30	M 12	22	18	22	25.2	79
GN 409.2-30-M16-*	30	30	M 16	30	20	30	33	136
GN 409.2-40-M10-*	40	40	M 10	19	15	19	21.9	85
GN 409.2-40-M12-*	40	40	M 12	22	18	22	25.2	110
GN 409.2-50-M12-*	50	50	M 12	22	18	22	25.2	142
GN 409.2-50-M16-*	50	50	M 16	30	24	30	33	270

Weight type B



Feet

SPECIFICATION

Steel (German Material No. 1.0718)

- not hardened
- blackened

INFORMATION

Feet DIN 6320 are normally used in jig construction if neither a self-aligning support nor an axial adjustment is required.

Unlike the models specified in the official standard sheet, these feet are made of 1.0718 steel (in place of quenched and tempered steel).

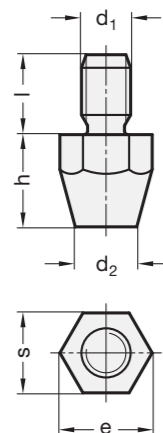

Headed dowels

SPECIFICATION

Steel
hardened

INFORMATION

Headed dowels GN 6321.1 can also be used as feet.

TECHNICAL INFORMATION

- ISO-Fundamental Tolerances (see page A21)

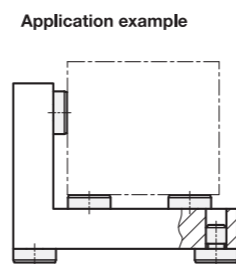
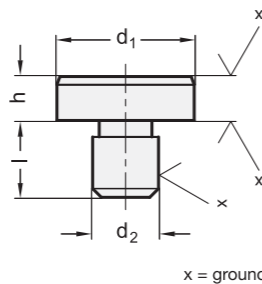

x = ground

GN 6321.1

Description	d1	d2 n6	h h9	l	⚖
GN 6321.1-6-2,5	6	4	2.5	6.5	1
GN 6321.1-6-4,5	6	4	4.5	8.5	2
GN 6321.1-6-5	6	4	5	6	2
GN 6321.1-10-4,5	10	6	4.5	8.5	4
GN 6321.1-10-8	10	6	8	8	6
GN 6321.1-16-5	16	8	5	10	11
GN 6321.1-16-13	16	8	13	10	23
GN 6321.1-20-6	20	10	6	12	21
GN 6321.1-20-12	20	10	12	12	35
GN 6321.1-25-8	25	12	8	14	41
GN 6321.1-25-20	25	12	20	14	87
GN 6321.1-25-30	25	12	30	14	124
GN 6321.1-30-25	30	16	25	20	164
GN 6321.1-30-40	30	16	40	20	248
GN 6321.1-30-50	30	16	50	20	305
GN 6321.1-30-65	30	16	65	20	385
GN 6321.1-40-13	40	20	13	20	171
GN 6321.1-40-32	40	20	32	20	357

DIN 6320

Description	h	d1	d2	e min.	l	s	⚖
DIN 6320-10-M6	10	M 6	8	11.5	11	10	8
DIN 6320-15-M8	15	M 8	10	15	13	13	20
DIN 6320-20-M6	20	M 6	6	11.5	11	10	15
DIN 6320-20-M10	20	M 10	13	19.6	16	17	42
DIN 6320-25-M12	25	M 12	15	21.9	20	19	60
DIN 6320-30-M8	30	M 8	9	15	13	13	35
DIN 6320-40-M10	40	M 10	13	19.6	16	17	80
DIN 6320-50-M12	50	M 12	15	21.9	20	19	130



Workholding bolts / Headed dowels

SPECIFICATION

Types

- Type **A**: Headed dowel, low type
- Type **B**: Workholding bolt, high, cylindrical
- Type **C**: Workholding bolt, high, flattened

Steel

- hardened
- blackened

Type A
without centre hole

Type B / Type C
with centre hole



INFORMATION

Workholding bolts DIN 6321 are inserted into bores for positioning, assisted by the flattened design (Form C) to compensate tolerances in the spacing of two bores. Another application of this design is to fix parts to be positioned in one direction only.

Types A and B can also be used as bearing surfaces, stops or as foot.

TECHNICAL INFORMATION

- ISO-Fundamental Tolerances (see page A21)

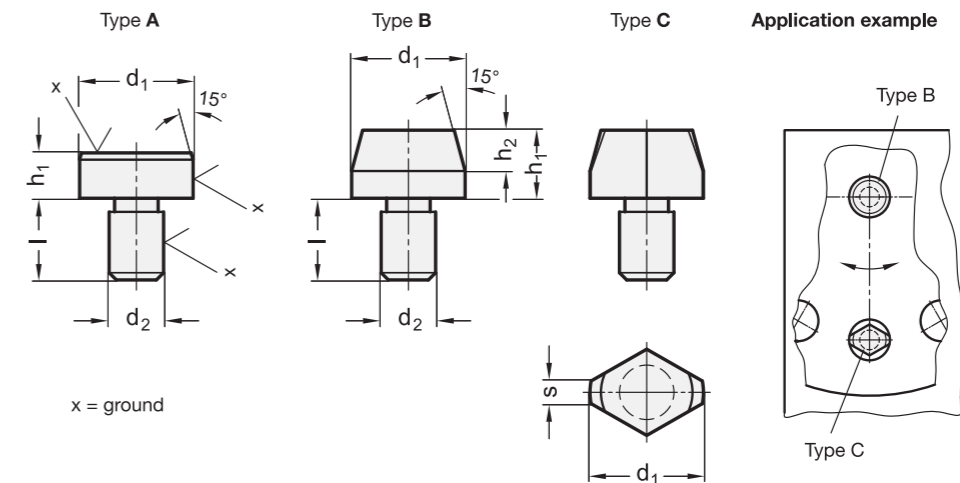

DIN 6321

Description	d1 g6	h1 h9	h1 ±0.1	d2 n6	h2	l	s ≈	⚖
DIN 6321-6-5-A	6	5	-	4	-	6	-	2
DIN 6321-10-6-A	10	6	-	6	-	9	-	5
DIN 6321-16-8-A	16	8	-	8	-	12	-	17
DIN 6321-25-10-A	25	10	-	12	-	18	-	53
DIN 6321-6-7-B	6	-	7	4	4	6	-	2
DIN 6321-6-12-B	6	-	12	4	4	6	-	3
DIN 6321-8-10-B	8	-	10	6	6	9	-	5
DIN 6321-8-16-B	8	-	16	6	6	9	-	7
DIN 6321-10-10-B	10	-	10	6	6	9	-	7
DIN 6321-10-18-B	10	-	18	6	6	9	-	12
DIN 6321-12-10-B	12	-	10	6	6	9	-	10
DIN 6321-12-18-B	12	-	18	6	6	9	-	17
DIN 6321-16-13-B	16	-	13	8	8	12	-	22
DIN 6321-16-22-B	16	-	22	8	8	12	-	36
DIN 6321-20-15-B	20	-	15	12	9	18	-	47
DIN 6321-20-25-B	20	-	25	12	9	18	-	72
DIN 6321-25-15-B	25	-	15	12	9	18	-	66
DIN 6321-25-25-B	25	-	25	12	9	18	-	105

DIN 6321

Description	d1 g6	h1 h9	h1 ±0.1	d2 n6	h2	l	s ≈	⚖
DIN 6321-6-7-C	6	-	7	4	4	6	1	1
DIN 6321-6-12-C	6	-	12	4	4	6	1	2
DIN 6321-8-10-C	8	-	10	6	6	9	1.6	4
DIN 6321-8-16-C	8	-	16	6	6	9	1.6	5
DIN 6321-10-10-C	10	-	10	6	6	9	2.5	6
DIN 6321-10-18-C	10	-	18	6	6	9	2.5	9
DIN 6321-12-10-C	12	-	10	6	6	9	2.5	7
DIN 6321-12-18-C	12	-	18	6	6	9	2.5	11
DIN 6321-16-13-C	16	-	13	8	8	12	3.5	17
DIN 6321-16-22-C	16	-	22	8	8	12	3.5	25
DIN 6321-20-15-C	20	-	15	12	9	18	5	39
DIN 6321-20-25-C	20	-	25	12	9	18	5	55
DIN 6321-25-15-C	25	-	15	12	9	18	5	49
DIN 6321-25-25-C	25	-	25	12	9	18	5	72