

EYE BOLTS AND NUTS

GN 1524

Swing bolts
Steel
Stainless Steel



page 1074

DIN 444

Eye bolts
Steel
Stainless Steel



page 1075

DIN 580

Lifting eye bolts
Steel



page 1076

DIN 580-NI

Lifting eye bolts
Stainless Steel



page 1076

DIN 580-A4

Lifting eye bolts
Stainless Steel



page 1076

DIN 582

Lifting eye nuts
Steel



page 1077

DIN 582-NI

Lifting eye nuts
Stainless Steel A2



page 1077

DIN 582-A4

Lifting eye nuts
Stainless Steel A4



page 1077

GN 581

Lifting eye bolts
(rotating)



page 1078

GN 581.5

Stainless Steel-Lifting
eye bolts (rotating)



page 1080

GN 583

Lifting eye nuts
(rotating)



page 1082

GN 5860

Load rings



page 1084

GN 5862

Load hooks



page 1086

GN 586.1

Load rings (rotating)



page 1088

GN 587

Load rings
for welding



page 1090

GN 589

Lifting points
for welding



page 1092

GN 584

Shackles
straight version



page 1094

GN 585

Shackles
cranked version



page 1095

GN 1130

Lifting pins
Steel



page 1096

GN 1130-NI

Lifting pins
Stainless Steel



page 1096

Swing bolts

Steel / Stainless Steel, with long threaded bolt

SPECIFICATION

Version in Steel

- Tensile strength class 5.8
- turned
- blackened

Version in Stainless Steel NI

- AISI 303
- turned
- matt shot-blasted

INFORMATION

Swing bolts GN 1524 offer a longer threaded bolt contrary to DIN 444 (see page 935).

For stocking purpose cylinder head shoulder bolts GN 732 (see page 919) can be used for the sizes M8, M10 and M12.

TECHNICAL INFORMATION

- ISO-Fundamental Tolerance (see page A21)
- Stainless Steel characteristics (see page A26)
- Strength values of screws (see page A20)

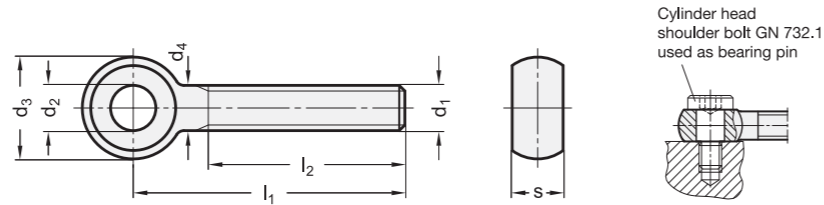

GN 1524

Description	d1	l1	l2	d2 E8	d3 -0.4	s -0.2	d4	⚖
GN 1524-M6-50	M 6	50	40	6	12	8	6	10
GN 1524-M6-60	M 6	60	40	6	12	8	6	15
GN 1524-M6-70	M 6	70	40	6	12	8	6	15
GN 1524-M6-80	M 6	80	40	6	12	8	6	20
GN 1524-M8-50	M 8	50	40	8	16	10	8	25
GN 1524-M8-60	M 8	60	45	8	16	10	8	25
GN 1524-M8-70	M 8	70	45	8	16	10	8	30
GN 1524-M8-80	M 8	80	45	8	16	10	8	35
GN 1524-M8-100	M 8	100	45	8	16	10	8	35
GN 1524-M10-50	M 10	50	38	10	20	12	10	35
GN 1524-M10-60	M 10	60	46	10	20	12	10	40
GN 1524-M10-70	M 10	70	50	10	20	12	10	45
GN 1524-M10-80	M 10	80	50	10	20	12	10	55
GN 1524-M10-100	M 10	100	50	10	20	12	10	66
GN 1524-M10-120	M 10	120	50	10	20	12	10	75
GN 1524-M12-50	M 12	50	35	12	25	14	12	60
GN 1524-M12-60	M 12	60	42	12	25	14	12	70
GN 1524-M12-70	M 12	70	52	12	25	14	12	75
GN 1524-M12-80	M 12	80	60	12	25	14	12	85
GN 1524-M12-100	M 12	100	60	12	25	14	12	100
GN 1524-M12-120	M 12	120	60	12	25	14	12	115
GN 1524-M12-130	M 12	130	60	12	25	14	12	125
GN 1524-M16-70	M 16	70	49	16	32	18	16	140
GN 1524-M16-80	M 16	80	59	16	32	18	16	158
GN 1524-M16-100	M 16	100	77	16	32	18	16	180
GN 1524-M16-120	M 16	120	80	16	32	18	16	210
GN 1524-M16-140	M 16	140	80	16	32	18	16	245
GN 1524-M16-160	M 16	160	80	16	32	18	16	275
GN 1524-M20-100	M 20	100	75	20	40	22	20	300
GN 1524-M20-120	M 20	120	95	20	40	22	20	346
GN 1524-M20-140	M 20	140	100	20	40	22	20	390
GN 1524-M20-160	M 20	160	100	20	40	22	20	438
GN 1524-M24-160	M 24	160	120	25	50	28	24	685
GN 1524-M24-240	M 24	240	120	25	50	28	24	965

GN 1524-NI

STAINLESS STEEL

Description	d1	l1	l2	d2 E8	d3 -0.4	s -0.2	d4	⚖
GN 1524-M6-50-NI	M 6	50	40	6	12	8	6	10
GN 1524-M6-60-NI	M 6	60	40	6	12	8	6	15
GN 1524-M6-70-NI	M 6	70	40	6	12	8	6	15
GN 1524-M6-80-NI	M 6	80	40	6	12	8	6	20
GN 1524-M8-50-NI	M 8	50	40	8	16	10	8	25
GN 1524-M8-60-NI	M 8	60	45	8	16	10	8	25
GN 1524-M8-70-NI	M 8	70	45	8	16	10	8	30
GN 1524-M8-80-NI	M 8	80	45	8	16	10	8	35
GN 1524-M8-100-NI	M 8	100	45	8	16	10	8	40
GN 1524-M10-50-NI	M 10	50	38	10	20	12	10	35
GN 1524-M10-60-NI	M 10	60	46	10	20	12	10	40
GN 1524-M10-70-NI	M 10	70	50	10	20	12	10	45
GN 1524-M10-80-NI	M 10	80	50	10	20	12	10	55
GN 1524-M10-100-NI	M 10	100	50	10	20	12	10	66
GN 1524-M10-120-NI	M 10	120	50	10	20	12	10	75
GN 1524-M12-50-NI	M 12	50	35	12	25	14	12	60
GN 1524-M12-60-NI	M 12	60	42	12	25	14	12	70
GN 1524-M12-70-NI	M 12	70	52	12	25	14	12	75
GN 1524-M12-80-NI	M 12	80	60	12	25	14	12	85
GN 1524-M12-100-NI	M 12	100	60	12	25	14	12	100
GN 1524-M12-120-NI	M 12	120	60	12	25	14	12	115
GN 1524-M12-130-NI	M 12	130	60	12	25	14	12	127
GN 1524-M16-70-NI	M 16	70	49	16	32	18	16	140
GN 1524-M16-80-NI	M 16	80	59	16	32	18	16	155
GN 1524-M16-100-NI	M 16	100	77	16	32	18	16	180
GN 1524-M16-120-NI	M 16	120	80	16	32	18	16	210
GN 1524-M16-140-NI	M 16	140	80	16	32	18	16	245
GN 1524-M16-160-NI	M 16	160	80	16	32	18	16	275
GN 1524-M20-100-NI	M 20	100	75	20	40	22	20	300
GN 1524-M20-120-NI	M 20	120	95	20	40	22	20	346
GN 1524-M20-140-NI	M 20	140	100	20	40	22	20	390
GN 1524-M20-160-NI	M 20	160	100	20	40	22	20	438

Eye Screws

DIN 444

from Steel resp. Stainless Steel

INOX

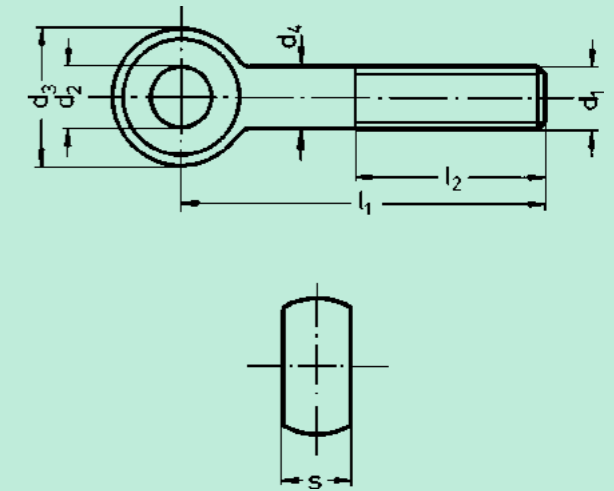

In precise design finished. Mainly used for jigs and fixtures.

Different from the specified standard, the eye screw have stability class 5.8 (instead of 4.6/5.6) and a larger thread length l_2 .

Model: Steel 5.8, black oxide finished resp. stainless steel 1.4305, sand-blasted matt. Thread rolled. Eye screws M 12, M 16, M 20 from steel 5.8 can also be supplied at more reasonable prices in finish N Screw/Eye butt welded, weld turned.

Eye Screws DIN 444

Order No. Steel	Order No. Stainless Steel	l1 mm	Thread d1	l2 mm	d2 H7	d3 -0,3 mm	s -0,15 mm	d4 mm
54 050 06	54 050 06 E0A	50	M 6	32	6	14	7	6
54 075 06	54 075 06 E0A	75	M 6					
54 050 08	54 050 08 E0A	50	M 8	32	8	18	9	8
54 075 08	54 075 08 E0A	75	M 8					
54 075 10	54 075 10 E0A	75	M 10	40	10	20	12	10
54 100 10	54 100 10 E0A	100	M 10					
54 100 12	54 100 12 E0A	100	M 12	40	12	25	14	12
54 130 12	54 130 12 E0A	130	M 12					
54 100 16	54 100 16 E0A	100	M 16	50	16	32	17	16
54 130 16	54 130 16 E0A	130	M 16					

Eye Screws DIN 444 - Type B

Zimmermann Eye Screws, Type B in the usual model DIN 444 at more reasonable prices are available on request.

Lifting eye bolts

Steel / Stainless Steel

SPECIFICATION

Version in Steel ST

- Steel C 15 E
- drop-forged
- annealed
- contact face machined
- zinc plated, blue passivated

Version in Stainless Steel A2 NI

- drop-forged
- contact face machined

Version in Stainless Steel A4

- drop-forged
- contact face machined

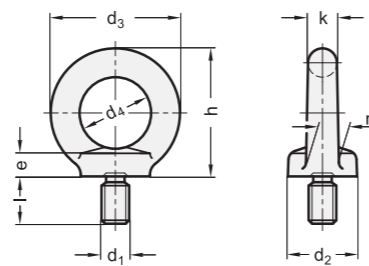

INFORMATION

The following guidelines for lifting eye bolts DIN 580 have to be observed in addition to the load values given in the above table:
The eye bolt must be of fully screwed in to achieve a perfect contact between the two mating faces.
Both threads must be of a equal length and the base material of equal strength to that of the bolt.
Operating instructions with more details and specifications are included with every delivery.
The official DIN standard sheet specifies the additional sizes M42, M48, M56, M64, M72 x 6, M80 x 6 and M100 x 6.

TECHNICAL INFORMATION

- Stainless Steel characteristics (see page A26)

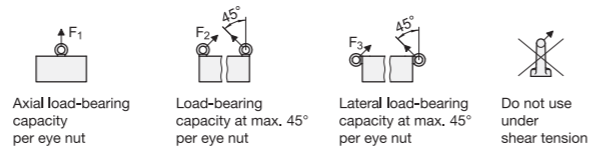

DIN 580

Description	d1	d2	d3	d4	e	h	k	l	m	F1 max. in N	F2 max. in N	F3 max. in N	⚖️
DIN 580-M8-ST	M 8	20	36	20	6	36	8	13	10	1400	1000	700	60
DIN 580-M10-ST	M 10	25	45	25	8	45	10	17	12	2300	1700	1150	102
DIN 580-M12-ST	M 12	30	54	30	10	53	12	20.5	14	3400	2400	1700	180
DIN 580-M16-ST	M 16	35	63	35	12	62	14	27	16	7000	5000	3500	280
DIN 580-M20-ST	M 20	40	72	40	14	71	16	30	19	12000	8600	6000	450
DIN 580-M24-ST	M 24	50	90	50	18	90	20	36	24	18000	12900	9000	900
DIN 580-M30-ST	M 30	65	108	60	22	109	24	45	28	32000	23000	16000	1600
DIN 580-M36-ST	M 36	75	126	70	26	128	28	54	32	46000	33000	23000	2400

DIN 580-NI

STAINLESS STEEL

Description	d1	d2	d3	d4	e	h	k	l	m	F1 max. in N	F2 max. in N	F3 max. in N	⚖️
DIN 580-M8-NI	M 8	20	36	20	6	36	8	13	10	1400	1000	700	55
DIN 580-M10-NI	M 10	25	45	25	8	45	10	17	12	2300	1700	1150	120
DIN 580-M12-NI	M 12	30	54	30	10	53	12	20.5	14	3400	2400	1700	160
DIN 580-M16-NI	M 16	35	63	35	12	62	14	27	16	7000	5000	3500	300
DIN 580-M20-NI	M 20	40	72	40	14	71	16	30	19	12000	8600	6000	450
DIN 580-M24-NI	M 24	50	90	50	18	90	20	36	24	18000	12900	9000	840

DIN 580-A4

STAINLESS STEEL

Description	d1	d2	d3	d4	e	h	k	l	m	F1 max. in N	F2 max. in N	F3 max. in N	⚖️
DIN 580-M10-A4	M 10	25	45	25	8	45	10	17	12	2300	1700	1150	102
DIN 580-M12-A4	M 12	30	54	30	10	53	12	20.5	14	3400	2400	1700	172
DIN 580-M16-A4	M 16	35	63	35	12	62	14	27	16	7000	5000	3500	312
DIN 580-M20-A4	M 20	40	72	40	14	71	16	30	19	12000	8600	6000	439
DIN 580-M24-A4	M 24	50	90	50	18	90	20	36	24	18000	12900	9000	918

Lifting eye nuts

Steel / Stainless Steel

SPECIFICATION

Version in Steel ST

- Steel C 15 E
- drop-forged
- annealed
- contact face machined
- zinc plated, blue passivated

Version in Stainless Steel A2 NI

- drop-forged
- contact face machined

Version in Stainless Steel A4

- drop-forged
- contact face machined

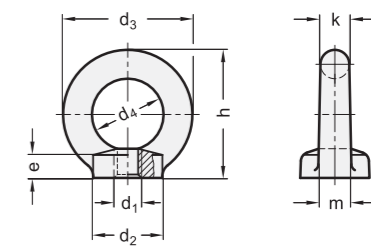

INFORMATION

The following guidelines of the lifting eye nuts DIN 582 have to be observed in addition to the load values given in the above table:
The eye nut must be of fully screwed in to achieve a perfect contact between the two mating faces.
Both threads must be of a equal length and the base material of equal strength to that of the nut.
Operating instructions with more details and specifications are included with every delivery.
The official DIN standard sheet specifies the additional sizes M42, M48, M56, M64, M72 x 6, M80 x 6 and M100 x 6.

TECHNICAL INFORMATION

- Stainless Steel characteristics (see page A26)

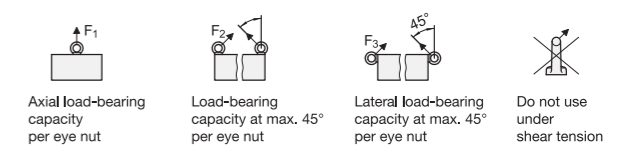

DIN 582

Description	d1	d2	d3	d4	e	h	k	m	F1 max. in N	F2 max. in N	F3 max. in N	⚖️
DIN 582-M8-ST	M 8	20	36	20	8.5	36	8	10	1400	1000	700	50
DIN 582-M10-ST	M 10	25	45	25	10	45	10	12	2300	1700	1150	100
DIN 582-M12-ST	M 12	30	54	30	11	53	12	14	3400	2400	1700	155
DIN 582-M16-ST	M 16	35	63	35	13	62	14	16	7000	5000	3500	220
DIN 582-M20-ST	M 20	40	72	40	16	71	16	19	12000	8600	6000	360
DIN 582-M24-ST	M 24	50	90	50	20	90	20	24	18000	12900	9000	720
DIN 582-M30-ST	M 30	65	108	60	25	109	24	28	32000	23000	16000	1320
DIN 582-M36-ST	M 36	75	126	70	30	128	28	32	46000	33000	23000	2130

DIN 582-NI

STAINLESS STEEL

Description	d1	d2	d3	d4	e	h	k	m	F1 max. in N	F2 max. in N	F3 max. in N	⚖️
DIN 582-M8-NI	M 8	20	36	20	8.5	36	8	10	1400	1000	700	50
DIN 582-M10-NI	M 10	25	45	25	10	45	10	12	2300	1700	1150	100
DIN 582-M12-NI	M 12	30	54	30	11	53	12	14	3400	2400	1700	160
DIN 582-M16-NI	M 16	35	63	35	13	62	14	16	7000	5000	3500	240
DIN 582-M20-NI	M 20	40	72	40	16	71	16	19	12000	8600	6000	340
DIN 582-M24-NI	M 24	50	90	50	20	90	20	24	18000	12900	9000	650

DIN 582-A4

STAINLESS STEEL

Description	d1	d2	d3	d4	e	h	k	m	F1 max. in N	F2 max. in N	F3 max. in N	⚖️
DIN 582-M10-A4	M 10	25	45	25	10	45	10	12	2300	1700	1150	88
DIN 582-M12-A4	M 12	30	54	30	11	53	12	14	3400	2400	1700	167
DIN 582-M16-A4	M 16	35	63	35	13	62	14	16	7000	5000	3500	249
DIN 582-M20-A4	M 20	40	72	40	16	71	16	19	12000	8600	6000	380
DIN 582-M24-A4	M 24	50	90	50	20	90	20	24	18000	12900	9000	753

Lifting eye bolts (rotating)

SPECIFICATION

Types

- Type **A**: without spanner
- Type **B**: with spanner

Ring

Steel, German Material No. 1.6541

- forged
- high-tensile tempered
- 100 % electro magnetic tensile tested to EN 1677
- plastic coated, pink

Bolt

Steel
Tensile strength class 10.9
100 % electro magnetic tensile tested

INFORMATION

The lifting eye bolts GN 581 are mounted in rotating bearings, allowing the direction of the force action to be adjusted and preventing inadvertent loosening or overturning (as potentially possible in lifting eye bolts DIN 580, see page 1076).

Lifting eye bolts GN 581 offer a high load carrying capacity and they are tested to meet safety standards (safety factor 4).

The rated load carrying capacity listed in the above table is clearly marked on the ring. It applies to the most unfavourable load application of the load types listed opposite.

Lifting eye bolts GN 581 comply with Mechanical Engineering Directive 2006 / 42 / EG and are BG tested.

The integrated RFID transponder clearly marks and identifies the sling and lifting gear, e.g. during the prescribed regular inspection.

The hexagon socket bolt cannot be removed from the ring.

Type B is suitable for assembly without the need to use tools: inserting the spanner in the hexagon socket of the bolt allows the bolt to be turned in and out by hand.

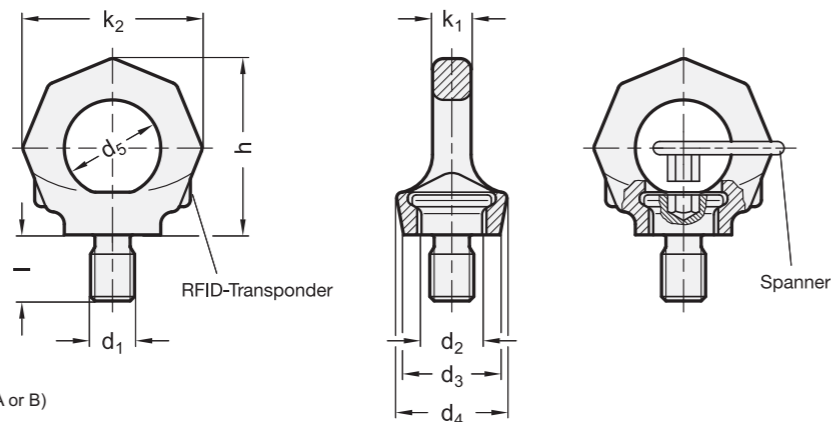

*Complete with type index of the Lifting eye bolts (A or B)

A without spanner **B** with spanner

GN 581

Description	d1	d2	d3	d4	d5	h	k1	k2	l	Nominal load (WLL)	Δ
GN 581-M6-*	M 6	13	23	28	20	37	7	37	9	0.1 t [1.0 kN]	100
GN 581-M8-*	M 8	16	25	30	25	46	9	47	12	0.3 t [3.0 kN]	120
GN 581-M10-*	M 10	16	25	30	25	46	9	47	15	0.4 t [4.0 kN]	120
GN 581-M12-*	M 12	20	30	34	30	55	10	56	18	0.75 t [7.5 kN]	180
GN 581-M16-*	M 16	23.5	36	40	35	64	13	65	24	1.5 t [15.0 kN]	320
GN 581-M20-*	M 20	29	41	50	40	75	16	76	30	2.3 t [23.0 kN]	490
GN 581-M24-*	M 24	35	51	60	49	90	19	92	36	3.2 t [32.0 kN]	900
GN 581-M30-*	M 30	44	66	75	60	113	24	114	45	4.5 t [45.0 kN]	1650
GN 581-M36-*	M 36	53	75	90	72	135	29	135	54	7.0 t [70.0 kN]	3100

Weight A



Method of mounting										
Number	1	1	2	2	2	2	2	3 and 4	3 and 4	3 and 4
Angles of inclination	0°	90°	0°	90°	0° to 45°	45° to 60°	asymm.	0° to 45°	45° to 60°	asymm.
Factor	1	1	2	2	1.4	1	1	2.1	1.5	1
M 6	0.50	0.10 t	1.00	0.20 t	0.14	0.10 t	0.10 t	0.21 t	0.15 t	0.10 t
M 8	1.00 [0.14]	0.30 t	2.00 [0.28]	0.60 t	0.42 [0.10]	0.30 t	0.30 t	0.63 t	0.45 t	0.30 t
M 10	1.00 t [0.23]	0.40 t	2.00 [0.46]	0.80 t	0.56 [0.17]	0.40 t	0.40 t	0.84 t	0.60 t	0.40 t
M 12	2.00 [0.34]	0.75 t	4.00 [0.68]	1.50 t	1.00 [0.24]	0.75 t	0.75 t	1.60 t	1.12 t	0.75 t
M 16	4.00 [0.70]	1.50 t	8.00 [1.40]	3.00 t	2.10 [0.50]	1.50 t	1.50 t	3.15 t	2.25 t	1.50 t
M 20	6.00 [1.20]	2.30 t	12.00 [2.40]	4.60 t	3.22 [0.86]	2.30 t	2.30 t	4.83 t	3.45 t	2.30 t
M 24	8.00 [1.80]	3.20 t	16.00 [3.60]	6.40 t	4.48 [1.29]	3.20 t	3.20 t	6.70 t	4.80 t	3.20 t
M 30	12.00 [3.20]	4.50 t	24.00 [6.40]	9.00 t	6.30 [2.30]	4.50 t	4.50 t	9.40 t	6.70 t	4.50 t
M 36	16.0 [4.60]	7.00 t	32.00 [9.20]	14.00 t	9.80 [3.30]	7.00 t	7.00 t	14.70 t	10.50 t	7.00 t

SAFETY INSTRUCTIONS

The loads given in brackets refer to the load capacity of the corresponding lifting eye bolt DIN 580. If such a value is not indicated the use of the lifting eye bolts DIN 580 is not permitted!

The bolt-on surface for the lifting eye bolts GN 581 must be plane and at a right angle to the threaded borehole; the countersinking must be ≤ the nominal diameter of the thread.

Screwed in, the collar of the screw must make firm contact (do not use washers) and the eye bolt must rotate freely by 360°.

Before applying the load, turn the lifting eye bolt in the direction of the force. The lifting eye bolt is not suitable for frequent rotation cycles under load.

The specified load values apply for a minimum screw-in length of 1.5 × nominal thread diameter in steel with a minimum tensile strength of 37 kp/mm², at an ambient temperature of - 40° C to + 280° C. Load-bearing capacity under different conditions upon request. Operating instructions with more details and specifications are included with every delivery (see also www.elesa-ganter.com).

Stainless Steel-Lifting eye bolts (rotating)

SPECIFICATION

Ring
Stainless Steel

- German Material No. 1.4462
- forged
- 100 % electro magnetic tensile tested to EN 1677
- blank

Bolt
Stainless Steel
German Material 1.4462

INFORMATION

Stainless Steel-Lifting eye bolts GN 581.5 are mounted in rotating bearings, allowing the direction of the force action to be adjusted and preventing inadvertent loosening or overturning (as potentially possible in Stainless Steel-Lifting eye bolts DIN 580 (see page 1076). Stainless Steel-Lifting eye bolts GN 581.5 offer a high load carrying capacity and they are tested to meet safety standards (safety factor 4). The rated load carrying capacity listed in the above table is clearly marked on the ring. It applies to the most unfavourable load application of the load types listed opposite.

Stainless Steel-Lifting eye bolts GN 581.5 eye bolts comply with Mechanical Engineering Directive 2006 / 42 / EG and are BG tested. The integrated RFID transponder clearly marks and identifies the sling and lifting gear, e.g. during the prescribed regular inspection. The hexagon socket bolt cannot be removed from the ring.

TECHNICAL INFORMATION

- Stainless Steel characteristics (see page A26)

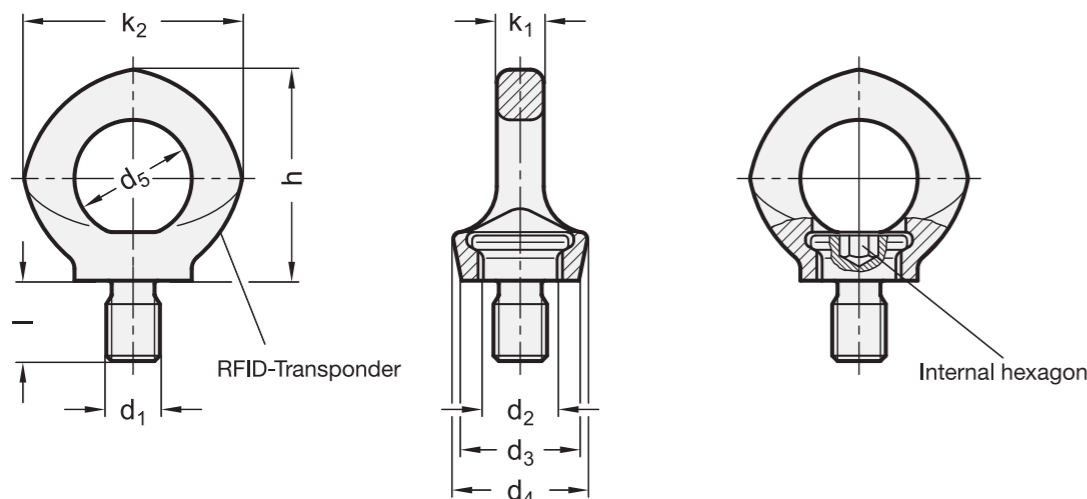

GN 581.5

STAINLESS STEEL

Description	d1	d2	d3	d4	d5	h	k1	k2	l	Nominal load (WLL)	Δ
GN 581.5-M12	M 12	18	30	32	30	57	12	56	18	0.5 t [5 kN]	200
GN 581.5-M16	M 16	22	35.5	38	35	66	14	65	24	1.0 t [10 kN]	333
GN 581.5-M20	M 20	27.5	41.5	47	40	76	16	74	30	2.0 t [20 kN]	520
GN 581.5-M24	M 24	33	50	56	48	94	19	92	35	2.5 t [25 kN]	912

Method of mounting									
Number	1	1	2	2	2	2	2	3 and 4	3 and 4
Angles of inclination	0°	90°	0°	90°	0° to 45°	45° to 60°	asymm.	0° to 45°	45° to 60°
Factor	1	1	2	2	1.4	1	1	2.1	1.5
M 12	1.20 [0.34]	0.50 t	2.40 [0.68]	1.00 t	0.70 [0.24]	0.50 t	0.50 t	1.06 t	0.75 t
M 16	2.40 [0.70]	1.00 t	4.80 [1.40]	2.00 t	1.42 [0.50]	1.00 t	1.00 t	2.12 t	1.50 t
M 20	3.60 [1.20]	2.00 t	7.20 [2.40]	4.00 t	2.83 [0.86]	2.00 t	2.00 t	4.24 t	3.00 t
M 24	5.20 [1.80]	2.50 t	10.40 [3.60]	5.00 t	3.53 [1.29]	2.50 t	2.50 t	5.30 t	3.75 t

SAFETY INSTRUCTIONS

The loads given in brackets refer to the load capacity of the corresponding lifting eye bolt DIN 580. If such a value is not indicated the use of the lifting eye bolts DIN 580 is not permitted!

The bolt-on surface for the Stainless Steel-Lifting eye bolts GN 581.5 must be plane and at a right angle to the threaded borehole; the countersinking must be \leq the nominal diameter of the thread.

Screwed in, the collar of the screw must make firm contact (do not use washers) and the eye bolt must rotate freely by 360°.

Before applying the load, turn the lifting eye bolt in the direction of the force. The lifting eye bolt is not suitable for frequent rotation cycles under load.

The specified load values apply for a minimum screw-in length of $1.5 \times$ nominal thread diameter in steel with a minimum tensile strength of 37 kp/mm², at an ambient temperature of - 40° C to + 280° C. Load-bearing capacity under different conditions upon request.

Lifting eye nuts (rotating)

SPECIFICATION

Ring

- Steel, German Material No. 1.6541
- high-tensile tempered
- forged
- 100 % electro magnetic tensile tested to EN 1677
- plastic coated, pink

Nut

Steel

Tensile strength class 10 (1000 N/mm²)

INFORMATION

Lifting eye nuts GN 583 are mounted in rotating bearings, allowing the direction of the force action to be adjusted and preventing inadvertent loosening or overturning (as potentially possible in lifting eye nuts DIN 582 (see page 1077)).

Lifting eye nuts GN 583 offer a high load carrying capacity and they are tested to meet safety standards (safety factor 4).

The rated load carrying capacity listed in the above table is clearly marked on the ring. It applies to the most unfavourable load application of the load types listed opposite.

Lifting eye nuts GN 583 comply with Mechanical Engineering Directive 2006 / 42 / EG and are BG tested.

The integrated RFID transponder clearly marks and identifies the sling and lifting gear, e.g. during the prescribed regular inspection.

The hexagon socket nut cannot be removed from the ring.

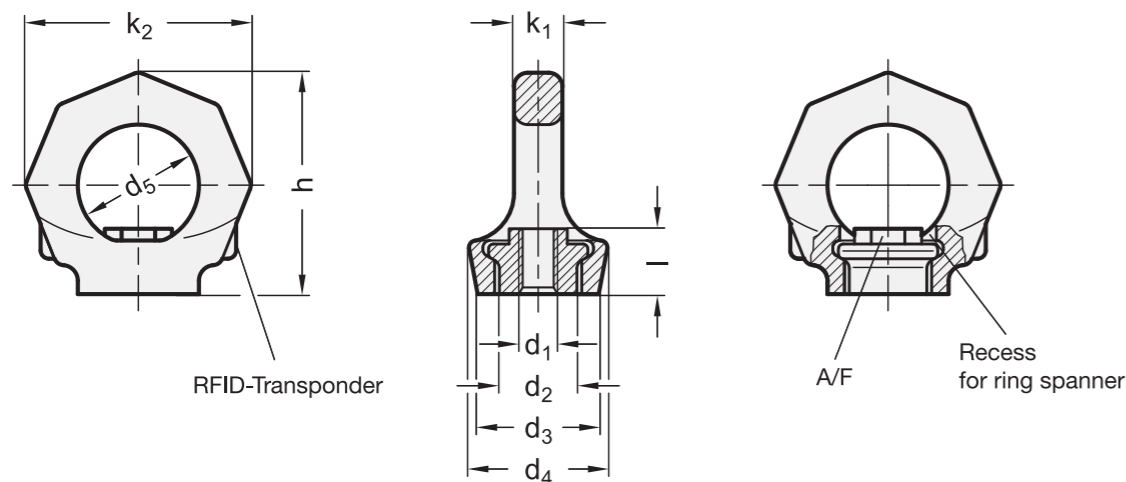

GN 583

Description	d1	d2	d3	d4	d5	h	k1	k2	l	A/F	Nominal load (WLL)	⚖️
GN 583-M8	M 8	16	25	28	25	45	8.5	47	14	12	0.3 t [3 kN]	101
GN 583-M10	M 10	16	25	28	25	45	8.5	47	14	12	0.4 t [4 kN]	110
GN 583-M12	M 12	20	30	34	30	55	10	56	17	14	0.75 t [7.5 kN]	160
GN 583-M16	M 16	22	35.5	40	35	66	14	65	21	19	1.5 t [15 kN]	300
GN 583-M20	M 20	29	40	50	40	74	16	75	23	24	2.3 t [23 kN]	420
GN 583-M24	M 24	35	50	60	48	90	19	90	29	30	3.2 t [32 kN]	770
GN 583-M30	M 30	44	60	75	60	112	24	112	34	36	4.5 t [45 kN]	1480

Method of mounting										
Number	1	1	2	2	2	2	2	3 and 4	3 and 4	3 and 4
Angles of inclination	0°	90°	0°	90°	0° to 45°	45° to 60°	asymm.	0° to 45°	45° to 60°	asymm.
Factor	1	1	2	2	1.4	1	1	2.1	1.5	1
M 8	1.00 [0.14]	0.30 t	2.00 [0.28]	0.60 t	0.42 [0.10]	0.30 t	0.30 t	0.63 t	0.45 t	0.30 t
M 10	1.00 [0.23]	0.40 t	2.00 [0.46]	0.80 t	0.56 [0.17]	0.40 t	0.40 t	0.84 t	0.60 t	0.40 t
M 12	2.00 [0.34]	0.75 t	4.00 [0.68]	1.50 t	1.00 [0.24]	0.75 t	0.75 t	1.60 t	1.12 t	0.75 t
M 16	4.00 [0.70]	1.50 t	8.00 [1.40]	3.00 t	2.10 [0.50]	1.50 t	1.50 t	3.15 t	2.25 t	1.50 t
M 20	6.00 [1.20]	2.30 t	12.00 [2.40]	4.60 t	3.22 [0.86]	2.30 t	2.30 t	4.83 t	3.45 t	2.30 t
M 24	8.00 [1.80]	3.20 t	16.00 [3.60]	6.40 t	4.48 [1.29]	3.20 t	3.20 t	6.70 t	4.80 t	3.20 t
M 30	12.00 [3.20]	4.50 t	24.00 [6.40]	9.00 t	6.30 [2.30]	4.50 t	4.50 t	9.40 t	6.70 t	4.50 t

SAFETY INSTRUCTIONS

The loads given in brackets refer to the load capacity of the corresponding lifting eye nut DIN 582. If such a value is not indicated the use of the lifting eye nuts DIN 582 is not permitted!

The bolt-on surface for the lifting eye nuts GN 583 must be plane and at a right angle to the threaded borehole. Screwed in, the collar of the nut must make firm contact (do not use washers) and the eye nut must rotate freely by 360°.

Before applying the load, turn the lifting eye nut in the direction of the force. The lifting eye nut is not suitable for frequent rotation cycles under load.

The specified load values apply only in connection with threaded bolts of steel grade > 10.9 if the bolt is turned in over its entire length l. These load values also apply only for a minimum screw-in length of 1.5 × nominal thread diameter in steel with a minimum tensile strength of 37 kp/mm², at an ambient temperature of - 40 °C to + 100 °C.

Load-bearing capacity under different conditions upon request.

Operating instructions with more details and specifications are included with every delivery.

Load rings

SPECIFICATION

Chain ring
Steel, German Material No. 1.6540
- high-tensile tempered
- 100% electro magnetic tensile tested to EN 1677
- plastic coated, pink

Eye ring
Steel, German Material No. 1.6541
- forged
- high-tensile tempered
- 100 % electro magnetic tensile tested
- plastic coated, pink

Bearing case
Steel, German Material No. 1.6541
- forged
- high-tensile tempered
- 100 % electro magnetic tensile tested
- zinc plated, blue passivated

Screw
Steel
Tensile strength class 10.9 (1000 N/mm²)
Finish: Delta Tone



INFORMATION

Load rings GN 5860 rotate running in ball bearings. The freely rotating ring allows the bolts to hold loads in any tensile direction. The rated load-bearing capacity is shown clearly on the swivel eye bolt. It is valid for the most unfavourable case in term of the types of load listed opposite. Load rings GN 5860 comply with Mechanical Engineering Directive 2006 / 42 / EG and are BG tested. The integrated RFID transponder clearly marks and identifies the sling and lifting gear, e.g. during the prescribed regular inspection.

ON REQUEST

- other screw length l

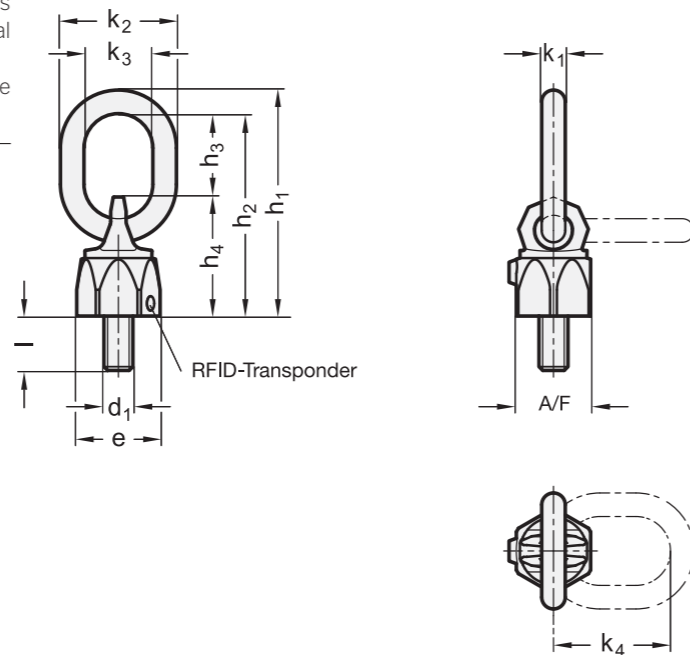

GN 5860

Description	d1	l	e	h1	h2	h3	h4	k1	k2	k3	k4	A/F	Tightening torque in Nm	Nominal load in t	Δ
GN 5860-M8-13	M 8	13	30	84	76	31	45	8	45	29	44	28	10	0.30	175
GN 5860-M10-17	M 10	17	36	86	78	31	47	8	45	29	44	30	10	0.45	205
GN 5860-M12-21	M 12	21	42	117	107	49	58	10	58	35	65	36	10	0.60	400
GN 5860-M16-25	M 16	25	48	126	113	46	67	13	64	38	65	41	30	1.30	664
GN 5860-M20-33	M 20	33	62	150	137	54	83	13	61	35	77	55	70	2.00	1294
GN 5860-M24-40	M 24	40	81	191	173	66	107	18	76	40	94	70	150	3.50	2647
GN 5860-M30-50	M 30	50	99	243	221	90	131	22	94	50	126	85	225	5.00	4950



Method of mounting									
Number	1	1	2	2	2	2	2	3 and 4	3 and 4
Angles of inclination	0°	90°	0°	90°	0° to 45°	45° to 60°	asymm.	0° to 45°	45° to 60°
Factor	1	1	2	2	1.4	1	1	2.1	1.5
M 8	0.60 t	0.30 t	1.20 t	0.60 t	0.42 t	0.30 t	0.30 t	0.63 t	0.45 t
M 10	0.90 t	0.45 t	1.80 t	0.90 t	0.63 t	0.45 t	0.45 t	0.94 t	0.67 t
M 12	1.20 t	0.60 t	2.40 t	1.20 t	0.84 t	0.60 t	0.60 t	1.26 t	0.90 t
M 16	2.60 t	1.30 t	5.20 t	2.60 t	1.81 t	1.30 t	1.30 t	2.73 t	1.95 t
M 20	4.00 t	2.00 t	8.00 t	4.00 t	2.80 t	2.00 t	2.00 t	4.20 t	3.00 t
M 24	7.00 t	3.50 t	14.00 t	7.00 t	4.90 t	3.50 t	3.50 t	7.35 t	5.25 t
M 30	10.00 t	5.00 t	20.00 t	10.00 t	7.00 t	5.00 t	5.00 t	10.50 t	7.50 t

SAFETY INSTRUCTIONS

The above load capacity table shows the maximum loads in metric tonnes as factor of the load ring type and at an operating temperature range of -40 °C to +100 °C, with a safety coefficient of 4 taken into account for all values.

The load ring GN 5860 may be used only if it is bolted with the minimum screw-in depth which depends on the material and if the bolt contact surface is plane and fixed at a right angle to the tap hole. If permanently mounted in place, the swivel eye bolt must rotate freely by 360° and must not rest on edges or other fixture, e.g. crane hooks. The load rings are not suitable for permanent rotary movement under load exposure. Operating instructions with more details and specifications are included with every delivery (see www.elesa-ganter.com).

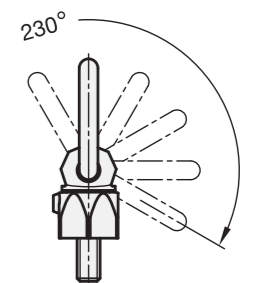

Load hooks

SPECIFICATION

Hook
Steel, German Material No. 1.6540
- high-tensile tempered
- 100% electro magnetic tensile tested to EN 1677
- plastic coated, pink

Safety catch
Steel, German Material No. 1.6541
- forged, high-tensile tempered
- 100 % electro magnetic tensile tested

Bearing case
Steel 1.6541
- forged, high-tensile tempered
- 100 % electro magnetic tensile tested
- zinc plated, blue passivated

Threaded stud
Steel, high-tensile tempered
Finish: Delta Tone

INFORMATION

Load hooks GN 5862 rotate running in ball bearings. The freely rotating hook allows the bolts to hold loads in any allowed tensile direction.
The rated load-bearing capacity is shown clearly on the swivel eye bolt. It is valid for the most unfavourable case in term of the types of load listed opposite. Load rings GN 5862 comply with Mechanical Engineering Directive 2006 / 42 / EG and are BG tested.
The integrated RFID transponder clearly marks and identifies the sling and lifting gear, e.g. during the prescribed regular inspection.

TECHNICAL INFORMATION

- Strength values of screws (see page A20)

ON REQUEST

- other screw lengths l

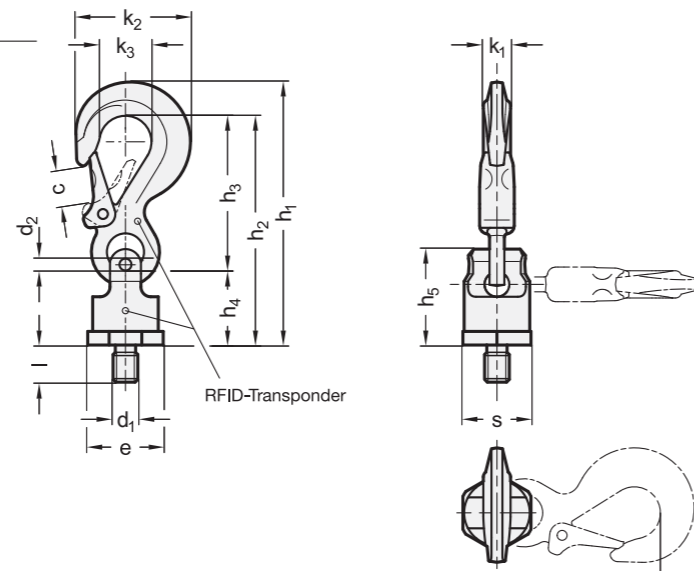

GN 5862

Description	d1	d2	l	e	h1	h2	h3	h4	h5	k1	k2	k3	k4	c	s	Tightening torque in Nm	Nominal load in t	⚖️
GN 5862-M12-18	M 12	4.8	18	40	129	116	75	41	49	12	52	25	82	18	36	10	0.63	400
GN 5862-M16-24	M 16	7.4	24	46	167	147	97	50	63	16	73	32	105	25	41	30	1.50	820
GN 5862-M20-30	M 20	9.6	30	61	215	187	126	61	78	20	95	42	136	30	55	70	2.50	1200
GN 5862-M24-36	M 24	12.1	36	87	263	227	150	77	96	26	118	52	163	35	70	150	4.00	1600
GN 5862-M30-45	M 30	15.6	45	95	304	267	174	93	119	30	135	57	189	40	85	225	5.00	2400
GN 5862-M36-54	M 36	19	54	100	356	310	208	102	137	36	161	68	227	48	90	410	8.00	3200



Method of mounting										
Number	1	1	2	2	2	2	2	3 and 4	3 and 4	3 and 4
Angles of inclination	0°	90°	0°	90°	0° to 45°	45° to 60°	asymm.	0° to 45°	45° to 60°	asymm.
Factor	1	1	2	2	1.4	1	1	2.1	1.5	1
M 12	0.63 t	0.63 t	1.26 t	1.26 t	0.88 t	0.63 t	0.63 t	1.32 t	0.95 t	0.63 t
M 16	1.50 t	1.50 t	3.00 t	3.00 t	2.10 t	1.50 t	1.50 t	3.15 t	2.25 t	1.50 t
M 20	2.50 t	2.50 t	5.00 t	5.00 t	3.50 t	2.50 t	2.50 t	5.25 t	3.75 t	2.50 t
M 24	4.00 t	4.00 t	8.00 t	8.00 t	5.60 t	4.00 t	4.00 t	8.40 t	6.00 t	4.00 t
M 30	6.70 t	5.00 t	13.40 t	10.00 t	7.00 t	5.00 t	5.00 t	10.50 t	7.50 t	5.00 t
M 36	10.00 t	8.00 t	20.00 t	16.00 t	11.20 t	8.00 t	8.00 t	16.80 t	12.00 t	8.00 t

SAFETY INSTRUCTIONS

The above load capacity table shows the maximum loads in metric tonnes as factor of the load ring type and at an operating temperature range of -40 °C to +200 °C, with a safety coefficient of 4 taken into account for all values.
The load hooks GN 5862 may be used only if it is bolted with the minimum screw-in depth which depends on the material and if the bolt contact surface is plane and fixed at a right angle to the tap hole.
If permanently mounted in place, the load hooks must rotate freely by 360° and must not rest on edges or other fixture, e.g. crane hooks. The load hooks are not suitable for permanent rotary movement under load exposure.
Operating instructions with more details and specifications are included with every delivery (see www.elesa-ganter.com)

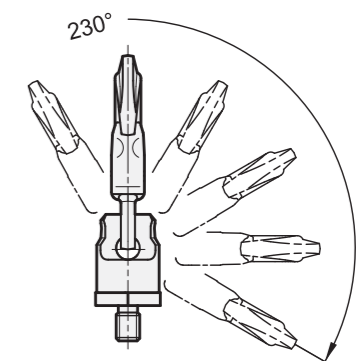

Load rings (rotating)

SPECIFICATION

Load rings
Steel, German Material No. 1.6541
- forged
- high-tensile tempered
- 100 % electro magnetic tensile tested to EN 1677
- plastic coated, pink

Fixing holder
- forged
- high-tensile tempered
- 100 % electro magnetic tensile tested
- plastic coated, pink

Bolt
Steel,
Tensile strength class 10.9 (1000 N/mm²)
Finish: Delta Tone

Bushing
Steel
galvanic zinc plated

INFORMATION

The load rings GN 586.1 can be folded and rotated into all approved directions, carrying the full load in any tension direction. They offer a high load carrying capacity and they are tested to meet safety standards (safety factor 4). The rated load carrying capacity listed in the table is clearly marked on the attachment bolt. It applies to the most unfavourable load application of the load types listed opposite. Load rings GN 586.1 comply with Mechanical Engineering Directive 2006 / 42 / EG and are BG tested. The integrated RFID transponder clearly marks and identifies the sling and lifting gear, e.g. during the prescribed regular inspection. This standard replaces the previous load rings GN 586.

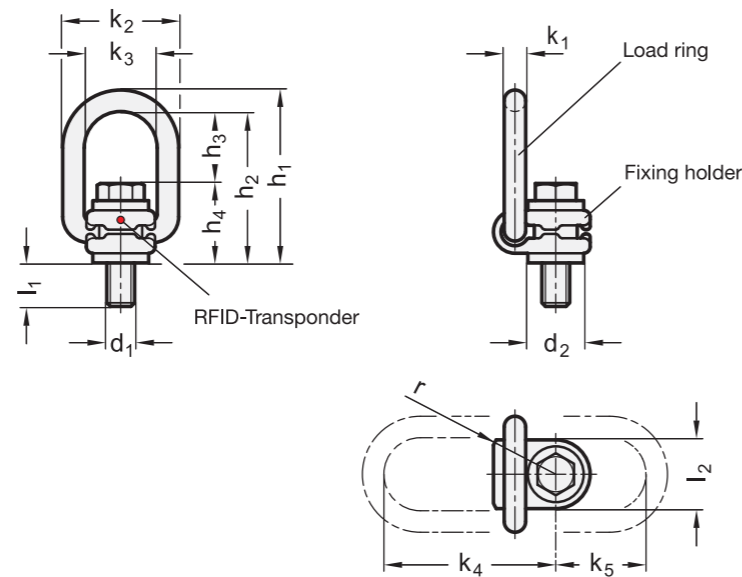

GN 586.1

Description	d1	d2	h1	h2	h3	h4	k1	k2	k3	k4	k5	l1	l2	r	A/F1	A/F2	Tightening torque in Nm	Nominal load in t (WLL)	Δ
GN 586.1-M8	M 8	24	87	75	40	35	12	54	34	75	45	11	30	32	13	5	30	0.3	300
GN 586.1-M10	M 10	24	87	75	39	36	12	54	34	75	45	15	30	32	17	6	60	0.63	300
GN 586.1-M12	M 12	26	87	75	38	37	12	54	34	75	45	18	32	32	19	8	100	1	326
GN 586.1-M16	M 16	30	99	85	39	46	13.5	56	36	86	47	22	33	38	24	10	150	1.5	500
GN 586.1-M20	M 20	45	127	110	55	55	16.5	82	54	113	64	32	50	48	30	12	250	2.5	1200
GN 586.1-M24	M 24	45	143	125	67	58	18	82	54	130	78	37	50	48	36	14	400	4	1320
GN 586.1-M30	M 30	60	170	147	67	80	22.5	103	65	151	80	49	60	67	46	17	500	5	3000



RUD



Method of mounting	G ₁	G ₂	2xG ₁	2xG ₂	G ₂	G ₂	G ₂	G ₂	G ₂	
Number	1	1	2	2	2	2	3 and 4	3 and 4	3 and 4	
Angles of inclination	0°	90°	0°	90°	0° to 45°	45° to 60°	asymm.	0° to 45°	45° to 60°	asymm.
Factor	1	1	2	2	1.4	1	1	2.1	1.5	1
M 8	0.63 t	0.63 t	1.26 t	1.26 t	0.88 t	0.63 t	0.63 t	1.26 t	0.94 t	0.63 t
M 10	0.90 t	0.90 t	1.80 t	1.80 t	1.26 t	0.90 t	0.90 t	1.90 t	1.35 t	0.90 t
M 12	1.35 t	1.35 t	2.70 t	2.70 t	1.90 t	1.35 t	1.35 t	2.80 t	2.00 t	1.35 t
M 16	2.00 t	2.00 t	4.00 t	4.00 t	2.80 t	2.00 t	2.00 t	4.20 t	3.00 t	2.00 t
M 20	3.50 t	3.50 t	7.00 t	7.00 t	4.90 t	3.50 t	3.50 t	7.35 t	5.25 t	3.50 t
M 24	4.50 t	4.50 t	9.00 t	9.00 t	6.30 t	4.50 t	4.50 t	9.50 t	6.75 t	4.50 t
M 30	6.70 t	6.70 t	13.40 t	13.40 t	9.40 t	6.70 t	6.70 t	14.00 t	10.00 t	6.70 t

SAFETY INSTRUCTIONS

The above details specify the maximum load in metric tonnes, with the rotating load ring GN 586.1 fixed in place and set in load direction. The contact surface of the rotating load ring GN 586.1 must be flat and at a right angle to the tapped bore. When fixed to the member, the attachment bolt must be allowed to rotate freely by 360°. Only the hexagonal bolt supplied with the load ring may be used. The load ring must move freely and must not be supported by edges. Before applying the load, both the load ring and the attachment bolt must be turned in load direction, observing the permissible loading depending on the direction of the load ring. Rotating load rings are not suitable for frequent rotations under load. The specified loading values are valid for a minimum bolt embedment depth of 1,5 × nominal thread diameter in steel with a minimum tensile strength of 37 kp/mm² at an operating temperature of between -40 °C and +100 °C. Load capacities under different conditions provided on request. Operating instructions with more details and specifications are included with every delivery (see also www.elesa-ganter.com).

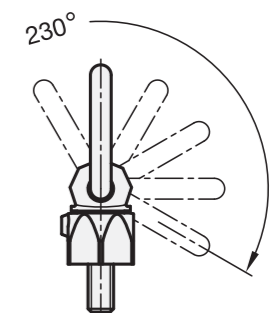

Load rings

for welding

SPECIFICATION

Types

- Type **A**: without steel tape
- Type **F**: with steel tape

Ring brackets
Steel, German Material No. 1.6541

- forged
- high-tensile tempered
- 100 % electro magnetic tensile tested to EN 1677
- plastic coated, pink

Weld-on block
Steel, S355 J2 + N (ST52-3N)

- forged, blank
- high-tensile tempered
- 100 % electro magnetic tensile tested to EN 1677

Retaining spring
Stainless Steel tape



INFORMATION

Load rings GN 587 for welding are designed for rapid mounting. They provide high dynamic and static strength and can be load from any direction with approved safety (safety factor 4) for all loading directions.

The steel tape (Type F) holds the ring in any position and dampens any noise caused by vibrations. All parts are undetachably connected. The two support lugs improve the bearing of hooks and enhance the support effect in the event of oblique suspension rings.

Load rings GN 587 comply with Mechanical Engineering Directive 2006 / 42 / EG.

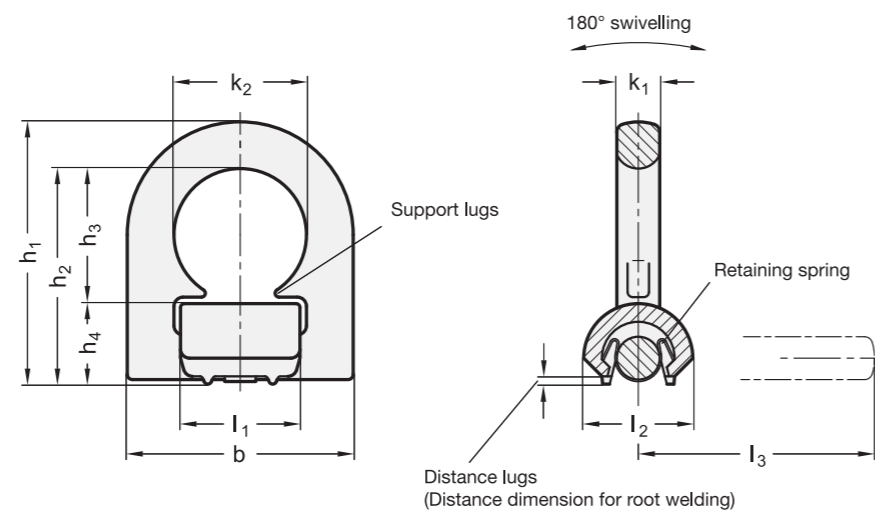

* Complete with type index of the Load rings:

- A without steel tape
- B with steel tape

GN 587

Description	b	h1	h2	h3	h4	k1	k2	l1	l2	l3	Nominal load in t (WLL)	⚖️
GN 587-66-*	66	79	65	40	25	13.5	38	33	32	71	1.5	320
GN 587-77-*	77	91	75	48	27	13.5	45	40	33	80	2.5	470
GN 587-87-*	87	101	83	52	31	16.5	51	46	42	91	4	757
GN 587-115-*	115	141	117	73	44	22.5	67	60	65	126.5	6.7	2000
GN 587-129-*	129	153	126	71	55	26.5	67	60	75	135.5	10	2300

Method of mounting									
Number	1	1	2	2	2	2	2	3 and 4	3 and 4
Angles of inclination	0°	90°	0°	90°	0° to 45°	45° to 60°	asymm.	0° to 45°	45° to 60°
Factor	1	1	2	2	14	1	1	2.1	1.5
b = 66	1.50 t	1.50 t	3.00 t	3.00 t	2.10 t	1.50 t	1.50 t	3.15 t	2.25 t
b = 77	2.50 t	2.50 t	5.00 t	5.00 t	3.50 t	2.50 t	2.50 t	5.25 t	3.75 t
b = 87	4.00 t	4.00 t	8.00 t	8.00 t	5.60 t	4.00 t	4.00 t	8.40 t	6.00 t
b = 115	6.70 t	6.70 t	13.40 t	13.40 t	9.50 t	6.70 t	6.70 t	14.00 t	10.00 t
b = 129	10.00 t	10.00 t	20.00 t	20.00 t	14.00 t	10.00 t	10.00 t	21.00 t	15.00 t

SAFETY INSTRUCTIONS

The above details refer to the maximum load in metric tonnes.

The configurations of the welding seam (HV) complies with the requirements of DIN 18800, i.e. the closed seam means that no corrosive deposits can settle; this also makes the load rings suitable for outside use.

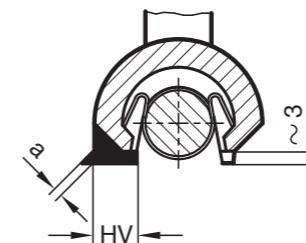

Loading ring size	Size Welding seam	Length	Volume in cm³
b = 66 (1.5 t)	HV 5 + a 3	2 x 33	1.2
b = 77 (2.5 t)	HV 7 + a 3	2 x 40	2.6
b = 87 (4.0 t)	HV 8 + a 3	2 x 46	3.2
b = 115 (6.7 t)	HV 12 + a 4	2 x 60	8.7
b = 129 (10.0 t)	HV 16 + a 4	2 x 60	15.5

Welding must be made by an approved welder in accordance with EN 287-1.

The specified load values are valid for an operating temperature of between -40 °C and + 100 °C. Load capacities under higher temperatures provided on request.

If the load rings are used for lashing instead of lifting, the nominal load is doubled.

Operating instructions with more details and specifications are included with every delivery.

Lifting points

for welding

SPECIFICATION

Steel, German Material No. 1.6541

- forged
- high-tensile tempered
- 100 % electro magnetic tensile tested to EN 1677
- phosphated

INFORMATION

Lifting points GN 589 are distinguished for their very low dimensions. They provide high dynamic and static strength and can be load from any direction with approved safety (safety factor 4) for all loading directions.

The rated load carrying capacity listed in the above table is clearly marked on the lifting point. It applies to the most unfavourable load application of the load types listed opposite

Lifting points GN 589 comply with Mechanical Engineering Directive 2006 / 42 / EG.

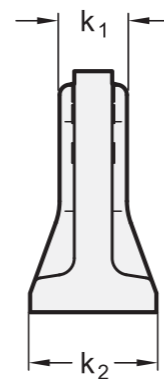
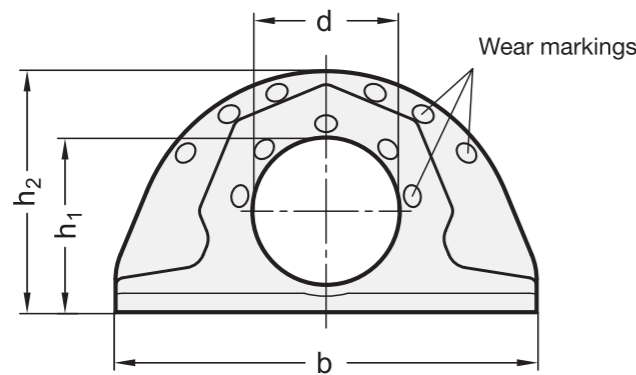

GN 589

Description	b	d	h1	h2	k1	k2	Nominal load (WLL)	max. permitted lashing force in daN (LC)	⚖️
GN 589-100	100	35	41.5	57	16	30	1.6	3200	435
GN 589-137	137	50	59	80	23	41	3.2	6400	1100
GN 589-172	172	60	71.5	99	27	51	5	10000	2160
GN 589-228	228	80	95	130	38	70	10	20000	5260

Method of mounting										
Number	1	1	2	2	2	2	3 and 4	3 and 4	3 and 4	
Angles of inclination	0°	90°	0°	90°	0° to 45°	45° to 60°	asymm.	0° to 45°	45° to 60°	asymm.
Factor	1	1	2	2	1.4	1	1	2.1	1.5	1
b = 100	1.6 t	1.6 t	3.2 t	3.2 t	2.2 t	1.6 t	1.6 t	3.4 t	2.4 t	1.6 t
b = 137	3.2 t	3.2 t	6.4 t	6.4 t	4.5 t	3.2 t	3.2 t	6.8 t	4.8 t	3.2 t
b = 172	5.0 t	5.0 t	10.0 t	10.0 t	7.1 t	5.0 t	5.0 t	10.6 t	7.5 t	5.0 t
b = 228	10.0 t	10.0 t	20.0 t	20.0 t	14.1 t	10.0 t	10.0 t	21.2 t	15.0 t	10.0 t

SAFETY INSTRUCTIONS



Use permitted
No traces of wear

Use not permitted
Criteria reached:
Material worn down to the wear marks

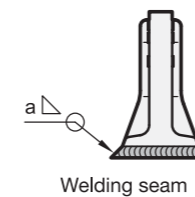

The above details refer to the maximum load in metric tonnes.

Carefully check the wear markings for the abrasion of the lifting point.

Lifting point	Size fillet seam	Length	Volume in cm ³
b = 100 (1.6 t)	a = 4	251	4.016
b = 137 (3.2 t)	a = 6	344	12.38
b = 172 (5.0 t)	a = 7	431	21.10
b = 228 (10.0 t)	a = 8	576	36.86

Welding must be made by an approved welder in accordance with EN 287-1.

The specified loading values are valid for an operating temperature of between -40 °C and +200 °C. Load capacities under higher temperatures provided on request.

Operating instructions with more details and specifications are included with every delivery (see also www.elesa-ganter.com)

Shackles

straight version

SPECIFICATION

Types

- Type **A**: with stud bolt
- Type **B**: Bolt with nut and split pin

Ring bracket

- Heat-treatable steel, die-forged
- hot-dip galvanised

Bolt

- Heat-treatable steel, die-forged
- galvanic zinc plated, lacquered

INFORMATION

High-strength, straight shackles GN 584 are made in analogy with the US Federal Specification RR-C-271 and feature sixfold safety standards, which means that the minimum failure load is at least six times greater than the value of the nominal load (WLL).

The rated size and the nominal load (WLL) are drop-forged into the shackle which makes it easier to select the proper sling gear. In general, the nominal load must not be exceeded.

The designs with nut and split pin (Type B) are normally recommended for permanent connections. The bolts are allowed to rotate, and the nuts are secured against inadvertent loosening with a split pin.

Operating instructions with more details and specifications are included with every delivery.

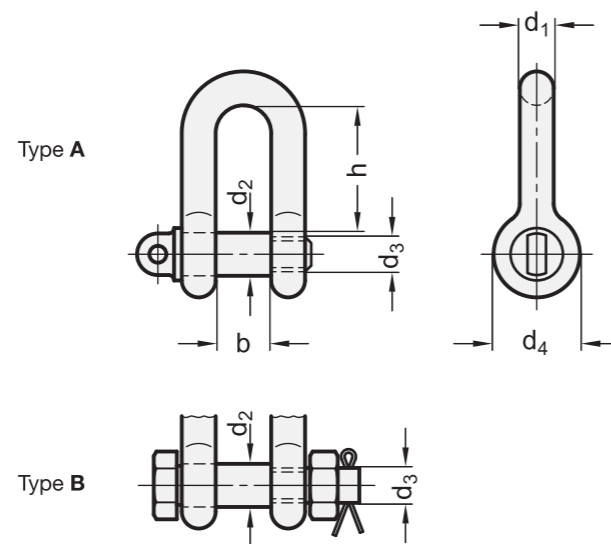

* Complete with type index of the Shackles (A or B)

- A** with stud bolt
- B** Bolt with nut and split pin

GN 584

Description	d1 Nominal size	d1 In inch	b ±1	d2 ±0.5	d3** UNC-thread	d4	h	Nominal load (WLL)	⚖
GN 584-6-*	6	1/4	12	8	5/16	17	22	0.5 t [5.0 kN]	45
GN 584-8-*	8	5/16	13	10	3/8	21	26	0.75 t [7.5 kN]	80
GN 584-10-*	10	3/8	16	12	7/16	26	31	1.0 t [10 kN]	120
GN 584-11-*	11	7/16	18	14	1/2	28	36	1.5 t [15 kN]	180
GN 584-13-*	13	1/2	21	16	5/8	30	41	2.0 t [20 kN]	350
GN 584-16-*	16	5/8	27	19	3/4	42	51	3.25 t [32.5 kN]	595
GN 584-19-*	19	3/4	32	22	7/8	48	60	4.75 t [47.5 kN]	900
GN 584-22-*	22	7/8	36	25	1	57	71	6.5 t [65.0 kN]	1200
GN 584-25-*	25	1	43	28	1 1/8	62	81	8.5 t [85.0 kN]	1800

** in general, the bolts and screws are threaded as specified. Variances are possible, however.

Shackles

cranked version

SPECIFICATION

Types

- Type **A**: with stud bolt
- Type **B**: Bolt with nut and split pin

Ring bracket

- Heat-treatable steel, die-forged
- hot-dip galvanised

Bolt

- Heat-treatable steel, die-forged
- galvanic zinc plated, lacquered

INFORMATION

High-strength, straight shackles GN 585 are made in analogy with the US Federal Specification RR-C-271 and feature sixfold safety standards, which means that the minimum failure load is at least six times greater than the value of the nominal load (WLL).

The cranked shape is particularly suitable for applications where the shackles are exposed to multiple loads.

The rated size and the nominal load (WLL) are drop-forged into the shackle which makes it easier to select the proper sling gear. In general, the nominal load must not be exceeded.

The designs with nut and split pin (Type B) are normally recommended for permanent connections. The bolts are allowed to rotate, and the nuts are secured against inadvertent loosening with a split pin.

Operating instructions with more details and specification are included with every delivery.

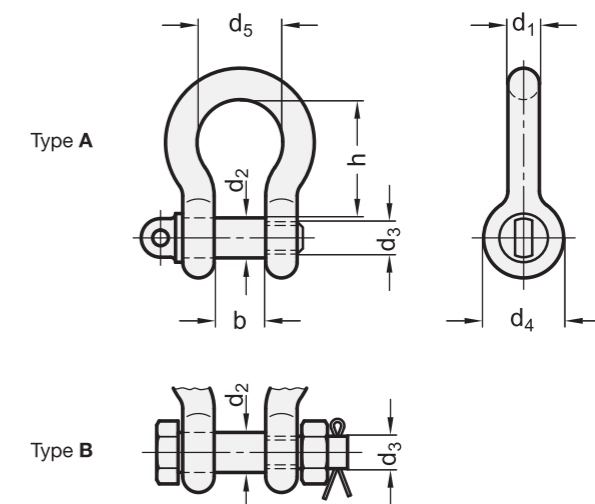

* Complete with type index of the Shackles (A or B)

- A** with stud bolt
- B** Bolt with nut and split pin

GN 585

Description	d1 Nominal size	d1 In inch	b ±1	d2 ±0.5	d3** UNC-thread	d4	d5	h	Nominal load (WLL)	⚖
GN 585-6-*	6	1/4	12	8	5/16	17	19	28	0.5 t [5.0 kN]	50
GN 585-8-*	8	5/16	13	10	3/8	21	21	31	0.75 t [7.5 kN]	80
GN 585-10-*	10	3/8	16	12	7/16	26	24	36	1.0 t [10 kN]	130
GN 585-11-*	11	7/16	18	14	1/2	28	27	42	1.5 t [15 kN]	220
GN 585-13-*	13	1/2	21	16	5/8	30	30	48	2.0 t [20 kN]	350
GN 585-16-*	16	5/8	27	19	3/4	42	38	60	3.25 t [32.5 kN]	650
GN 585-19-*	19	3/4	32	22	7/8	48	45	71	4.75 t [47.5 kN]	1050
GN 585-22-*	22	7/8	36	25	1	57	51	84	6.5 t [65.0 kN]	1400
GN 585-25-*	25	1	43	28	1 1/8	62	59	95	8.5 t [85.0 kN]	2300

** in general, the bolts and screws are threaded as specified. Variances are possible, however.

Lifting pins

Steel / Stainless Steel, self-locking

SPECIFICATION

Version in Steel

Steel **ST**

- Stud, shackle
- heat-treated, manganese phosphated

Version in Stainless Steel

Stainless Steel **NI**

- Stud AISI 630
- age-hardened
- Shackle AISI 316Ti
- Push button
- Aluminium, red anodized
- Spring
- Stainless Steel



INFORMATION

Lifting pins GN 1130 are carrier elements designed for fast and easy use. Pressing the red aluminium button will release the locking effect of the locking ball, allowing the load bolt to be moved in or out of the holding bore hole. The shackle rotates by at least 180°, with a safety flange fitted as a safeguard against inadvertent operation. Depending on the direction of pull, the ball load bolt may move freely by 360° in the holding bore hole.

Sling and lifting gear permanently remaining at the workpiece (e.g. load rings) is no longer necessary. Holding bore holes with d1 H11 are sufficient in use with corresponding strength of materials.

Furthermore, the GN 1132 (see page 1098) holding bushings are also available.

For more user guidelines, see the operating instruction enclosed with every lifting pin.

TECHNICAL INFORMATION

- Stainless Steel characteristics (see page A26)

ACCESSORY

- Holding bushings GN 1132 (see page 1098)

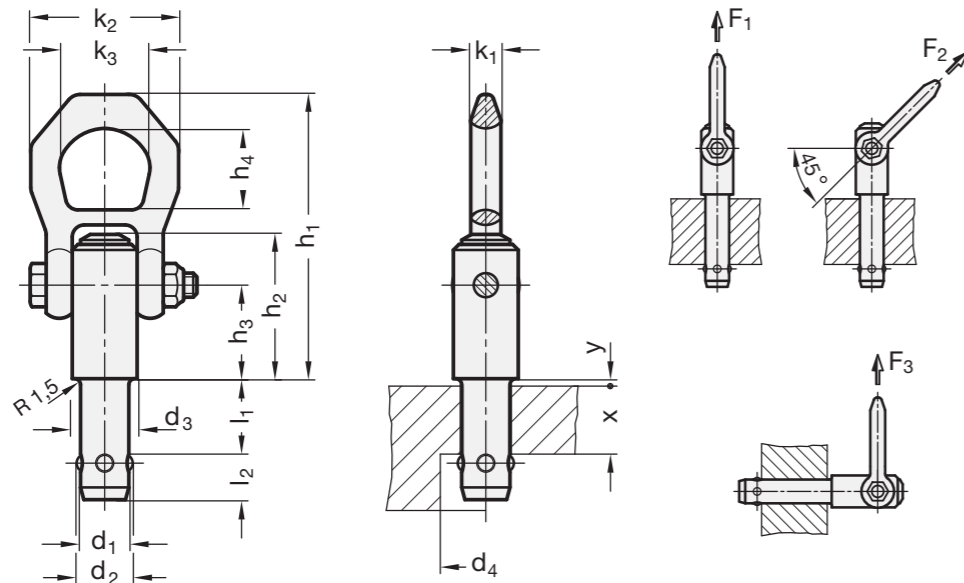

GN 1130

Description	d1 -0.04/-0.08	l1 +1	d2	d3	d4 min.	h1	h2	h3	h4	k1	k2	k3	l2	x min.	y	Nominal load in kN F1	Nominal load in kN F2	Nominal load in kN F3	⚖️
GN 1130-8-10-ST	8	10	9.35	21.5	9.9	87.5	38.5	25.7	27	9.5	49	30	8.75	5	1.5	1.5*	1.2*	0.5*	220
GN 1130-8-15-ST	8	15	9.35	21.5	9.9	87.5	38.5	25.7	27	9.5	49	30	8.75	5	1.5	1.5*	1.2*	0.5*	226
GN 1130-8-25-ST	8	25	9.35	21.5	9.9	87.5	38.5	25.7	27	9.5	49	30	8.75	10	1.5	1.5*	1.2*	0.5*	229
GN 1130-8-35-ST	8	35	9.35	21.5	9.9	87.5	38.5	25.7	27	9.5	49	30	8.75	20	1.5	1.5*	1.2*	0.5*	232
GN 1130-10-15-ST	10	15	11.7	21.5	12.2	87.5	38.5	25.7	27	9.5	49	30	10.2	5	1.5	2.7*	2.4*	2.1*	227
GN 1130-10-25-ST	10	25	11.7	21.5	12.2	87.5	38.5	25.7	27	9.5	49	30	10.2	15	1.5	2.7*	2.4*	2.1*	236
GN 1130-10-35-ST	10	35	11.7	21.5	12.2	87.5	38.5	25.7	27	9.5	49	30	10.2	25	1.5	2.7*	2.4*	2.1*	243
GN 1130-10-50-ST	10	50	11.7	21.5	12.2	87.5	38.5	25.7	27	9.5	49	30	10.2	40	1.5	2.7*	2.4*	2.1*	252
GN 1130-12-15-ST	12	15	14.2	21.5	14.7	87.5	38.5	25.7	27	9.5	49	30	11	5	1.5	3.5*	3.2*	2.8*	243
GN 1130-12-25-ST	12	25	14.2	21.5	14.7	87.5	38.5	25.7	27	9.5	49	30	11	10	1.5	3.5*	3.2*	2.8*	247
GN 1130-12-35-ST	12	35	14.2	21.5	14.7	87.5	38.5	25.7	27	9.5	49	30	11	20	1.5	3.5*	3.2*	2.8*	258
GN 1130-12-50-ST	12	50	14.2	21.5	14.7	87.5	38.5	25.7	27	9.5	49	30	11	35	1.5	3.5*	3.2*	2.8*	267
GN 1130-16-25-ST	16	25	18.6	25	19.2	92.8	47.5	31	27	9.5	49	30	15.1	10	1.5	4.8*	4.5*	4.1*	318
GN 1130-16-50-ST	16	50	18.6	25	19.2	92.8	47.5	31	27	9.5	49	30	15.1	15	1.5	4.8*	4.5*	4.1*	350
GN 1130-16-75-ST	16	75	18.6	25	19.2	92.8	47.5	31	27	9.5	49	30	15.1	35	1.5	4.8*	4.5*	4.1*	392
GN 1130-20-50-ST	20	50	24.5	30	25	114	55.9	36.5	32.6	11	56	36	19.7	25	1.5	10*	8.5*	6.5*	440
GN 1130-20-75-ST	20	75	24.5	30	25	114	55.9	36.5	32.6	11	56	36	19.7	45	1.5	10*	8.5*	6.5*	480

GN 1130-NI

STAINLESS STEEL

Description	d1 -0.04/-0.08	l1 +1	d2	d3	d4 min.	h1	h2	h3	h4	k1	k2	k3	l2	x min.	y	Nominal load in kN F1	Nominal load in kN F2	Nominal load in kN F3	⚖️
GN 1130-8-10-NI	8	10	9.35	21.5	9.9	87.5	38.5	25.7	27	9.5	49	30	8.75	5	1.5	1.5*	1.2*	0.5*	228
GN 1130-8-15-NI	8	15	9.35	21.5	9.9	87.5	38.5	25.7	27	9.5	49	30	8.75	5	1.5	1.5*	1.2*	0.5*	229
GN 1130-8-25-NI	8	25	9.35	21.5	9.9	87.5	38.5	25.7	27	9.5	49	30	8.75	10	1.5	1.5*	1.2*	0.5*	233
GN 1130-8-35-NI	8	35	9.35	21.5	9.9	87.5	38.5	25.7	27	9.5	49	30	8.75	20	1.5	1.5*	1.2*	0.5*	236
GN 1130-10-15-NI	10	15	11.7	21.5	12.2	87.5	38.5	25.7	27	9.5	49	30	10.2	5	1.5	2.7*	2.4*	2.1*	233
GN 1130-10-25-NI	10	25	11.7	21.5	12.2	87.5	38.5	25.7	27	9.5	49	30	10.2	15	1.5	2.7*	2.4*	2.1*	238
GN 1130-10-35-NI	10	35	11.7	21.5	12.2	87.5	38.5	25.7	27	9.5	49	30	10.2	25	1.5	2.7*	2.4*	2.1*	260
GN 1130-10-50-NI	10	50	11.7	21.5	12.2	87.5	38.5	25.7	27	9.5	49	30	10.2	40	1.5	2.7*	2.4*	2.1*	255
GN 1130-12-15-NI	12	15	14.2	21.5	14.7	87.5	38.5	25.7	27	9.5	49	30	11	5	1.5	3.5*	3.2*	2.8*	242
GN 1130-12-25-NI	12	25	14.2	21.5	14.7	87.5	38.5	25.7	27	9.5	49	30	11	10	1.5	3.5*	3.2*	2.8*	253
GN 1130-12-35-NI	12	35	14.2	21.5	14.7	87.5	38.5	25.7	27	9.5	49	30	11	20	1.5	3.5*	3.2*	2.8*	260
GN 1130-12-50-NI	12	50	14.2	21.5	14.7	87.5	38.5	25.7	27	9.5	49	30	11	35	1.5	3.5*	3.2*	2.8*	268
GN 1130-16-25-NI	16	25	18.6	25	19.2	92.8	47.5	31	27	9.5	49	30	15.1	10	1.5	4.8*	4.5*	4.1*	316
GN 1130-16-50-NI	16	50	18.6	25	19.2	92.8	47.5	31	27	9.5	49	30	15.1	15	1.5	4.8*	4.5*	4.1*	355
GN 1130-16-75-NI	16	75	18.6	25	19.2	92.8	47.5	31	27	9.5	49	30	15.1	35	1.5	4.8*	4.5*	4.1*	398
GN 1130-20-50-NI	20	50	24.5	30	25	114	55.9	36.5	32.6	11	56	36	19.7	25	1.5	10*	8.5*	6.5*	398
GN 1130-20-75-NI	20	75	24.5	30	25	114	55.9	36.5	32.6	11	56	36	19.7	45	1.5	10*	8.5*	6.5*	438

* with 5-fold anti-fracture safety