

Scales, scale rings, level vials

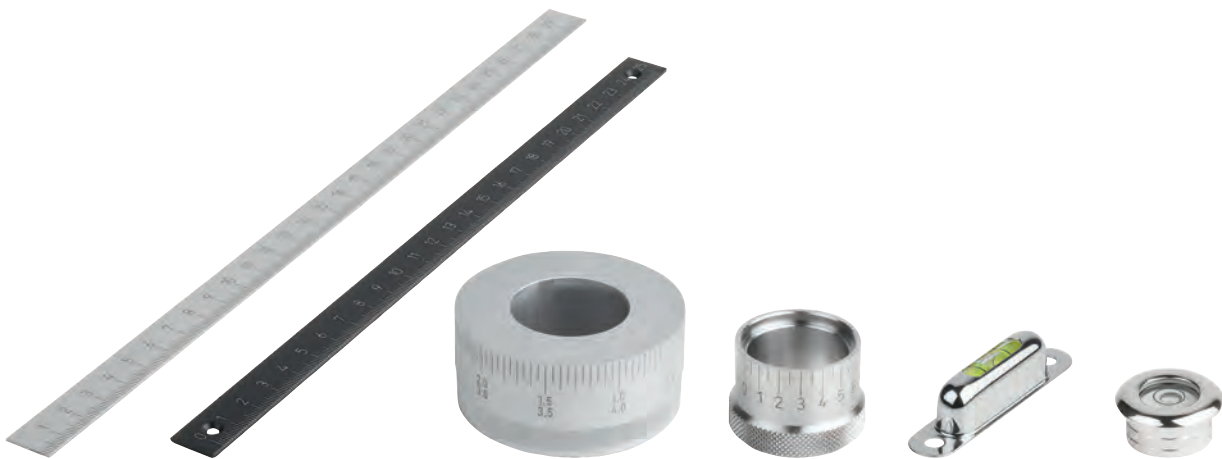

Linear scales

self adhesive or with screw holes, aluminium

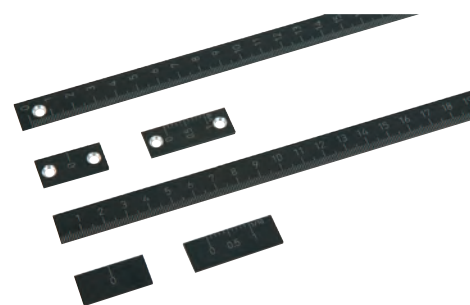

self-adhesive horizontal mounting

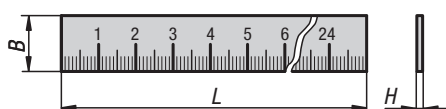

with holes horizontal mounting

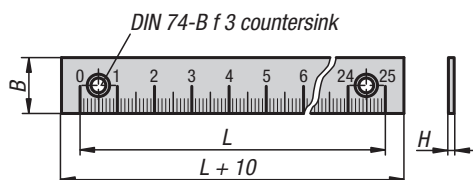

Vernier scale

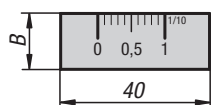

zero mark

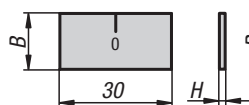

Vernier scale

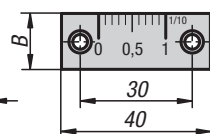

zero mark

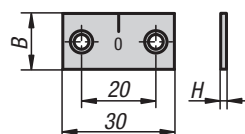

self-adhesive vertical mounting

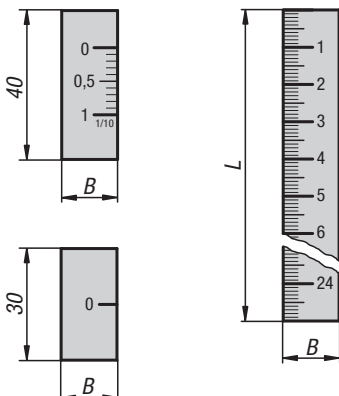

with holes vertical mounting

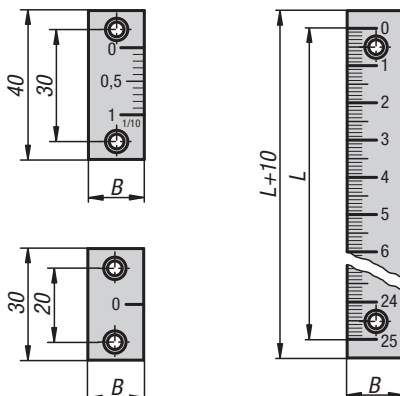

Material:
Aluminium.

Version:
Black anodised

Sample order:
K0757.000010X0250 (include length L)

Note:
Rigid design aluminium linear scales with self-adhesive back or with screw holes.
Cross section 15 x 2 mm.

Black anodised surface and high contrast graduations for legibility without shading. The graduations are deep lasered.

- On request:**
- Zero mark lower right or centre
 - Graduations upper right or both sides
 - Other lengths

Length L	No. of holes
250	2
500	3
750	4
1000	5

Linear scales, self adhesive or with screw holes, aluminium

Order No. self adhesive	Order No. fastening holes	Product type	Assembly position	Zero point	Division	Graduations	B	H	L
K0757.000010X	K0757.100010X	scale	horizontal	left	1 mm	bottom	15	2	250/500/750/1000
K0757.010010X	K0757.110010X	scale	vertical	top	1 mm	left	15	2	250/500/750/1000

Vernier scale and zero reference, self adhesive or with holes, aluminium

Order No. self adhesive	Order No. fastening holes	Product type	Assembly position	Zero point	Graduations	B	H
K0757.0001	K0757.1001	vernier scale	horizontal	left	top	15	2
K0757.0101	K0757.1101	vernier scale	vertical	top	right	15	2
K0757.00	K0757.10	zero reference mark	horizontal	-	-	15	2
K0757.01	K0757.11	zero reference mark	vertical	-	-	15	2

Linear scales

self-adhesive or with screw holes, aluminium

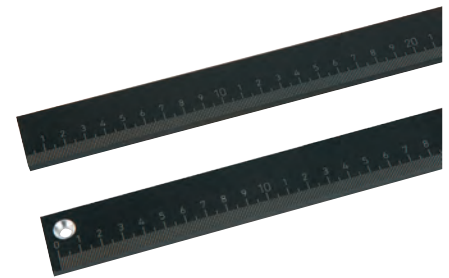

self-adhesive

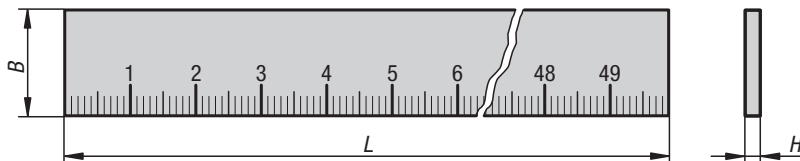

with holes

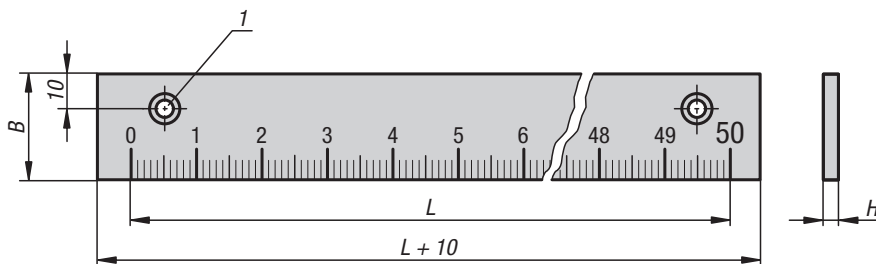

Length L	No. of holes
500	2
1000	3

Material:
Aluminium.

Version:
Scale surface ground and black anodised

Sample order:
K0758.000010X0500 (include length L)

Note:
Rigid, heavy-duty design aluminium linear scales.
Cross section 30 x 6 mm.

Black anodised surface and high contrast graduations for legibility without shading.
The graduations are deep lasered.

On request:
– Zero mark right or centre
– Graduations top or both sides
– Other lengths

Drawing reference:
1) counterbore to DIN 74-B f 5

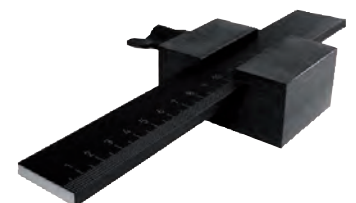

Linear scales self-adhesive or with screw holes, aluminium

Order No. self adhesive	Order No. fastening holes	Assembly position	Zero point	Division	Graduations	B	H	L
K0758.000010X	K0758.100010X	horizontal	left	1 mm	bottom	30	6	500/1000

Scale tape, steel

self-adhesive

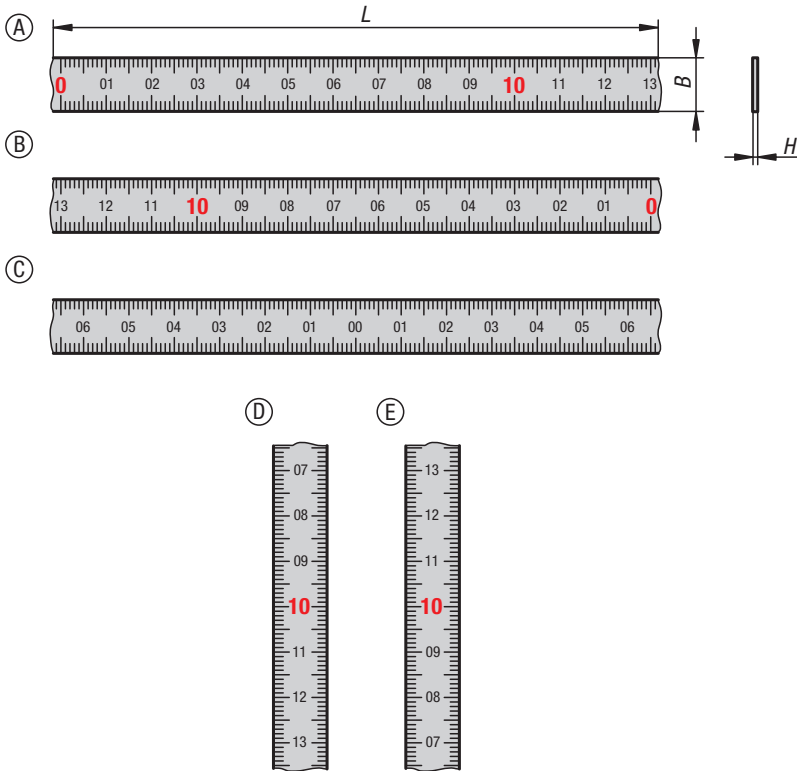
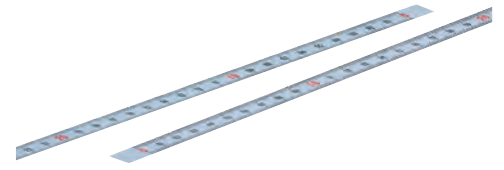

Material:
Steel.

Version:
Painted white.

Sample order:
K1301.00021010X0300 (include length L)

Note:
Scale tapes with mm graduations on top and bottom edge in black and consecutive centimetre numbering. Decimal numbers in red (under 1 m lengths and with centre zero black only).
The scale tapes are self-adhesive with a peel-away foil film on the back. The film must be removed before use.

Application:
The scale tapes can be used where a precise measurement is required. They are used on machines, work tables and workbenches.



Scale tapes, steel, self-adhesive

Order No.	Kind of fastening	Product type	Form	Assembly position	Zero point	Division	Graduations	B	H	L
K1301.00021010X	self adhesive	scale tape	A	horizontal	left	1 mm	both sides	10	0,5	300/500/1000/2000/3000/5000/6000
K1301.00021013X	self adhesive	scale tape	A	horizontal	left	1 mm	both sides	13	0,5	300/500/1000/2000/3000/5000/6000
K1301.00221010X	self adhesive	scale tape	B	horizontal	right	1 mm	both sides	10	0,5	300/500/1000/2000/3000/5000/6000
K1301.00221013X	self adhesive	scale tape	B	horizontal	right	1 mm	both sides	13	0,5	300/500/1000/2000/3000/5000/6000
K1301.00121013X	self adhesive	scale tape	C	horizontal	centre	1 mm	both sides	13	0,5	800/2000/2500/8000
K1301.01021013X	self adhesive	scale tape	D	vertical	top	1 mm	both sides	13	0,5	1000/2000/3000/5000
K1301.01221013X	self adhesive	scale tape	E	vertical	bottom	1 mm	both sides	13	0,5	1000/2000/3000/5000

Linear scales

self-adhesive, stainless steel

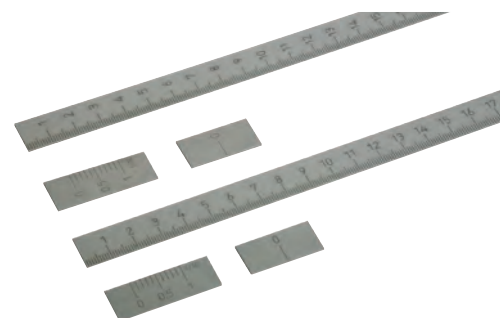

horizontal mounting

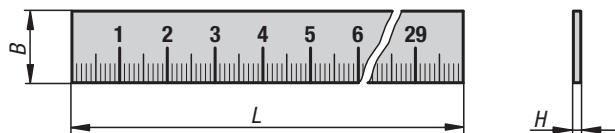

Vernier scale

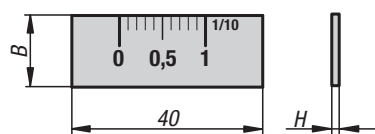

zero mark

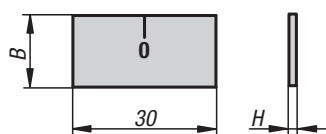

vertical mounting

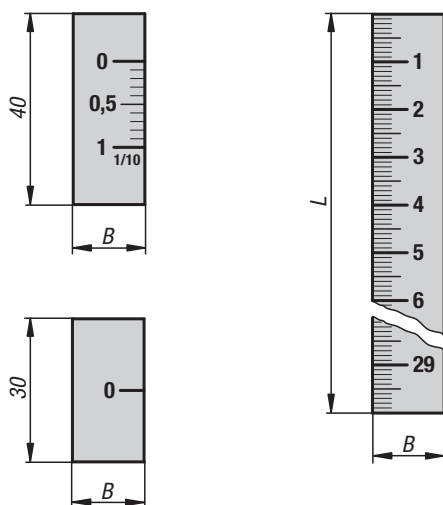

Material:
Stainless steel 1.4310.

Version:
Bright.

Sample order:
K0759.000010X0300 (include length L)

Note:
Rigid design stainless steel linear scales with self-adhesive back.
Cross section 15 x 1 mm.

Matt surface and black high contrast graduations. The graduations are deep lasered.

On request:
– Zero mark lower right or centre
– Graduations upper right or both sides
– Other lengths

Linear scales self-adhesive, stainless steel

Order No. self adhesive	Product type	Assembly position	Zero point	Division	Graduations	B	H	L
K0759.000010X	scale	horizontal	left	1 mm	bottom	15	1	300/500/700/1000
K0759.010010X	scale	vertical	top	1 mm	left	15	1	300/500/700/1000

Vernier scale and zero reference, self-adhesive, stainless steel

Order No.	Kind of fastening	Product type	Assembly position	Zero point	Graduations	B	H
K0759.0001	self adhesive	vernier scale	horizontal	left	top	15	1
K0759.0101	self adhesive	vernier scale	vertical	top	right	15	1
K0759.00	self adhesive	zero reference mark	horizontal	-	-	15	1
K0759.01	self adhesive	zero reference mark	vertical	-	-	15	1

Bullseye levels

in frame, to screw on



Material:

Frame brass.
Bullseye level body polyamide.

Version:

Nickel-plated and high-gloss polished.

Sample order:

K1154.1141030

Note:

Bubble levels are used as a type of zero indicator instrument for checking horizontal inclination in e.g. spirit levels, inclinometers, metrology instruments and machine constructions.

These bullseye levels can either be screwed down using the three holes (Form A) or recessed (Form B).

- Form A: calibrated to the ground bottom face
- Form B: calibrated to the underside of the flange
- Sensitivity in angular minutes for 2 mm bubble travel
- Clear filling
- Black contrast ring
- White level base

Temperature range:

-35 °C up to +55 °C.

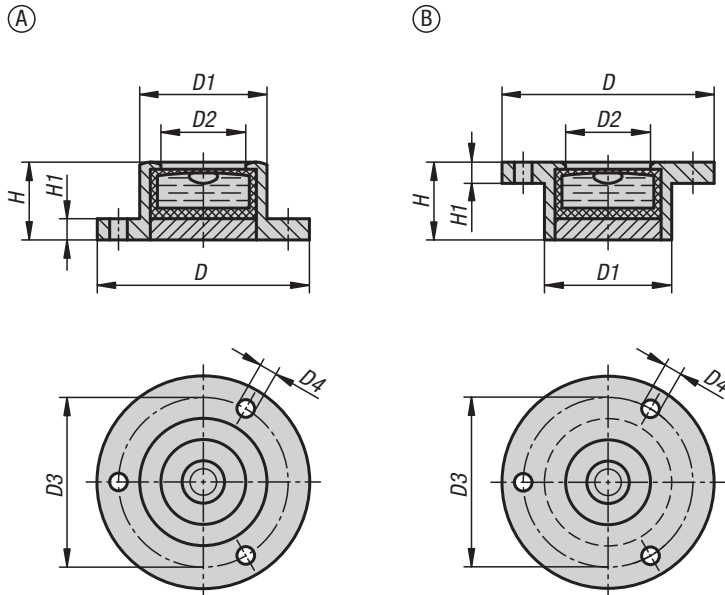

Bullseye levels in a frame to screw down

Order No.	Form	Version 1	D	D1	D2	D3	D4	H	H1	Sensitivity
K1154.1141030	A	with mounting flange	20	14	10	17	1,6	10	1,8	30'
K1154.1171030	A	with mounting flange	25	17	12	21	2	10	2	30'
K1154.1181130	A	with mounting flange	30	18	12	24	2,5	11	3	30'
K1154.1281430	A	with mounting flange	40	28	20	34,5	2,5	14	4	30'
K1154.1341530	A	with mounting flange	50	34	25	43	3	15	5	30'
K1154.2141030	B	inlet flange	20	14	10	17	1,6	10	1,8	30'
K1154.2171030	B	inlet flange	25	17	12	21	2	10	2	30'
K1154.2181130	B	inlet flange	30	18	12	24	2,5	11	3	30'
K1154.2281430	B	inlet flange	40	28	20	34,5	2,5	14	4	30'
K1154.2341530	B	inlet flange	50	34	25	43	3	15	5	30'

Bullseye levels

in plastic frame



Material:

Frame PMMA.

Bullseye level body acrylic glass.

Version:

black.

Sample order:

K1153.171053

Note:

Bubble levels are used as a type of zero indicator instrument for checking horizontal inclination in e.g. spirit levels, inclinometers, metrology instruments and machine constructions.

These bullseye levels can be mounted using the three fastening holes.

- Calibrated to the ground bottom face
- Sensitivity in angular minutes for 2 mm bubble travel
- Clear filling
- Black contrast ring
- White level base

Temperature range:

-35 °C up to +55 °C.

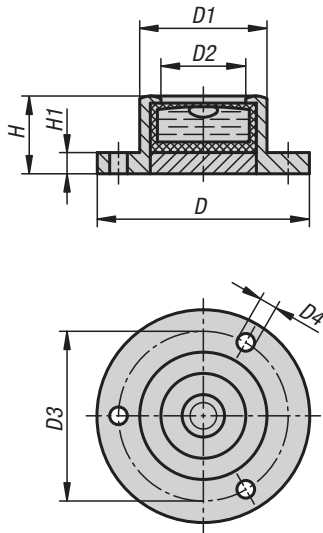

Bullseye levels in a plastic frame

Order No.	D	D1	D2	D3	D4	H	H1	Sensitivity
K1153.171053	26	17	11	21,5	2,3	10	3	53'
K1153.201140	30	20	14	25	2,3	11	3	40'
K1153.241153	36	24	18,5	29	3,2	11	3	53'

Bullseye levels

with bead-edged frame



Material:

Frame brass.
Bullseye level body polyamide.

Version:

Nickel-plated and high-gloss polished.

Sample order:

K1152.181030

Note:

Bubble levels are used as a type of zero indicator instrument for checking horizontal inclination in e.g. spirit levels, inclinometers, metrology instruments and machine constructions.

- Sensitivity in angular minutes for 2 mm bubble travel
- The bullseye level is calibrated to underside of the flange
- Bead edge with serrations for recessing
- Clear filling
- Black contrast ring
- White level base

Temperature range:

-35 °C up to +55 °C.

Assembly:

- Measure the level body
- Assemble by pressing in a hole that is 0.02 mm – 0.03 mm smaller than the \emptyset of the level body
- A chamfer on the hole will ease pressing in

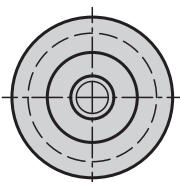
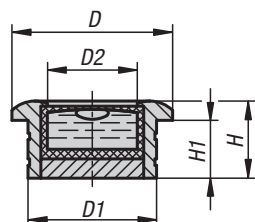

Bullseye levels with bead-edge frame

Order No.	D	D1	D2	H	H1	Sensitivity
K1152.181030	20	18	12	10	8	30'
K1152.201230	25	20	14	12	9	30'
K1152.281330	30	28	20	13	10	30'

Bullseye levels

in round frame



Material:

Frame brass.

Bullseye level body polyamide.

Version:

Nickel-plated and high-gloss polished.

Sample order:

K1155.1140930

Note:

Bubble levels are used as a type of zero indicator instrument for checking horizontal inclination in e.g. spirit levels, inclinometers, metrology instruments and machine constructions.

Form B can be fastened using a grub screw.

- Sensitivity in angular minutes for 2 mm bubble travel
- The bullseye level is calibrated to the seating face of frame
- Various threads are available
- Clear filling
- Black contrast ring
- White level base

Temperature range:

-35 °C up to +55 °C.

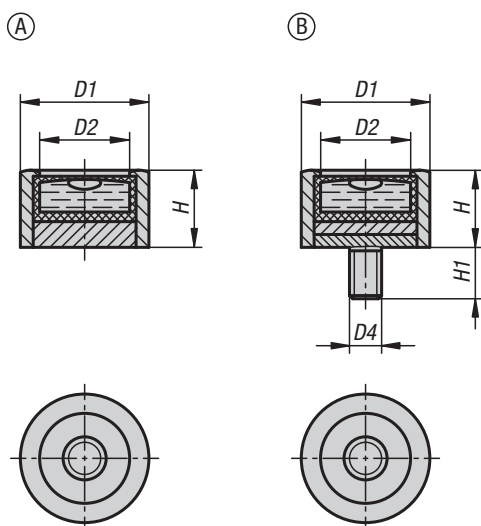

Bullseye levels in a round frame

Order No.	Form	D1	D2	D4	H	H1	Sensitivity
K1155.1140930	A	14	10	-	9,5	-	30'
K1155.1181130	A	18	12	-	11	-	30'
K1155.1201230	A	20	14	-	12	-	30'
K1155.1301530	A	30	21	-	15	-	30'
K1155.2140730	B	14	10	M4	7,5	5	30'
K1155.2181230	B	18	12	M6	12	5	30'
K1155.2201230	B	20	14	M5	12	8	30'
K1155.2301530	B	30	21	M8	15	10	30'

Bullseye level body

**Material:**

Bullseye level body stainless steel up to Ø14 mm, then aluminium.

Sight window glass.

Version:

Aluminium black anodised.

Sample order:

K1156.120725

Note:

Bubble levels are used as a type of zero indicator instrument for checking horizontal inclination in e.g. spirit levels, inclinometers, metrology instruments and machine constructions.

Excellent bubble contour, with internal bubble ring to eliminate planar parallaxes.

- Sensitivity in angular minutes for 2 mm bubble travel
- Clear filling

Temperature range:

-35 °C up to +55 °C.

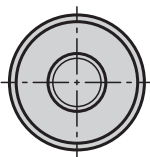
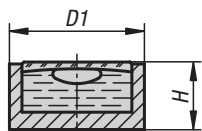

Bullseye level body

Order No.	Main material	D1	H	Sensitivity
K1156.120710	stainless steel	12	6	10'
K1156.120725	stainless steel	12	6	25'
K1156.140710	aluminium	14	6,5	10'
K1156.140720	aluminium	14	6,5	20'
K1156.150710	aluminium	15	6,5	10'
K1156.150720	aluminium	15	6,8	20'
K1156.200810	aluminium	20	8,5	10'
K1156.200820	aluminium	20	8,5	20'
K1156.250910	aluminium	25	8,5	10'
K1156.250920	aluminium	25	8,5	20'

Bullseye level body

plastic

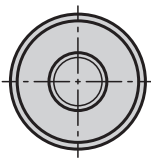
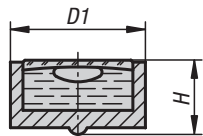

Material:
Polyamide

Version:
Ivory coloured.

Sample order:
K1157.120720

Note:

Bubble levels are used as a type of zero indicator instrument for checking horizontal inclination in e.g. spirit levels, inclinometers, metrology instruments and machine constructions.

With internal black contrast ring for better bubble contour.

- Protruding fill point underneath.
- Sensitivity in angular minutes for 2 mm bubble travel
- Clear filling

Temperature range:
-35 °C up to +55 °C.

Bullseye level body plastic

Order No.	D1	H	Sensitivity
K1157.120720	12	7	20'
K1157.140730	14	7,7	30'
K1157.150720	15	7,7	20'
K1157.180930	18	9,2	30'
K1157.201040	20	10,6	40'
K1157.251230	25	11,5	30'

Tubular bubble levels

with frame to screw on

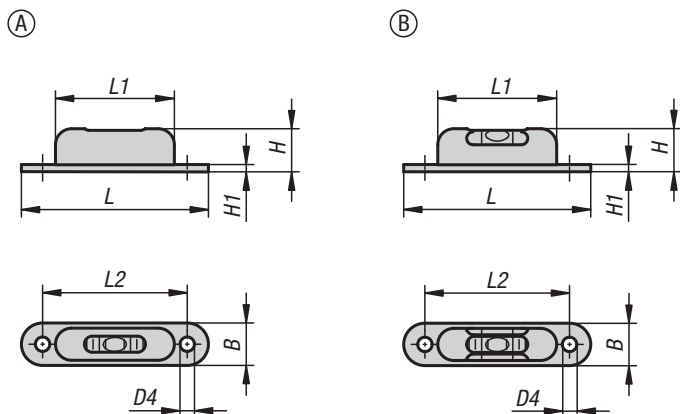

Material:

Frame brass.

Tubular bubble vial glass.

Version:

Nickel-plated and high-gloss polished. Form B: black anodised.

Sample order:

K1158.1571350

Note:

Bubble levels are used as a type of zero indicator instrument for checking horizontal inclination in e.g. spirit levels, inclinometers, metrology instruments and machine constructions.

The tubular levels can be fastened using the two holes.

- Form A: one sight window
- Form B: three sight windows
- Sensitivity in angular minutes for 2 mm bubble travel
- Green filling

Temperature range:

-35 °C up to +55 °C.

Tubular levels with frame to screw down

Order No.	Form	B	D4	H	H1	L	L1	L2	Sensitivity
K1158.1571350	A	12,3	4,5	13	1	57	37	45	50'
K1158.2571305	B	12,3	4,5	13	1	57	37	45	5'

Scale rings to customer specifications



Material:
Steel 1.192.

Version:
Matt-finished chromium-plated.
Scale marks and figures in black.

Note:
The above version has proven itself for „avoiding reading errors“. The matt-finished chromium-plated surface and the black scale marks and figures contrast very well.
However, other surface finishes and materials are available on request.