





ROTATIONAL SERIES

The rotational moulding of plastics requires clamping devices able to work in a quick and safe way at very high temperatures (240-300°C.) without any hesitation when opening and clamping. So, we have achieved a full series of clamps suitable to this type of work. This series is in part a spin off from the Speedy Block's mass production with the contribution of suitable alterations (couplings with different tolerances, modified geometries, different finishings, etc.), and it has been optimized following the suggestions and expectations of the users which urged their design.



VERTICAL SERIES FOR HIGH TEMPERATURES

Material:

Phosphated steel

Riveted pivots:

Phosphated steel

Supporting bushes:

Hardened and ground steel.

Performance:

With eye bolt clamping lever for inserting the spindle.

Spindles:

To be ordered separately (see Accessories on page 87)

Features and applications:

The tools of this series are generally used in rotational forging, as it is able to operate at high temperatures (240-300°C).

This is made possible thanks to their finish, the interposition of special copper grease between the parts and appropriate tolerances between the couplings.

FORM ER

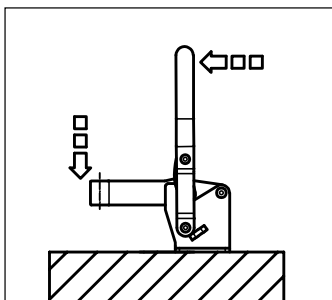
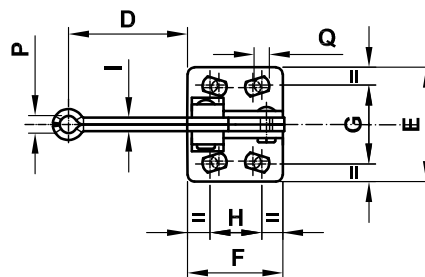
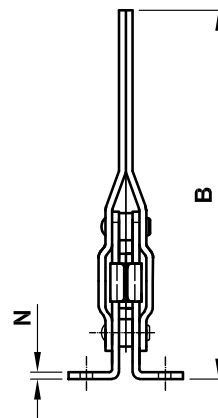
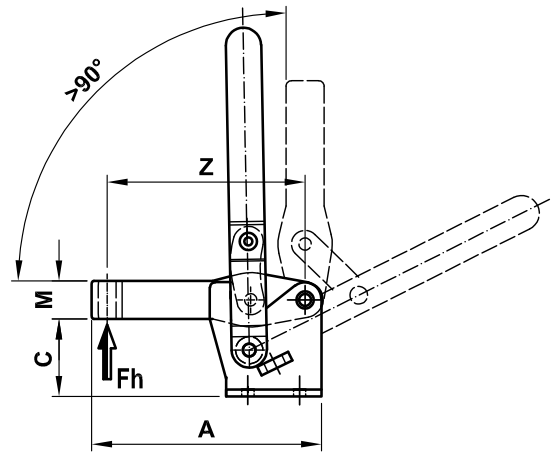

Code	Description	A	B	C	D	E	F	G	H	I	M	N	P	Q	Z	Fh (daN)	gr.
AR530	130/ER	85	136	28	44	42	35	27÷29	12,5÷19	5	16	2,5	6,5	5,6	73	160	210
AR540	230/ER	110	164	33,5	60	45	43	32	19÷20	6	18	3	8	6,7	96	200	330
AR550	330/ER	128	189	43	69	65	50	45÷46	29÷32	7	22	3,5	10,5	8,5	111	240	519

**FORM
OR**

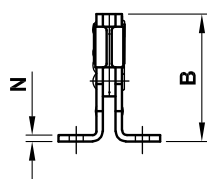
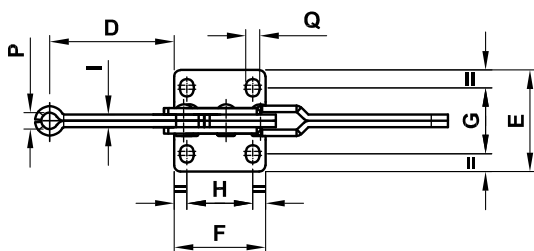
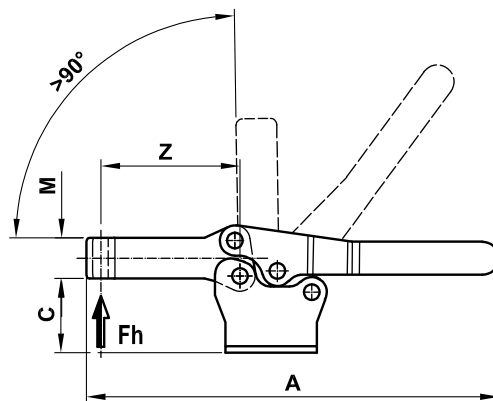

**HORIZONTAL SERIES
FOR HIGH TEMPERATURES**

Material:

Phosphated steel

Riveted pivots:

Phosphated steel

Supporting bushes:

Hardened and ground steel.

Performance:

With eye bolt clamping lever for inserting the spindle.

Spindles:

To be ordered separately (see Accessories on page 87).

Features and applications:

The tools of this series are generally used in rotational forging, as it is able to operate at high temperatures (240-300°C).

This is made possible thanks to their finish, the interposition of special copper grease between the parts and appropriate tolerances between the couplings.

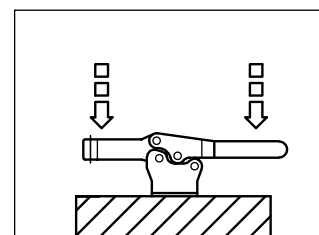

Code	Description	A	B	C	D	E	F	G	H	I	M	N	P	Q	Z	Fh (daN)	gr.
AR145	130/OR	165	51	30,5	50	40	36	22,4÷28,4	26	5	16	2,5	6,5	5,6	56	100	185
AR280	230/OR	190	61,5	36,5	56	44	44	26÷31,5	26	6	18	3	8,5	6,6	63	170	300
AR380	355/OR	260,5	83	50	89,5	58	60	38,8÷43	41	7	22	3,5	10,5	8,6	98,5	180	700

DOUBLE ROD SERIES FOR HIGH TEMPERATURES

Material:

Base and lever in hot pressed rough steel

Rod:

Rough steel

Hooking bracket:

Rough steel.

Performance:

The tool comes with a bar with hooking bracket and nuts.

Features and applications:

The tools of this series are generally used in rotational forging, as it is able to operate at high temperatures (240-300°C).

This is made possible thanks to their finish, the interposition of special copper grease between the parts and appropriate tolerances between the couplings.

In addition to the standard length of the U rods, a variety of other lengths are given on page 57.

Therefore, when ordering, indicate:

T2S = Tool with Standard Double Threaded Rod and hooking bracket

T2S0 = Tool without double Threaded rod, **which is to be ordered separately** (see page 57)

FORM 1500/T2S

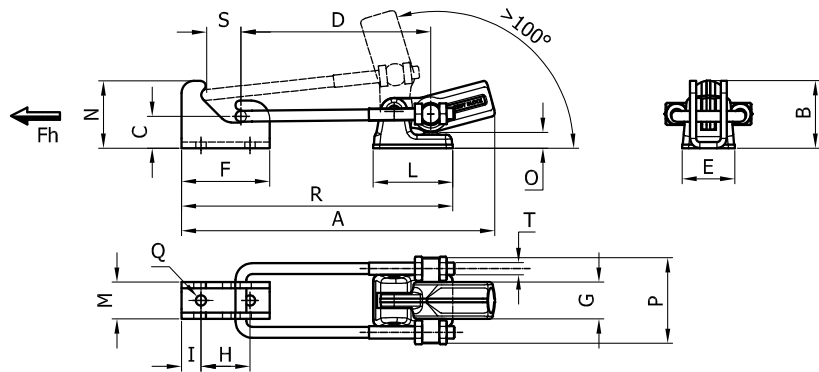

FORM 1510/T2S

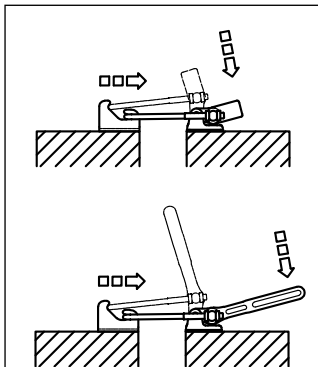
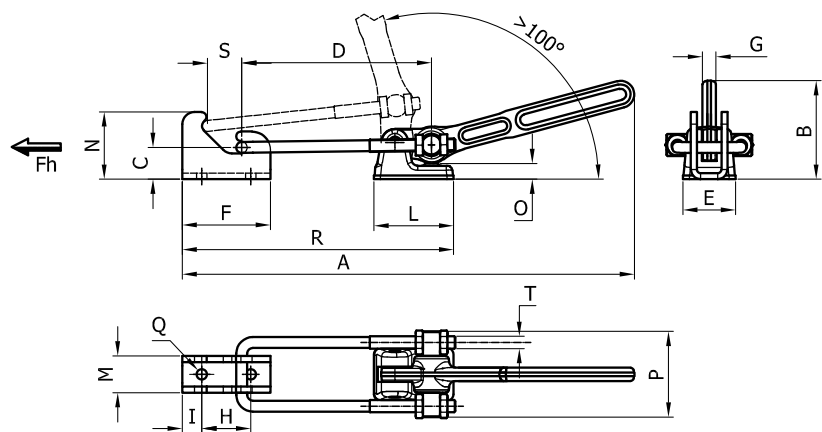

Code	Description	A	B	C	D	E	F	G	H	I	L	M	N	O	P	Q	R	S	T	Fh (daN)	gr.
AL750	1500/T2S	256	55	26	155	43	72	30	40	16	65	30	55	13	70	8,5	222	28	M10	1500	1240
AL755	1510/T2S	369	80,5	26	155	43	72	11	40	16	65	30	55	13	70	8,5	222	28	M10	1500	1320

FORM C

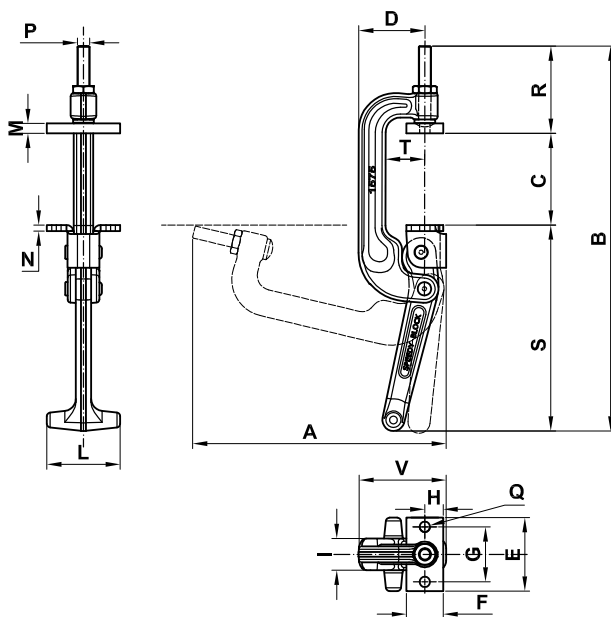

C SERIES FOR HIGH TEMPERATURES

Material:

The sheet metal parts are made from steel;

The other parts are made of hot-stamped weldable steel.

Performance:

The tool comes complete with adjusting screw and bearing plate.

Features and applications:

The tools of this series are generally used in rotational forging, as it is able to operate at high temperatures (240-300°C).

This is made possible thanks to their finish, the interposition of special copper grease between the parts and appropriate tolerances between the couplings.

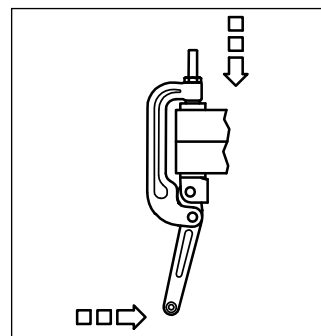

Code	Description	A	B	C	D	E	F	G	H	I	L	M	N	P	Q	R	S	T	V	Fh (daN)	gr.
AL758	1540	173	280	40	54	60	30	45	15	26	60	8	5	M10	8,5	71	169	32	72	1500	1110
AL760	1575	207	315	75	54	60	30	45	15	26	60	8	5	M10	8,5	71	169	32	72	1500	1190



www.speedyblock.com