

METALIKA
COMPONENTS FOR INDUSTRY KACIM



2023 | Catalog | Fueling technology for H₂

WEH[®] H₂ Refueling

High-performance components
for hydrogen vehicles and fueling stations



WEH[®] - We Engineer Hightech

Slovenija
 (+386) 041 694 339
 info@metalika-kacin.com
 Hrvatska
 (+385) 051 213 060
 hrvatska@metalika-kacin.com
 Srbija
 (+381) 011 25 21 756
 srbija@metalika-kacin.com

» Table of contents

1 	H₂ fueling components	6
1.1	Introduction	6
1.2	Overview	8
2 	Products for car fueling stations	10
2.1	Fueling nozzle TK17 H ₂ 70 MPa	10
2.2	Fueling nozzle TK17 H ₂ 70 MPa ENR	14
2.3	Fueling nozzle TK17 H ₂ 35 MPa	18
2.4	Fueling nozzle TK17 H ₂ 35 MPa ENR	22
2.5	Fueling nozzle TK16 H ₂	26
2.6	Fueling nozzle TK16 H ₂ with data interface	30
2.7	Breakaway coupling TSA1 H ₂ 70 MPa	34
2.8	Breakaway coupling TSA1 H ₂	38
2.9	Inline breakaway coupling TSA2 H ₂	46
3 	Products for cars (and fueling stations)	50
3.1	Receptacle TN1 H ₂ 70 MPa	50
3.2	Receptacle TN1 H ₂	54
3.3	Check valve TVR1 H ₂ 70 MPa	58
3.4	Check valve TVR1 H ₂	60
4 	Products for bus and truck fueling stations	62
4.1	Fueling nozzle TK16 H ₂ High-Flow	62
4.2	Fueling nozzle TK16 H ₂ High-Flow with data interface	66
4.3	Fueling nozzle TK25 H ₂	70
4.4	Breakaway coupling TSA5 H ₂	74
4.5	Inline breakaway coupling TSA6 H ₂	78

© All rights reserved, WEH GmbH Verbindungstechnik.
 Any unauthorized copying, distribution or other use of the copyrighted content is strictly forbidden without the written consent of WEH GmbH Verbindungstechnik.
 All previous versions will run out of validity. As a matter of principle the latest up to date transmission of a new version of this document, all previous versions are void for the WEH principle, the latest version of this document is valid on this and for all other WEH products.
 Our General Terms and Conditions and the Agreement on Protection of Know-How and Quality Assurance (www.weh.com) shall apply to deliveries and other services, unless expressly agreed otherwise.
 We do not accept any General Terms and Conditions of the purchaser.
 WEH® is a registered trademark of the WEH GmbH.
 WEH® is a registered trademark of WEH GmbH Verbindungstechnik.

» Table of contents

5 	Products for buses and trucks (and fueling stations)	80
5.1	Receptacle TN1 H ₂ High-Flow	80
5.2	Receptacle TN5 H ₂	84
5.3	Check valve TVR5 H ₂	86
6 	Accessories	88
6.1	Filter TSF2 H ₂	88
6.2	Coalescing filter TSF2 H ₂	92
6.3	Filter TSF4 H ₂	94
6.4	Defueling nozzle TK6 H ₂	96
6.5	Service receptacle TNS10 H ₂	100
6.6	H ₂ Hoses	104
7 	Further information	108
7.1	Technical appendix	108
7.2	Brochure data	111

» Introduction

IMPRESSIONS



WEH® 70 MPa technology: TK17 H₂ 70 MPa fueling nozzle with filling hose and TSA1 H₂ 70 MPa breakaway coupling incl. dispenser mounting

» Introduction

WEH - A RELIABLE PIONEER IN THE HYDROGEN SECTOR

WEH recognized the future of hydrogen as a regenerative energy source at an early stage and developed the first hydrogen refueling components more than 25 years ago. In this sector, WEH set international standards as a pioneer.

Today, hydrogen fueling stations and fuel cell vehicles all over the world are almost entirely equipped with WEH® Refueling components.

Through intensive research and development, WEH has become a reliable partner to the automotive industry. Our products withstand pressures up to 700 bar without any problems.

Today WEH develops, produces and distributes a complete product line for hydrogen refueling. From fueling nozzles, breakaway couplings, hoses and filters at the fueling station to receptacles and check valves in the vehicle. WEH's innovative refueling solutions have led to a much better acceptance in society. The product solutions are a balanced mix of innovation and tradition and ensure that the driver has a familiar refueling experience.

From development to service, our goal is to meet the demands of our customers and the market as a whole with high-quality, safe and user-friendly products. Driven by our passion, intensive research and extensive investments, we continue to work on innovative products for the future market of hydrogen refueling.

Advanced systems for a demanding application

The WEH® Hydrogen product line has been developed to meet the demanding requirements and conditions of high pressure hydrogen refueling systems. All components have been designed to withstand the extreme flow rates and temperature conditions found in practical operations. We use high-quality materials for our products, which are perfectly suited to the respective application.

Test center

Modern, unique testing facilities ensure comprehensive testing of our products from the design phase to series production.

Unique WEH® Jaw locking mechanism

All fueling nozzles are equipped with the jaw locking mechanism specially developed by WEH. The jaws are very resistant to contamination and wear on the vehicle's receptacle is significantly minimized due to the low surface pressure.

Enhanced safety by integrated particle filter

The use of an integrated particle filter prevents the ingress of dirt particles from the outside and therefore leakage at the receptacle is almost eliminated which increases the safety and reliability of our product - Essential features in view of the high requirements in the sector of hydrogen.

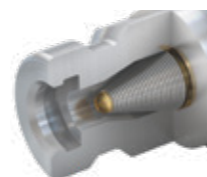

Safely the right decision

Hydrogen refueling can be dangerous if unsuitable products are used.

WEH® Products therefore have a high safety standard to minimize potential risks. Advanced safety features, such as those in the fueling nozzles, are the basis for the use of refueling systems in self-service operations.

» Overview

OVERVIEW FUELING NOZZLES / BREAKAWAY COUPLINGS

And their common uses:

Overview fueling nozzles					
Product family	Page	Car	Bus/truck		
TK17 H ₂ 70 MPa	10	✓			
TK17 H ₂ 70 MPa ENR	14	✓			
TK17 H ₂ 35 MPa	18	✓			
TK17 H ₂ 35 MPa ENR	22	✓			
TK16 H ₂	26	✓			
TK16 H ₂ with data interface	30	✓			
TK16 H ₂ High-Flow	62				✓
TK16 H ₂ High-Flow with data interface	66				✓
TK25 H ₂	70				✓
Overview defueling nozzles					
Product family	Page	Discharging of H ₂ fuel tanks - car			
TK6 H ₂	96				✓
Overview breakaway couplings					
Product family	Page	Car	Car - Inline	Bus/truck	Bus/truck - Inline
TSA1 H ₂ 70 MPa	34	✓			
TSA1 H ₂	38	✓		✓	
TSA2 H ₂	46		✓		✓*
TSA5 H ₂	74			✓	
TSA6 H ₂	78				✓

* except TK16 H₂ / TK16 H₂ High-Flow fueling nozzles with data interface

OVERVIEW FILTERS

Overview filters					
Product family	Page	Car	Bus/truck	Car fueling station	Bus/truck fueling station
TSF2 H ₂	88	✓	✓	✓	✓
TSF2 H ₂ Coalescing	92	✓	✓	✓	✓
TSF4 H ₂	94	✓	✓	✓	✓

» Overview

OVERVIEW PRESSURE RANGE / CODING

All WEH® Fueling nozzles and receptacles have a coding for gas type and the pressure range thus not allowing connection to natural gas vehicles and other pressure ranges. The following connection possibilities are given:

OVERVIEW	Receptacle	TN1 H ₂	TN1 H ₂ TN1 H ₂ for IR*	TN1 H ₂ High-Flow TN1 H ₂ High-Flow for IR*	TN1 H ₂ 70 MPa TN1 H ₂ 70 MPa for IR*	TN5 H ₂
Fueling nozzle	Pressure PN	25 MPa	35 MPa	35 MPa	70 MPa	35 MPa
TK16 H ₂	25 MPa	✓	✓	✓	✓	
TK16 H ₂ TK16 H ₂ IR*	35 MPa		✓	✓	✓	
TK16 H ₂ High-Flow TK16 H ₂ High-Flow IR*	35 MPa			✓	✓	
TK17 H ₂ 35 MPa TK17 H ₂ 35 MPa ENR**	35 MPa		✓	✓	✓	
TK17 H ₂ 70 MPa TK17 H ₂ 70 MPa ENR**	70 MPa				✓	
TK25 H ₂	35 MPa					✓

* IR = with infrared data interface / ** ENR = with exchangeable infrared data interface

INTERNATIONAL STANDARDS AND APPROVALS

The following overview shows the standards for which WEH® Products can be certified. For detailed information see respective product.

- Regulation (EC) No. 79/2009*
- Tests acc. to SAE J2600:2002
- SAE J2799
- SAE J2601
- ATEX
- NEC
- KTL
- CCC

* All products with EC79 approval are also suitable for use in stationary systems.
 When using the products in stationary systems, please check the necessity of a conformity assessment procedure acc. to the Pressure Equipment Directive 2014/68/EU and contact us if corresponding documentation is required.
 Please also refer to the note on page 110, Explanation on the Pressure Equipment Directive.

For reasons of precaution, we'd like to point out that

- regarding the delivery of each article acc. to the respective order confirmation - in particular concerning ECE / EC79 articles - WEH does not confirm the fulfilment of additional requirements of the concerned end customer,
 - WEH is not subject to any external reporting obligation with regard to external change management (see page 110) and
 - WEH does not confirm the replacement of the product in the form of a regular series delivery.
- Exclusions acc. to a) - c) can be agreed with the conclusion of a customer-specific project with corresponding special conditions.

» Overview

CERTIFIED QUALITY MANAGEMENT

Our high quality standards are achieved by a practiced quality management and confirmed by certification according to international quality standards.



Quality Management System
DIN EN ISO 9001:2015



Environmental Management System
DIN EN ISO 14001:2015

MEMBERSHIPS

WEH is a member of the German Hydrogen and Fuel Cell Association and the Hydrogen.Bavaria Center (H2.B).



» Fueling nozzle TK17 H₂ 70 MPa

DESCRIPTION



Features

- Type C nozzle acc. to SAE J2600 resp. ISO 17268
- Left or right single-handed operation
- Compatible with WEH® TN1 H₂ 70 MPa Receptacle profile
- WEH® EASY-TURN 250° swivel joint
- Easy operation
- High flow rate → short filling times
- Protection against impact and cold
- Plastic thermal protection
- Hand grip with magnet
- WEH® Jaw locking mechanism
- High-grade materials
- Coding for pressure range / gas type (acc. to table below)

The WEH® TK17 H₂ 70 MPa Fueling nozzle was developed for fast filling of cars with compressed, gaseous hydrogen (CGH₂). The fueling nozzle with single-handed operation is just as quick and easy to use as the common petrol nozzle and has a similar look and feel.

Simply lift the nozzle from the dispenser mounting and place it onto the vehicle's receptacle. The integrated swivel joint allows a free rotation of the coupling by approx. 250°. Then pull back the actuation lever and the refueling process can begin. The gaseous hydrogen only flows through the line if there is a safe connection. After the refueling process is completed, the fueling nozzle is disconnected by actuating the locking lever. Of course, refueling may be stopped or paused at any time. The hand grip has a magnet for actuation of the magnet switch for activation of the dispenser.

The internal coding for pressure range and gas type ensures that the TK17 H₂ 70 MPa can be connected to the compatible WEH® Receptacles acc. to the opposite table and also prevents the risk of confusion with natural gas.

The WEH® TK17 H₂ 70 MPa offers optimum safety for the operator thanks to the locking mechanism. The fueling nozzle remains connected to the receptacle until the locking mechanism is released by the operator.

Application

Fueling nozzle for hydrogen fast filling of cars at self-service fueling stations.

		TN1 H ₂			
		25 MPa	35 MPa	35 MPa HF*	70 MPa
TK17 H ₂ 70 MPa	70 MPa				✔
	70 MPa				

* HF = High-Flow

TECHNICAL DATA

Characteristics	Basic version
Nominal bore (DN)	4 mm
Pressure range	PN = 70 MPa PS = 87.5 MPa
Media temperature range	-40 °C up to +85 °C
Ambient temperature range	-40 °C up to +85 °C
Material	Corrosion resistant
Sealing material	Hydrogen resistant
Nozzle type	Type C acc. to SAE J2600:2015 and previous resp. ISO 17268:2012 and previous
Design	With plastic thermal protection, cold protection and hand grip with magnet
Weight	Approx. 1.9 kg
Conformity / Tests / Approvals	Tests acc. to SAE J2600:2002

» Fueling nozzle TK17 H₂ 70 MPa

ORDERING | WEH® TK17 H₂ 70 MPa Fueling nozzle

approx. dimensions (mm)

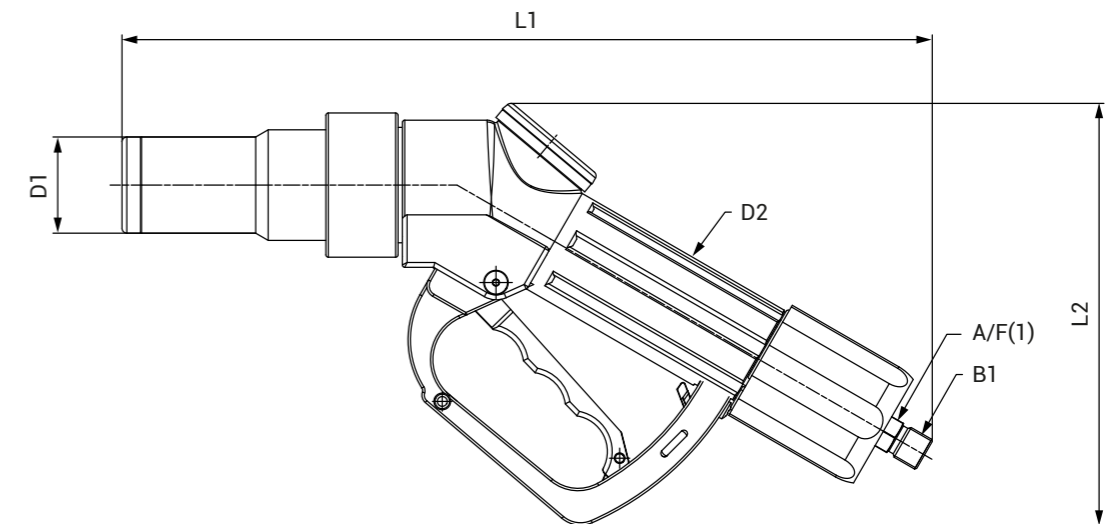

Part no.	Description	Pressure (PS)	B1 (male thread)	L1	L2	D1	D2	A/F(1)
C1-162708	TK17 H ₂ 70 MPa	87.5 MPa	UNF 9/16"-18*	337	175	40	46	14

* 60° inner cone

Fueling assemblies consisting of fueling nozzle, hose set and breakaway coupling are available on request.

ACCESSORIES

The following accessories are available for the WEH® TK17 H₂ 70 MPa Fueling nozzle:

Hose set

Hose set for connecting fueling nozzle and TSA1 H₂ 70 MPa breakaway coupling, complete with filling hose and braided protection hose as cover.

Design filling hose: max. operating pressure PS: 96.25 MPa / nominal bore (DN): 4.5 mm / media temperature range: -40 °C up to +85 °C



Part no.	B1/B2 (female thread)	Hose length
E68-163061	UNF 9/16"-18*	3 m
E68-163062	UNF 9/16"-18*	4 m
E68-163063	UNF 9/16"-18*	5 m

* DKJ 58°

» Fueling nozzle TK17 H₂ 70 MPa

Dispenser mounting

Mounting for safe attachment of the fueling nozzle to the dispenser. Optionally a magnetic field sensor can be installed.

approx. dimensions (mm)

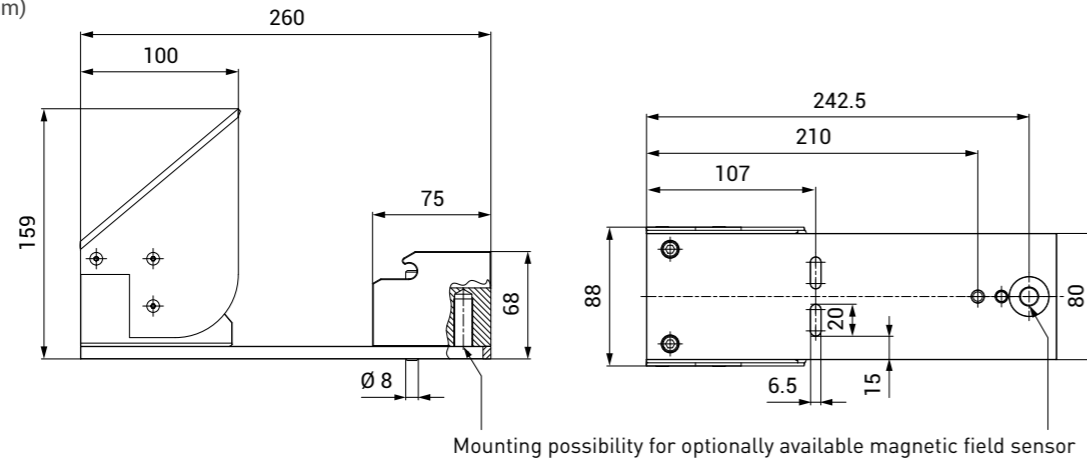

Part no.	Description
C1-143641	Dispenser mounting (switch actuated) with weather protection and special cover for impact protection
E68-123980	Magnetic field sensor with 2 m cable, explosion-proof acc. to ATEX

WEH® TNS1 H₂ Service receptacle

To prevent damage in the fueling nozzle while purging or leak testing during maintenance in the course of which pressure is applied, we recommend the use of a service receptacle. The receptacle also protects the fueling nozzle from dirt ingress whilst not in use.



Part no.	Description
C1-148079	TNS1 H ₂ Service receptacle incl. protection cap

WEH® Breakaway coupling

For the suitable TSA1 H₂ 70 MPa breakaway coupling, please see page 35.

» Fueling nozzle TK17 H₂ 70 MPa

SPARE PARTS

Various parts are available as spares for the WEH® TK17 H₂ 70 MPa Fueling nozzle.



Part No.	Description
E80-80187	① Impact protection
E80-84030	② Locking lever
E69-161748	③ Logo cap
E80-59738	③ Label plate
E80-162272	④ Plastic thermal protection (cold protection)
E99-44923	Maintenance spray

When ordering please specify the part no. engraved on the fueling nozzle.

» Fueling nozzle TK17 H₂ 70 MPa ENR

DESCRIPTION



Features

- Type C nozzle acc. to SAE J2600 resp. ISO 17268
- Left or right single-handed operation
- Compatible with WEH[®] TN1 H₂ 70 MPa Receptacle profile
- Exchangeable data interface (ENR)
- Integrated purging line for nitrogen purging
- Prepared for dispenser mounting with purging system
- WEH[®] EASY-TURN 250° swivel joint
- Increased robustness in case of improper handling
- Easy operation
- High flow rate → short filling times
- Protection against impact and cold
- Plastic thermal protection
- Hand grip with magnet
- WEH[®] Jaw locking mechanism
- High-grade materials
- Coding for pressure range / gas type (acc. to table below)

The WEH[®] TK17 H₂ 70 MPa ENR Fueling nozzle with exchangeable data interface (ENR = exchangeable nozzle receiver) was developed for fast filling of cars with compressed, gaseous hydrogen (CGH₂). The fueling nozzle has the same outstanding features as the already well-known TK17 H₂ 70 MPa.

The TK17 H₂ 70 MPa ENR is additionally equipped with a purging line that allows purging with nitrogen during and after refueling process. This can prevent ingress of moisture and the formation of ice crystals during filling with pre-cooled hydrogen. Removing the fueling nozzle from the receptacle is thus made easier even in unfavorable climatic conditions.

The efficiency of the purging line has been successfully tested in compliance with the Freezing Test 7.26 from the ISO 17268:2020.

The WEH[®] TK17 H₂ 70 MPa ENR offers optimum safety for the operator thanks to the locking mechanism. The fueling nozzle remains connected to the receptacle until the locking mechanism is released by the operator.

Application

Fueling nozzle for hydrogen fast filling of cars at self-service fueling stations.

TECHNICAL DATA

Characteristics	Basic version
Nominal bore (DN)	4 mm
Pressure range	PN = 70 MPa PS = 87.5 MPa
Media temperature range	-40 °C up to +85 °C
Ambient temperature range	-40 °C up to +85 °C
Material	Corrosion resistant
Sealing material	Hydrogen resistant
Nozzle type	Type C acc. to SAE J2600:2015 and previous resp. ISO 17268:2012 and previous
Design	With plastic thermal protection, cold protection, hand grip with magnet, exchangeable data interface acc. to SAE J2799 and integrated purging line
Weight	Approx. 2.9 kg
Medium for purging	Nitrogen
Nominal bore (DN) purging line	4 mm
Media temperature range purging medium	-20 °C up to +85 °C
Flow rate during purging	500 NI/h at max. 12 bar purging pressure
Conformity / Tests / Approvals	Fueling nozzle: tests acc. to SAE J2600:2002 IR data interface: SAE J2799 and ATEX, NEC, KTL or CCC

TK17 H ₂ 70 MPa ENR	TN1 H ₂			
	25 MPa	35 MPa	35 MPa HF*	70 MPa
70 MPa				✔

* HF = High-Flow

» Fueling nozzle TK17 H₂ 70 MPa ENR

ORDERING | WEH[®] TK17 H₂ 70 MPa ENR Fueling nozzle

approx. dimensions (mm)

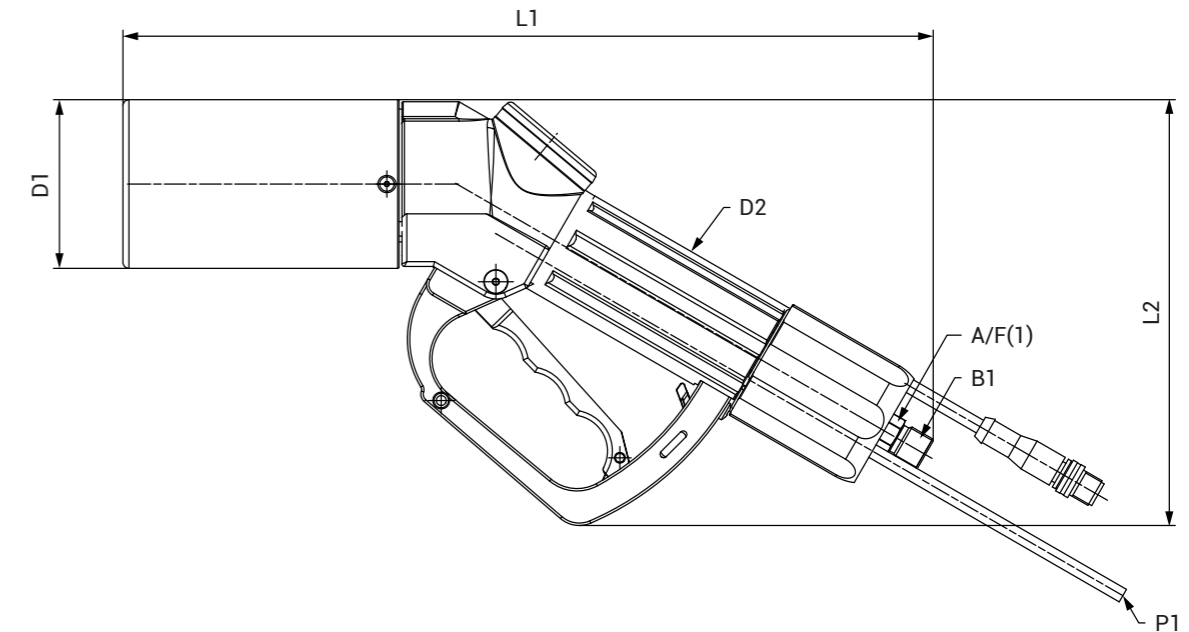

Part no.	Description	Pressure (PS)	B1 (male thread)	P1	L1	L2	D1	D2	A/F(1)
C1-160702-X01	TK17 H ₂ 70 MPa ENR (ATEX IR data interface)	87.5 MPa	UNF 9/16"-18*	Ø 6	339	175	70	46	14
C1-160701-X01	TK17 H ₂ 70 MPa ENR (NEC IR data interface)	87.5 MPa	UNF 9/16"-18*	Ø 6	339	175	70	46	14
C1-164846	TK17 H ₂ 70 MPa ENR (KTL IR data interface)	87.5 MPa	UNF 9/16"-18*	Ø 6	339	175	70	46	14
C1-171177	TK17 H ₂ 70 MPa ENR (CCC IR data interface)	87.5 MPa	UNF 9/16"-18*	Ø 6	339	175	70	46	14

* 60° inner cone

Fueling assemblies consisting of fueling nozzle, hose set and breakaway coupling are available on request.

ACCESSORIES

The following accessories are available for the WEH[®] TK17 H₂ 70 MPa ENR Fueling nozzle:

Hose set

Hose set for connecting fueling nozzle and TSA1 H₂ 70 MPa breakaway coupling, complete with filling hose, data cable, purging line and braided protection hose as cover.

Design filling hose: max. operating pressure PS: 96.25 MPa / nominal bore (DN): 4.5 mm / media temperature range: -40 °C up to +85 °C



Part no.	B1/B2 (female thread)	P1/P2	Hose length
E68-161886	UNF 9/16"-18*	Ø 6	3 m
E68-161887	UNF 9/16"-18*	Ø 6	4 m
E68-161888	UNF 9/16"-18*	Ø 6	5 m

* DKJ 58°



» Fueling nozzle TK17 H₂ 70 MPa ENR

Dispenser mounting

Mounting for safe attachment of the fueling nozzle to the dispenser. The mounting is equipped with a port for purging operations, that allows purging of the fueling nozzle whilst not in use. Optionally a magnetic field sensor can be installed.

approx. dimensions (mm)

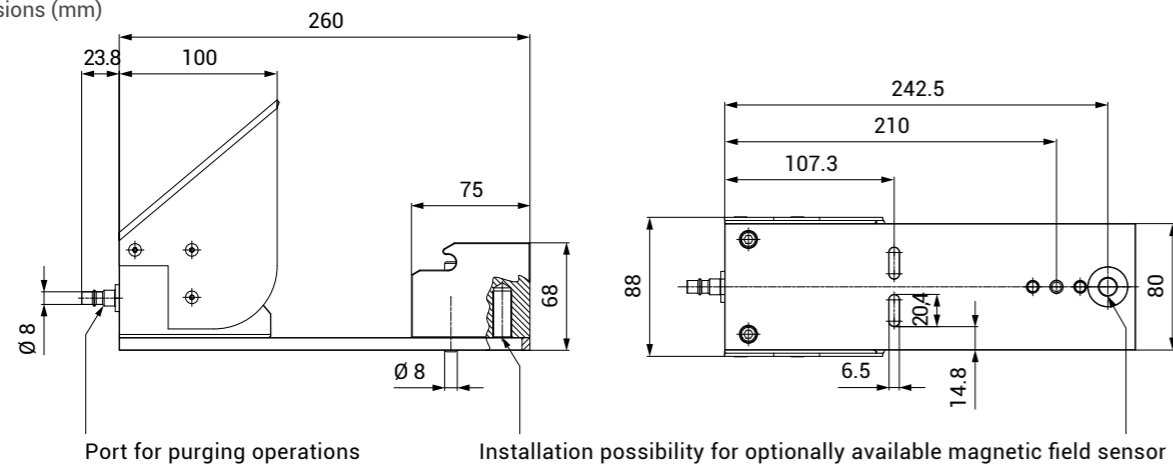

Part no.	Description
C1-122121	Dispenser mounting (switch actuated) with weather protection, special cover for impact protection sleeve and purging system
E68-123980	Magnetic field sensor with 2 m cable, explosion-proof acc. to ATEX

WEH® TNS1 H₂ Service receptacle

To prevent damage in the fueling nozzle while purging or leak testing during maintenance in the course of which pressure is applied, we recommend the use of a service receptacle. The receptacle also protects the fueling nozzle from dirt ingress whilst not in use.



Part no.	Description
C1-148079	TNS1 H ₂ Service receptacle incl. protection cap

WEH® Breakaway coupling

For the suitable TSA1 H₂ 70 MPa breakaway coupling, please see page 36.

Data cable

Part no.	Description	Hose length
E68-96194	Data cable suitable for 4 m hose set	4.45 m
E68-96193	Data cable for connecting with the converter	3.45 m

Other lengths on request

» Fueling nozzle TK17 H₂ 70 MPa ENR

SPARE PARTS

Various parts are available as spares for the WEH® TK17 H₂ 70 MPa ENR Fueling nozzle.



Part No.	Description
W137968	① Impact protection sleeve (incl. 3 countersunk screws)
W137969	② ATEX IR data interface (incl. 3 cylinder screws, 3 countersunk screws and o-ring)
W140915	② NEC IR data interface (incl. 3 cylinder screws, 3 countersunk screws and o-ring)
W166319	② KTL IR data interface (incl. 3 cylinder screws, 3 countersunk screws and o-ring)
W171905	② CCC IR data interface (incl. 3 cylinder screws, 3 countersunk screws and o-ring)
E80-84030	③ Locking lever
E69-161748	④ Logo cap
E80-59738	④ Label plate
E80-162272	⑤ Plastic thermal protection (cold protection)
E69-157491	⑥ Label
E99-44923	Maintenance spray

When ordering please specify the part no. engraved on the fueling nozzle.

» Fueling nozzle TK17 H₂ 35 MPa

DESCRIPTION



Features

- Type C nozzle acc. to SAE J2600 resp. ISO 17268
- Left or right single-handed operation
- Compatible with WEH® TN1 H₂ Receptacle profile
- WEH® EASY-TURN 250° swivel joint
- Easy operation
- High flow rate → short filling times
- Protection against impact and cold
- Plastic thermal protection
- Hand grip with magnet
- WEH® Jaw locking mechanism
- High-grade materials
- Coding for pressure range / gas type (acc. to table below)

The WEH® TK17 H₂ 35 MPa Fueling nozzle was developed for fast filling of cars with compressed, gaseous hydrogen (CGH₂).

It is equipped with the same outstanding features as all other WEH® TK17 H₂ Fueling nozzles:

The integrated swivel joint allows a free rotation of the coupling by approx. 250° and the hand grip has a magnet for actuation of the magnet switch for activation of the dispenser.

The internal coding for pressure range and gas type ensures that the TK17 H₂ 35 MPa can be connected to the compatible WEH® Receptacles acc. to the opposite table and also prevents the risk of confusion with natural gas.

The WEH® TK17 H₂ 35 MPa offers optimum safety for the operator thanks to the locking mechanism. The fueling nozzle remains connected to the receptacle until the locking mechanism is released by the operator.

Application

Fueling nozzle for hydrogen fast filling of cars at self-service fueling stations.

TECHNICAL DATA

Characteristics	Basic version
Nominal bore (DN)	4 mm
Pressure range	PN = 35 MPa PS = 49 MPa
Media temperature range	-40 °C up to +85 °C
Ambient temperature range	-40 °C up to +85 °C
Material	Corrosion resistant
Sealing material	Hydrogen resistant
Nozzle type	Type C acc. to SAE J2600:2015 and previous resp. ISO 17268:2012 and previous
Design	With plastic thermal protection, cold protection and hand grip with magnet
Weight	Approx. 1.8 kg
Conformity / Tests / Approvals	Tests acc. to SAE J2600:2002

		TN1 H ₂			
		25 MPa	35 MPa	35 MPa HF*	70 MPa
TK17 H ₂ 35 MPa	35 MPa		✓	✓	✓
	49 MPa				

* HF = High-Flow

» Fueling nozzle TK17 H₂ 35 MPa

ORDERING | WEH® TK17 H₂ 35 MPa Fueling nozzle

approx. dimensions (mm)

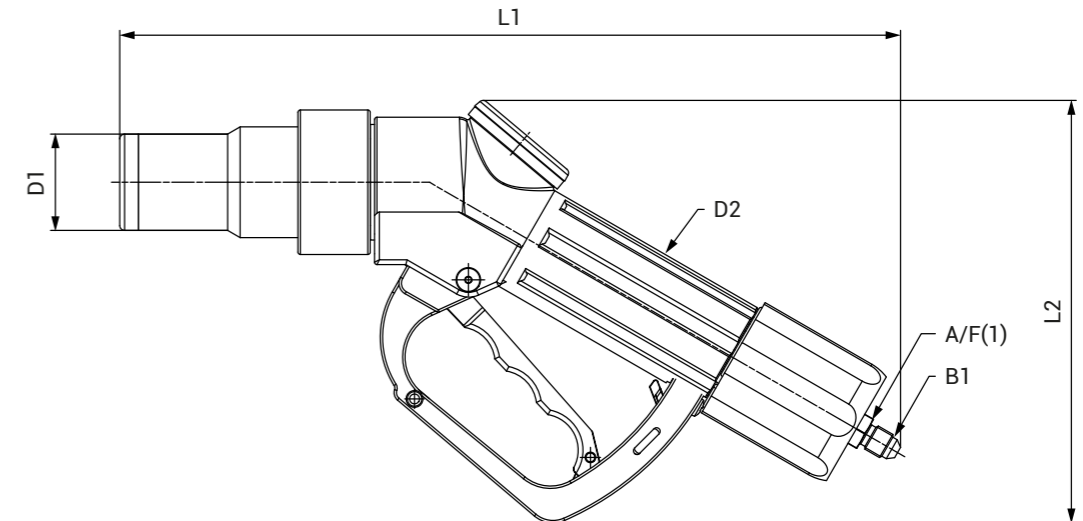

Part no.	Description	Pressure (PS)	B1 (male thread)	L1	L2	D1	D2	A/F(1)
C1-174292	TK17 H ₂ 35 MPa	49 MPa	UNF 7/16"-20*	324	175	40	46	14

* acc. to SAE J514, 37° cone

Fueling assemblies consisting of fueling nozzle, hose set and breakaway coupling are available on request.

ACCESSORIES

The following accessories are available for the WEH® TK17 H₂ 35 MPa Fueling nozzle:

Hose set

Hose set for connecting fueling nozzle and TSA1 H₂ breakaway coupling, complete with filling hose and braided protection hose as cover. Design filling hose: max. operating pressure PS: 49 MPa / nominal bore (DN): 4.5 mm / media temperature range: -40 °C up to +85 °C



Part no.	B1/B2 (female thread)	Hose length
E68-174296	UNF 7/16"-20*	3 m
E68-174297	UNF 7/16"-20*	4 m
E68-174298	UNF 7/16"-20*	5 m

* acc. to SAE JIC, 37° sealing cone

» Fueling nozzle TK17 H₂ 35 MPa

Dispenser mounting

Mounting for safe attachment of the fueling nozzle to the dispenser. Optionally a magnetic field sensor can be installed.

approx. dimensions (mm)

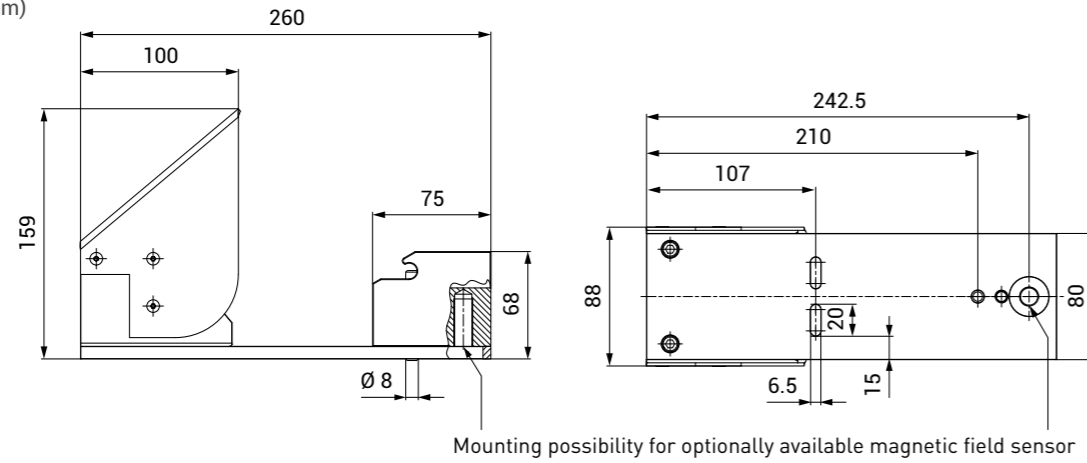

Part no.	Description
C1-143641	Dispenser mounting (switch actuated) with weather protection and special cover for impact protection
E68-123980	Magnetic field sensor with 2 m cable, explosion-proof acc. to ATEX

WEH® TNS1 H₂ Service receptacle

To prevent damage in the fueling nozzle while purging or leak testing during maintenance in the course of which pressure is applied, we recommend the use of a service receptacle. The receptacle also protects the fueling nozzle from dirt ingress whilst not in use.



Part no.	Description
C1-148079	TNS1 H ₂ Service receptacle incl. protection cap

WEH® Breakaway couplings

For the suitable TSA1 H₂ breakaway coupling or TSA2 H₂ inline breakaway coupling, please see page 39 resp. 49.

» Fueling nozzle TK17 H₂ 35 MPa

SPARE PARTS

Various parts are available as spares for the WEH® TK17 H₂ 35 MPa Fueling nozzle.



Part No.	Description
E80-80187	1 Impact protection
E80-84030	2 Locking lever
E69-161748	3 Logo cap
E80-59738	3 Label plate
E80-162272	4 Plastic thermal protection (cold protection)
E99-44923	Maintenance spray

When ordering please specify the part no. engraved on the fueling nozzle.

» Fueling nozzle TK17 H₂ 35 MPa ENR

DESCRIPTION



Features

- Type C nozzle acc. to SAE J2600 resp. ISO 17268
- Left or right single-handed operation
- Compatible with WEH® TN1 H₂ Receptacle profile
- Exchangeable data interface (ENR)
- Integrated purging line for nitrogen purging
- Prepared for dispenser mounting with purging system
- WEH® EASY-TURN 250° swivel joint
- Increased robustness in case of improper handling
- Easy operation
- High flow rate → short filling times
- Protection against impact and cold
- Plastic thermal protection
- Hand grip with magnet
- WEH® Jaw locking mechanism
- High-grade materials
- Coding for pressure range / gas type (acc. to table below)

The WEH® TK17 H₂ 35 MPa ENR Fueling nozzle with exchangeable data interface (ENR = exchangeable nozzle receiver) was developed for fast filling of cars with compressed, gaseous hydrogen (CGH₂).

Equipped with the same outstanding features as the WEH® TK17 H₂ 35 MPa without ENR, the fueling nozzle with ENR also has an interface (infrared) for data transfer between vehicle and fueling station, as well as a purging line for purging the nozzle with nitrogen during and after refueling process. This can prevent ingress of moisture and formation of ice crystals. The internal coding for pressure range and gas type ensures that the TK17 H₂ 35 MPa ENR can be connected to the compatible WEH® Receptacles acc. to the opposite table and also prevents the risk of confusion with natural gas.

The WEH® TK17 H₂ 35 MPa ENR offers optimum safety for the operator thanks to the locking mechanism. The fueling nozzle remains connected to the receptacle until the locking mechanism is released by the operator.

Application

Fueling nozzle for hydrogen fast filling of cars at self-service fueling stations.

TECHNICAL DATA

Characteristics	Basic version
Nominal bore (DN)	4 mm
Pressure range	PN = 35 MPa PS = 49 MPa
Media temperature range	-40 °C up to +85 °C
Ambient temperature range	-40 °C up to +85 °C
Material	Corrosion resistant
Sealing material	Hydrogen resistant
Nozzle type	Type C acc. to SAE J2600:2015 and previous resp. ISO 17268:2012 and previous
Design	With plastic thermal protection, cold protection, hand grip with magnet, exchangeable data interface acc. to SAE J2799 and integrated purging line
Weight	Approx. 2.4 kg
Medium for purging	Nitrogen
Nominal bore (DN) purging line	4 mm
Media temperature range purging medium	-20 °C up to +85 °C
Flow rate during purging	500 NI/h at max. 12 bar purging pressure
Conformity / Tests / Approvals	Fueling nozzle: tests acc. to SAE J2600:2002 IR data interface: SAE J2799 and ATEX, NEC or KTL

TK17 H ₂ 35 MPa ENR	TN1 H ₂			
	25 MPa	35 MPa	35 MPa HF*	70 MPa
35 MPa		✓	✓	✓

* HF = High-Flow

» Fueling nozzle TK17 H₂ 35 MPa ENR

ORDERING | WEH® TK17 H₂ 35 MPa ENR Fueling nozzle

approx. dimensions (mm)

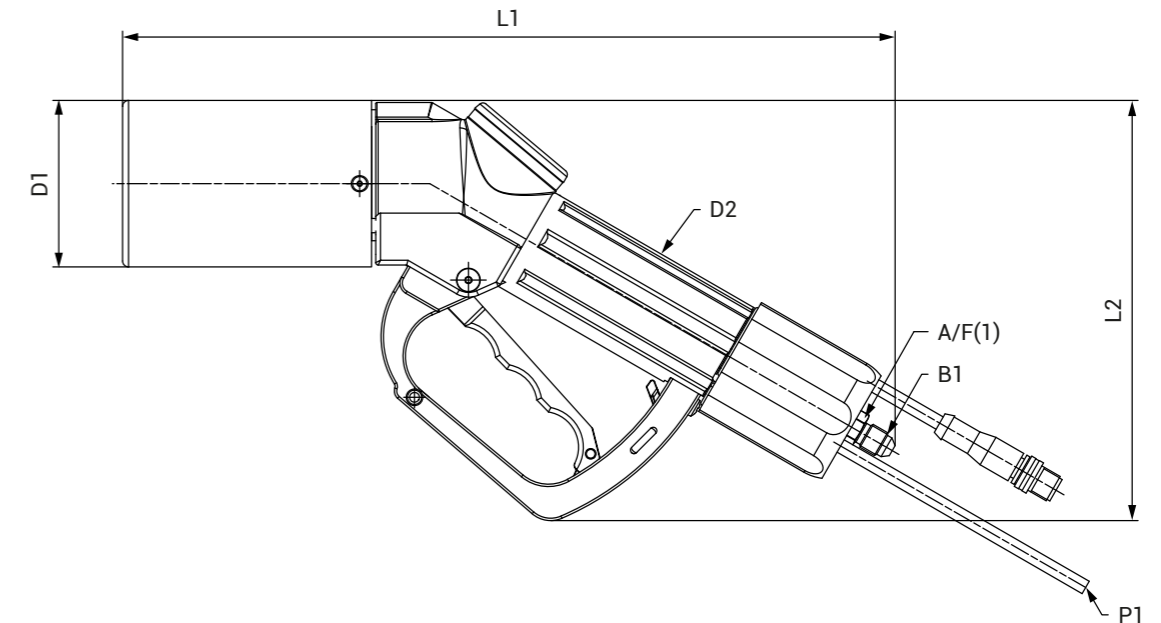

Part no.	Description	Pressure (PS)	B1 (male thread)	L1	L2	D1	D2	A/F(1)
C1-174293	TK17 H ₂ 35 MPa ENR (ATEX IR data interface)	49 MPa	UNF 7/16"-20*	324	177	70	46	14
C1-174294	TK17 H ₂ 35 MPa ENR (NEC IR data interface)	49 MPa	UNF 7/16"-20*	324	177	70	46	14
C1-174295	TK17 H ₂ 35 MPa ENR (KTL IR data interface)	49 MPa	UNF 7/16"-20*	324	177	70	46	14

* acc. to SAE J514, 37° cone

Fueling assemblies consisting of fueling nozzle, hose set and breakaway coupling are available on request.

ACCESSORIES

The following accessories are available for the WEH® TK17 H₂ 35 MPa ENR Fueling nozzle:

Hose set

Hose set for connecting fueling nozzle and TSA1 H₂ breakaway coupling, complete with filling hose, data cable, purging line and braided protection hose as cover.

Design filling hose: max. operating pressure PS: 49 MPa / nominal bore (DN): 4.5 mm / media temperature range: -40 °C up to +85 °C



Part no.	B1/B2 (female thread)	P1/P2	Hose length
E68-174299	UNF 7/16"-20*	∅ 6	3 m
E68-174300	UNF 7/16"-20*	∅ 6	4 m
E68-174301	UNF 7/16"-20*	∅ 6	5 m

* acc. to SAE JIC, 37° sealing cone

» Fueling nozzle TK17 H₂ 35 MPa ENR

Dispenser mounting

Mounting for safe attachment of the fueling nozzle to the dispenser. The mounting is equipped with a port for purging operations, that allows purging of the fueling nozzle whilst not in use. Optionally a magnetic field sensor can be installed.

approx. dimensions (mm)

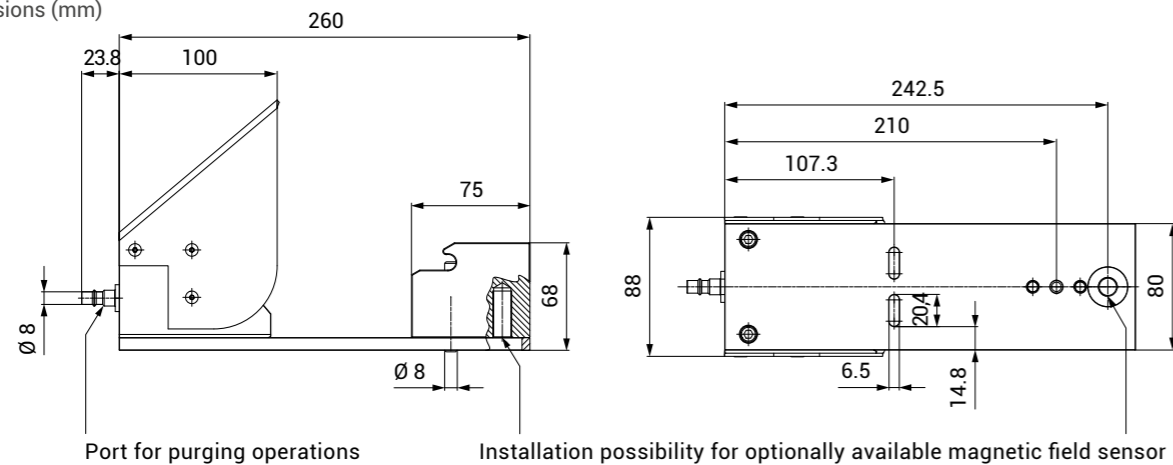

Part no.	Description
C1-122121	Dispenser mounting (switch actuated) with weather protection, special cover for impact protection sleeve and purging system
E68-123980	Magnetic field sensor with 2 m cable, explosion-proof acc. to ATEX

WEH® TNS1 H₂ Service receptacle

To prevent damage in the fueling nozzle while purging or leak testing during maintenance in the course of which pressure is applied, we recommend the use of a service receptacle. The receptacle also protects the fueling nozzle from dirt ingress whilst not in use.



Part no.	Description
C1-148079	TNS1 H ₂ Service receptacle incl. protection cap

WEH® Breakaway couplings

For the suitable TSA1 H₂ breakaway coupling or TSA2 H₂ inline breakaway coupling, please see page 40 resp. 49.

Data cable

Part no.	Description	Hose length
E68-96194	Data cable suitable for 4 m hose set	4.45 m
E68-96193	Data cable for connecting with the converter	3.45 m

Other lengths on request

» Fueling nozzle TK17 H₂ 35 MPa ENR

SPARE PARTS

Various parts are available as spares for the WEH® TK17 H₂ 35 MPa ENR Fueling nozzle.



Part No.	Description
W176899	1 Impact protection sleeve (incl. 3 countersunk screws)
W137969	2 ATEX IR data interface (incl. 3 cylinder screws, 3 countersunk screws and o-ring)
W140915	2 NEC IR data interface (incl. 3 cylinder screws, 3 countersunk screws and o-ring)
W166319	2 KTL IR data interface (incl. 3 cylinder screws, 3 countersunk screws and o-ring)
E80-84030	3 Locking lever
E69-161748	4 Logo cap
E80-59738	4 Label plate
E80-162272	5 Plastic thermal protection (cold protection)
E69-157491	6 Label
E99-44923	Maintenance spray

When ordering please specify the part no. engraved on the fueling nozzle.

» Fueling nozzle TK16 H₂

DESCRIPTION



Features

- Type A acc. to SAE J2600 resp. ISO 17268
- Compatible with WEH[®] TN1 H₂ Receptacle profile
- WEH EASY-TURN[®] 360° swivel joint for actuation lever
- Easy operation
- High flow rate → short filling times
- Recirculation of the vented gas
- Plastic thermal protection
- WEH[®] Jaw locking mechanism
- High-grade materials
- Coding for pressure range / gas type (acc. to table below)

The WEH[®] TK16 H₂ Fueling nozzle makes refueling cars with compressed gaseous hydrogen (CGH₂) so much easier. The TK16 H₂ is very light in weight and therefore easy to operate. The integrated swivel joint is located directly on the actuation lever, making it easy to rotate the fueling nozzle to the optimum connection position. The actuating lever can be switched with little effort when connecting and disconnecting.

The internal coding for pressure range and gas type ensures that the TK16 H₂ can be connected to the compatible WEH[®] Receptacles acc. to the opposite table and also prevents the risk of confusion with natural gas.

The WEH[®] TK16 H₂ offers optimum safety for the operator. The fueling nozzle remains connected to the receptacle until the gas between inlet valve and receptacle is depressurized.

Application

Fueling nozzle for hydrogen fast filling of cars at self-service fueling stations.

		TN1 H ₂			
		25 MPa	35 MPa	35 MPa HF*	70 MPa
TK16 H ₂	25 MPa	✓	✓	✓	✓
	35 MPa		✓	✓	✓

* HF = High-Flow

TECHNICAL DATA

Characteristics	Basic version
Nominal bore (DN)	8 mm
Pressure range	PN = 25 MPa PS = 35 MPa PN = 35 MPa PS = 45 MPa
Media temperature range	-20 °C up to +85 °C
Ambient temperature range	-40 °C up to +85 °C
Material	Corrosion resistant
Sealing material	Hydrogen resistant
Nozzle type	Type A acc. to SAE J2600:2015 and previous resp. ISO 17268:2012 and previous
Design	With plastic thermal protection and gas recirculation
Weight	Approx. 1.8 kg
Conformity / Tests / Approvals	Tests acc. to SAE J2600:2002

Other designs on request

» Fueling nozzle TK16 H₂

ORDERING | WEH[®] TK16 H₂ Fueling nozzle

approx. dimensions (mm)

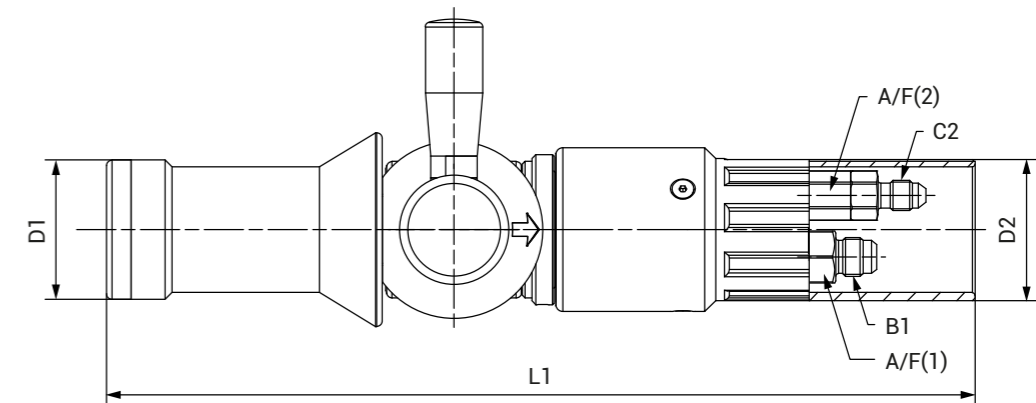

Part No.	Description	Pressure (PS)	B1 (male thread)	C2 (male thread)	L1	D1	D2	A/F(1)	A/F(2)
C1-45695-X4-X01	TK16 H ₂	35 MPa	UNF 9/16"-18*	UNF 7/16"-20*	318	51	52	19	16
C1-45696-X5-X01	TK16 H ₂	45 MPa	UNF 9/16"-18*	UNF 7/16"-20*	318	51	52	19	16

* acc. to SAE J514, 37° cone

Fueling assemblies consisting of fueling nozzle, hose set and breakaway coupling are available on request.

ACCESSORIES

The following accessories are available for the WEH[®] TK16 H₂ Fueling nozzle:

Hose set

Hose set for connecting fueling nozzle and TSA1 H₂ breakaway coupling, complete with filling and venting hose, fittings and press-fittings supported by coil spring stubs. Not suitable for refueling with pre-cooled hydrogen acc. to SAE J2601.

Design filling/venting hose:

max. operating pressure PS: 45 MPa / nominal bore (DN): 4.5 mm / media temperature range: -20 °C up to +90 °C



Part No.	B1/B2 (female thread)	C1/C2 (female thread)	Hose length
C1-60917	UNF 9/16"-18*	UNF 7/16"-20*	3 m
C1-60920	UNF 9/16"-18*	UNF 7/16"-20*	4 m
C1-60923	UNF 9/16"-18*	UNF 7/16"-20*	5 m

* acc. to SAE JIC, 37° cone

» Fueling nozzle TK16 H₂

Dispenser mounting

Mounting for safe attachment of the fueling nozzle to the dispenser.

Part No.	Description
On request	Dispenser mounting

WEH® TNS1 H₂ Service receptacle

To prevent damage in the fueling nozzle while purging or leak testing during maintenance in the course of which pressure is applied, we recommend the use of a service receptacle. The receptacle also protects the fueling nozzle from dirt ingress whilst not in use.



Part no.	Description
C1-148079	TNS1 H ₂ Service receptacle incl. protection cap

WEH® Breakaway couplings

For the suitable TSA1 H₂ breakaway coupling or TSA2 H₂ inline breakaway coupling, please see page 41 - 42 resp. 47.

» Fueling nozzle TK16 H₂

SPARE PARTS

Various parts are available as spares for the WEH® TK16 H₂ Fueling nozzle.



Part No.	Description
E80-176344	1 Impact protection
W72504	2 Actuation lever
E80-163068	3 Cover plate
W136178	4 Protection sleeve (incl. 3 countersunk screws)
E99-44923	Maintenance spray

» Fueling nozzle TK16 H₂ with data interface

DESCRIPTION



Features

- Type A acc. to SAE J2600 resp. ISO 17268
- Compatible with WEH[®] TN1 H₂ Receptacle profile
- Exchangeable data interface (ENR)
- WEH EASY-TURN[®] 240° swivel joint for actuation lever
- Easy operation
- High flow rate → short filling times
- Recirculation of the vented gas
- Plastic thermal protection
- WEH[®] Jaw locking mechanism
- High-grade materials
- Coding for pressure range / gas type (acc. to table below)

With the WEH[®] TK16 H₂, the user has a fueling nozzle for hydrogen that makes refueling cars with compressed gaseous hydrogen (CGH₂) even easier than before. The fueling nozzle with data interface is easy to operate and thus increases operator comfort.

The integrated swivel joint is located directly on the actuation lever, making it easy to rotate the fueling nozzle to the optimum connection position. The actuating lever can be switched with little effort when connecting and disconnecting.

The internal coding for pressure range and gas type ensures that the TK16 H₂ with data interface can be connected to the compatible WEH[®] Receptacles acc. to the opposite table and also prevents the risk of confusion with natural gas. Furthermore, the fueling nozzle has an exchangeable interface (infrared) for data transfer between the vehicle and the fueling station.

The WEH[®] TK16 H₂ with data interface offers optimum safety for the operator. The fueling nozzle remains connected to the receptacle until the gas between inlet valve and receptacle is depressurized.

Application

Fueling nozzle for hydrogen fast filling of cars at self-service fueling stations.

TECHNICAL DATA

Characteristics	Basic version
Nominal bore (DN)	8 mm
Pressure range	PN = 35 MPa PS = 45 MPa
Media temperature range	-20 °C up to +85 °C
Ambient temperature range	-40 °C up to +85 °C
Material	Corrosion resistant
Sealing material	Hydrogen resistant
Nozzle type	Type A acc. to SAE J2600:2015 and previous resp. ISO 17268:2012 and previous
Design	With plastic thermal protection, gas recirculation and data interface acc. to SAE J2799
Weight	Approx. 2.4 kg
Conformity / Tests / Approvals	Fueling nozzle: tests acc. to SAE J2600:2002 IR data interface: SAE J2799 and ATEX, NEC, KTL and CCC

Other designs on request

TK16 H ₂ IR**	TN1 H ₂			
	25 MPa	35 MPa	35 MPa HF*	70 MPa
35 MPa		✓	✓	✓

* HF = High-Flow
** IR = infrared data interface

» Fueling nozzle TK16 H₂ with data interface

ORDERING | WEH[®] TK16 H₂ Fueling nozzle with data interface

approx. dimensions (mm)

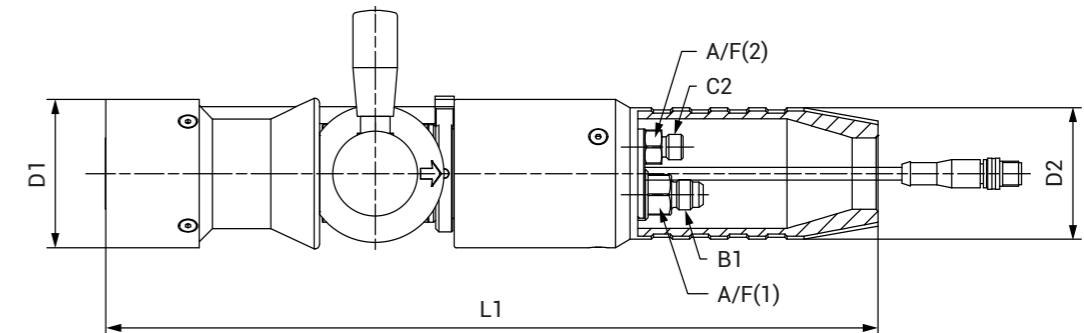

Part No.	Description	Pressure (PS)	B1 (male thread)	C2 (male thread)	L1	D1	D2	A/F(1)	A/F(2)
C1-103471-X01	TK16 H ₂	45 MPa	UNF 9/16"-18*	M12x1.5	364	70	62	19	16

* acc to. SAE J514, 37° cone

Fueling assemblies consisting of fueling nozzle, hose set and breakaway coupling are available on request.

ACCESSORIES

The following accessories are available for the WEH[®] TK16 H₂ Fueling nozzle with data interface:

Hose set

Hose set for connecting fueling nozzle and TSA1 H₂ breakaway coupling, complete with filling and venting hose, hose fittings, plastic spiral hose and cable for data interface. Not suitable for refueling with pre-cooled hydrogen acc. to SAE J2601. Design filling/venting hose: max. operating pressure PS: 45 MPa / nominal bore (DN): 4.5 mm (filling hose) resp. 2 mm (venting hose) / media temperature range: -20 °C up to +90 °C

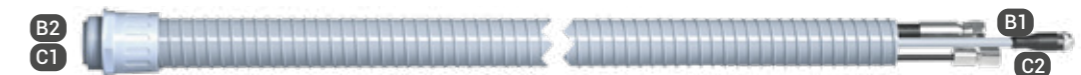

Part No.	B1/B2 (female thread)	C1/C2 (female thread)	Hose length
C1-90698	UNF 9/16"-18*	M12x1.5	3 m
C1-94428	UNF 9/16"-18*	M12x1.5	4 m
C1-94429	UNF 9/16"-18*	M12x1.5	5 m

* acc. to SAE JIC, 37° cone

» Fueling nozzle TK16 H₂ with data interface

Dispenser mounting

Mounting for safe attachment of the fueling nozzle to the dispenser.

Part no.	Description
On request	Dispenser mounting

WEH® TNS1 H₂ Service receptacle

To prevent damage in the fueling nozzle while purging or leak testing during maintenance in the course of which pressure is applied, we recommend the use of a service receptacle. The receptacle also protects the fueling nozzle from dirt ingress whilst not in use.



Part no.	Description
C1-148079	TNS1 H ₂ Service receptacle incl. protection cap

WEH® Breakaway coupling

For the suitable TSA1 H₂ breakaway coupling, please see page 43.

Data cable

Part no.	Description	Hose length
E68-96194	Data cable suitable for 4 m hose set	4.45 m
E68-96193	Data cable for connecting with the converter	3.45 m

Other lengths on request

» Fueling nozzle TK16 H₂ with data interface

SPARE PARTS

Various parts are available as spares for the WEH® TK16 H₂ Fueling nozzle with data interface.



Part No.	Description
W180567	1 Impact protection (incl. 4 countersunk screws)
W180569	2 IR data interface (incl. o-ring and grub screw)
W72504	3 Actuation lever
E80-163068	4 Cover plate
W150340	5 Protection sleeve (incl. 3 countersunk screws)
E99-44923	Maintenance spray

» Breakaway coupling TSA1 H₂ 70 MPa

DESCRIPTION

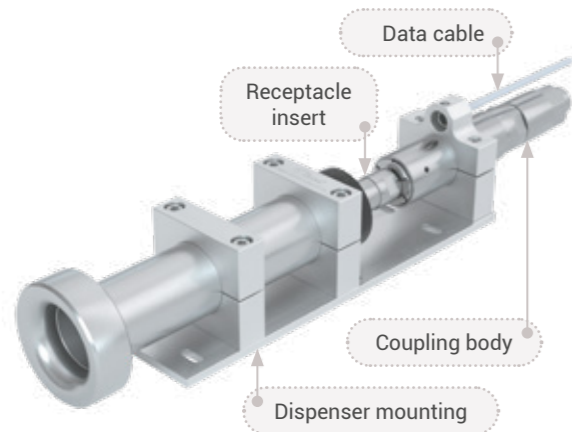

Features

- Reusable without factory servicing
- Installation at the dispenser
- Small compact design
- Integrated cleanable filter (20 µm)
- Incl. dispenser mounting

The WEH[®] TSA1 H₂ 70 MPa Breakaway coupling was specially developed for 700 bar technology. The breakaway is installed directly at the dispenser of the car fueling station.

In the event of unexpected tensile forces, e.g. a vehicle driving away with a connected fueling nozzle, the breakaway separates the connections between dispenser and hose in a controlled manner while sealing both ends. Damage to the vehicle's receptacle, the fueling nozzle and the dispenser can thus be prevented as far as possible. The breakaway coupling can be reused after a functional test. The integrated filter cleans the hydrogen from dirt ingress and can be cleaned easily and quickly during maintenance.

The WEH[®] TSA1 H₂ Breakaway coupling consists of a coupling body, a receptacle insert and a dispenser mounting. The TSA1 H₂ 70 MPa or fueling nozzles with data interface additionally contain a data cable for the data interface.

On request we also offer fueling assemblies consisting of fueling nozzle, hose set and breakaway coupling.

Application

Breakaway coupling for car hydrogen fueling stations for direct installation at the dispenser.

TECHNICAL DATA

Characteristics	Basic version
Nominal bore (DN)	4 mm
Pressure range	PN = 70 MPa PS = 87.5 MPa
Media temperature range	-40 °C up to +85 °C
Ambient temperature range	-40 °C up to +85 °C
Breakaway force	222 - 667 N
Material	Corrosion resistant stainless steel
Sealing material	Hydrogen resistant
Design	With filter (20 µm) and dispenser mounting Incl. data cable (only version for fueling nozzles with data interface)

Other designs on request

» Breakaway coupling TSA1 H₂ 70 MPa

ORDERING | WEH[®] TSA1 H₂ 70 MPa Breakaway coupling for TK17 H₂ 70 MPa

approx. dimensions (mm)

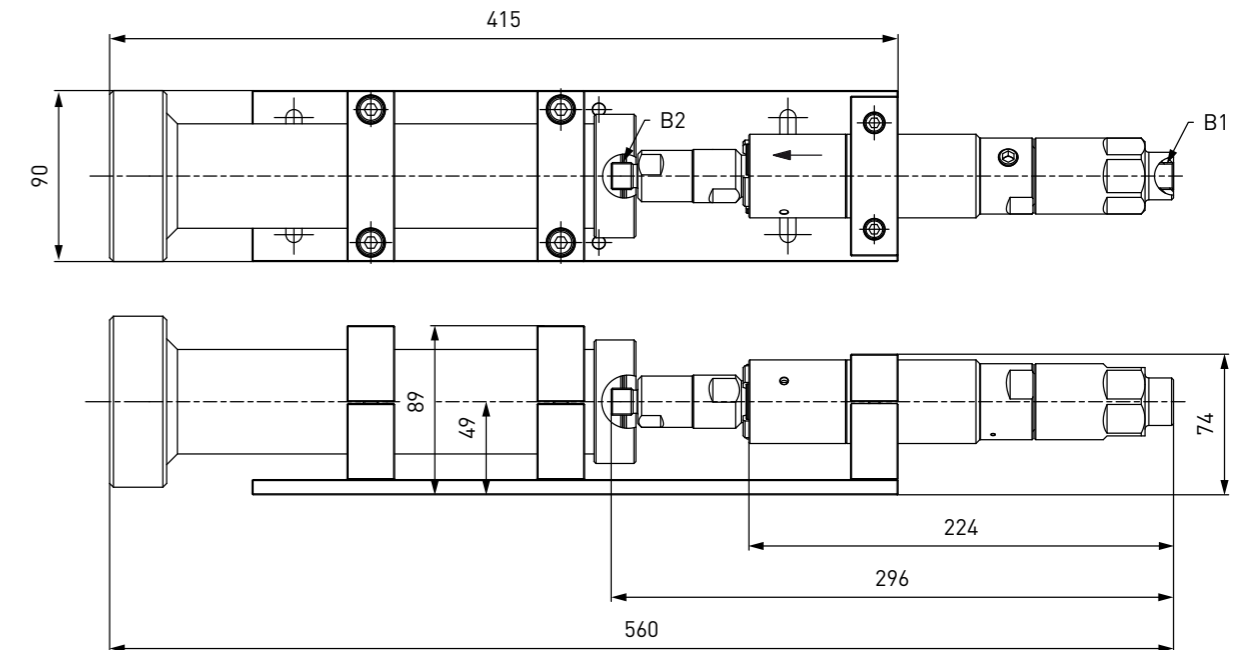

Part No.	Description	DN	Pressure (PS)	B1 (female thread)	B2 (male thread)
C1-93837-X01	TSA1 H ₂ 70 MPa with filter (20 µm)	4	87.5 MPa	UNF 9/16"-18*	UNF 9/16"-18**

* MP-fitting, 60° inner cone
** 60° inner cone

» Breakaway coupling TSA1 H₂ 70 MPa

ORDERING | WEH® TSA1 H₂ 70 MPa Breakaway coupling for TK17 H₂ 70 MPa ENR
approx. dimensions (mm)

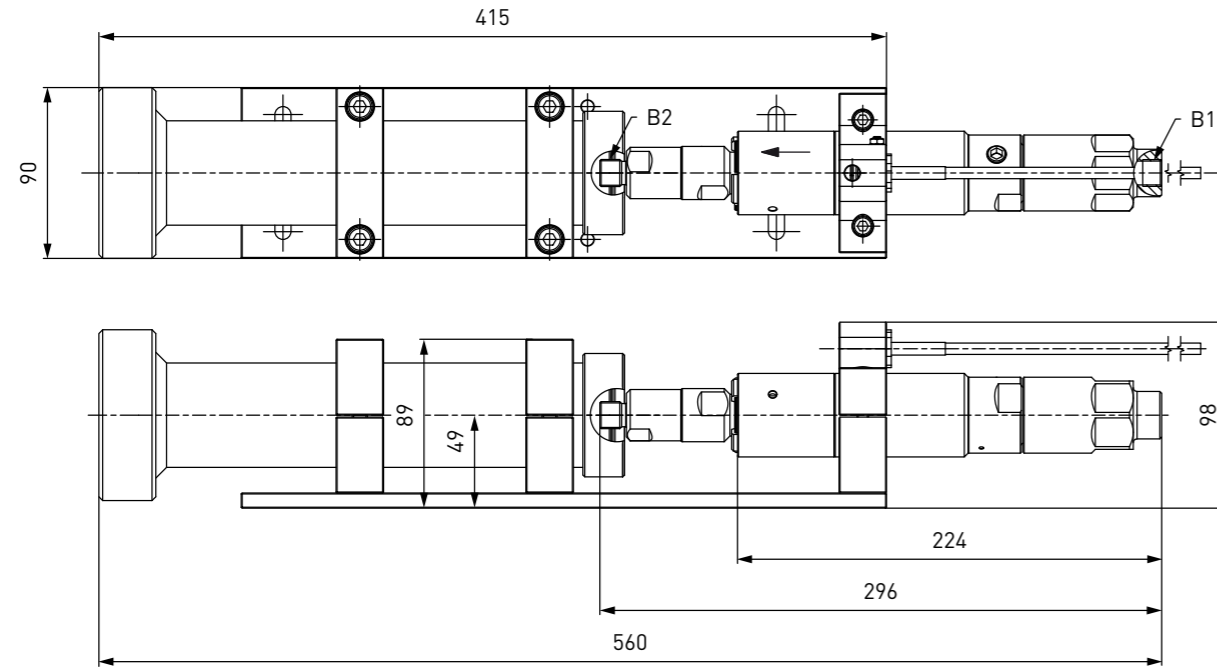

Part No.	Description	DN	Pressure (PS)	B1 (female thread)	B2 (male thread)
C1-96938-X01	TSA1 H ₂ 70 MPa with filter (20 µm)	4	87.5 MPa	UNF 9/16"-18*	UNF 9/16"-18**

* MP-fitting, 60° inner cone
** 60° inner cone

» Breakaway coupling TSA1 H₂ 70 MPa

ACCESSORIES

The following accessories are available for the WEH® TSA1 H₂ 70 MPa Breakaway coupling:

Hoses

Suitable hoses for the TSA1 H₂ 70 MPa breakaway coupling are available on request.

Mounting for braided protection hose

Mounting for attachment of the braided protection hose to the TSA1 H₂ 70 MPa.

Part No.	Description
C1-171845	Mounting for braided protection hose

SPARE PARTS

Various parts are available as spares for the WEH® TSA1 H₂ 70 MPa Breakaway coupling.

Part No.	Description
W92182	Receptacle insert for TSA1 H ₂ 70 MPa
B200B-123477	Spare seals set for receptacle insert W92182
W67754	Wire filter insert 20 µm (incl. spring and o-ring)

» Breakaway coupling TSA1 H₂

DESCRIPTION

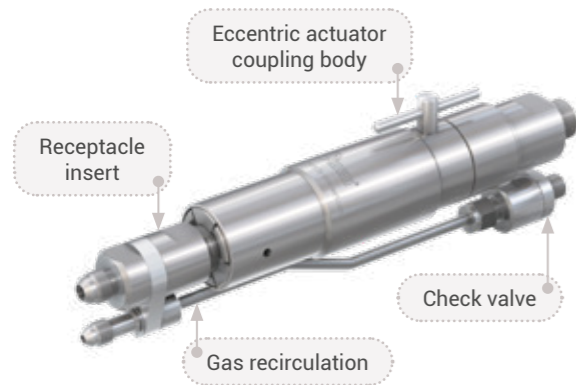

Features

- Reusable without factory servicing
- Installation at the dispenser
- Small compact design
- Version with and without gas recirculation
- Integrated cleanable filter (20 µm or 40 µm)
- Check valve at venting line
- No additional tool necessary

The WEH[®] TSA1 H₂ Breakaway coupling provides additional safety for your car fueling station. The breakaway is installed between the dispenser and the filling hose or dispenser and filling/venting hose.

In the event of unexpected tensile forces, e.g. a vehicle driving away with a connected fueling nozzle, the breakaway separates the connections between dispenser and hose(s) in a controlled manner while sealing both ends. Damage to the vehicle's receptacle, the fueling nozzle and the dispenser can thus be prevented as far as possible. The breakaway coupling can be reused after a functional test.

The integrated filter cleans the hydrogen from dirt ingress and can be cleaned easily and quickly during maintenance.

The WEH[®] TSA1 H₂ Breakaway coupling consists of a coupling body, a receptacle insert and, depending on the version, of a gas recirculation with check valve.

The TSA1 H₂ for fueling nozzles with data interface additionally contain a dispenser mounting incl. data cable for the data interface.

On request we also offer fueling assemblies consisting of fueling nozzle, hose set and breakaway coupling.

Application

Breakaway coupling for car hydrogen fueling stations for direct installation at the dispenser.

TECHNICAL DATA

Characteristics	Basic version
Nominal bore (DN)	Depending on design
Pressure range	PN = 35 MPa PS = 45 MPa
Media temperature range	TSA1 H ₂ for TK17 H ₂ fueling nozzles: -40 °C up to +85 °C TSA1 H ₂ for TK16 H ₂ fueling nozzles: -20 °C up to +85 °C
Ambient temperature range	-40 °C up to +85 °C
Breakaway force	222 - 667 N
Material	Corrosion resistant stainless steel, aluminum
Sealing material	Hydrogen resistant
Design	Depending on design: With filter (20 µm or 40 µm) With or without gas recirculation With or without dispenser mounting With dispenser mounting and data cable (only versions for fueling nozzles with data interface)

Other designs on request

» Breakaway coupling TSA1 H₂

ORDERING | WEH[®] TSA1 H₂ Breakaway coupling (with dispenser mounting) for TK17 H₂ 35 MPa

approx. dimensions (mm)

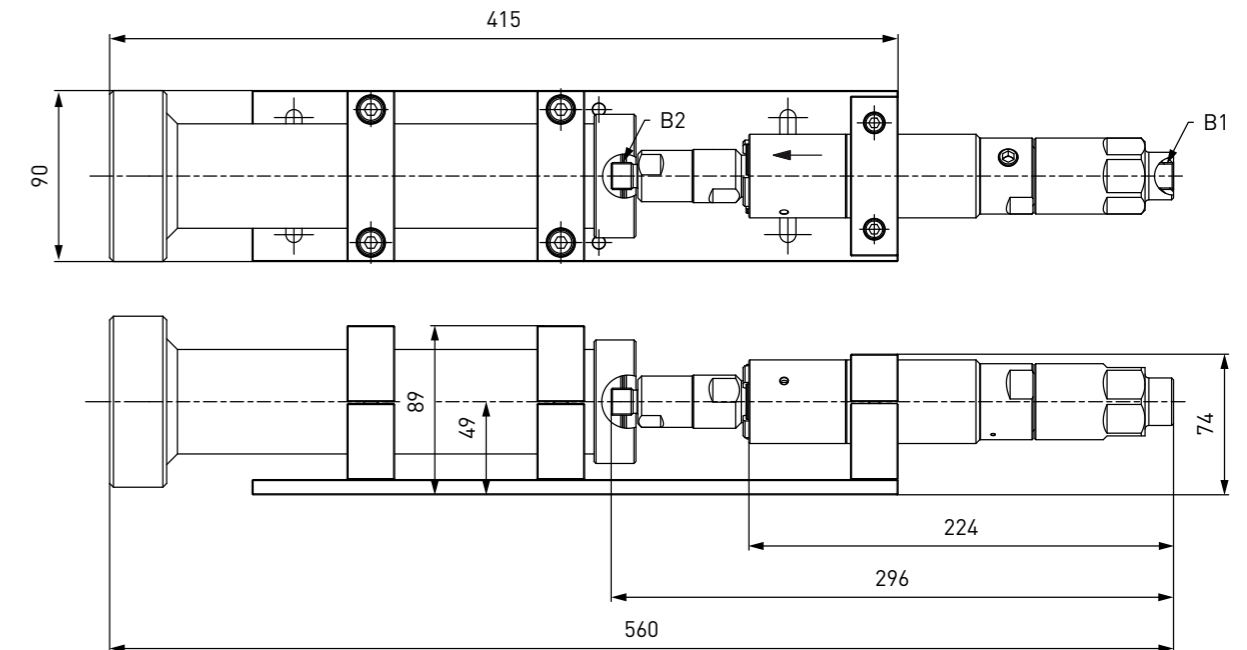

Part No.	Description	DN	Pressure (PS)	B1 (female thread)	B2 (male thread)
C1-174446	TSA1 H ₂ with filter (20 µm)	4	49 MPa	UNF 9/16"-18*	UNF 7/16"-20**

* MP-fitting, 60° inner cone
** acc. to SAE J514, 37° cone

ORDERING | WEH[®] TSA1 H₂ Breakaway coupling for TK17 H₂ 35 MPa

approx. dimensions (mm)

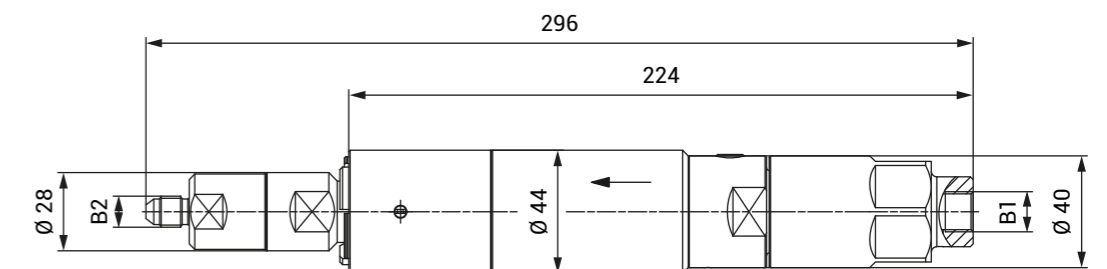

Part No.	Description	DN	Pressure (PS)	B1 (female thread)	B2 (male thread)
C1-174444	TSA1 H ₂ with filter (20 µm)	4	49 MPa	UNF 9/16"-18*	UNF 7/16"-20**

* MP-fitting, 60° inner cone
** acc. to SAE J514, 37° cone

» Breakaway coupling TSA1 H₂

ORDERING | WEH® TSA1 H₂ Breakaway coupling for TK17 H₂ 35 MPa ENR
approx. dimensions (mm)

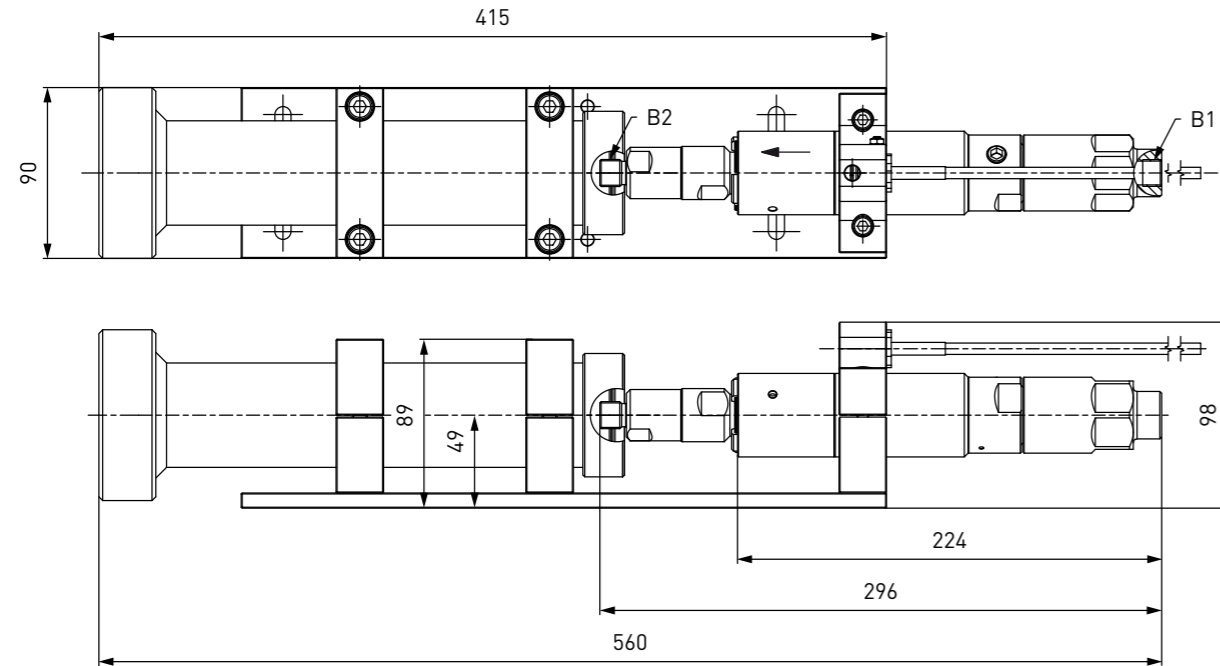

Part No.	Description	DN	Pressure (PS)	B1 (female thread)	B2 (male thread)
C1-174456	TSA1 H ₂ with filter (20 µm)	4	49 MPa	UNF 9/16"-18*	UNF 7/16"-20**

* MP-fitting, 60° inner cone
** acc. to SAE J514, 37° cone

» Breakaway coupling TSA1 H₂

ORDERING | WEH® TSA1 H₂ Breakaway coupling with male thread for TK16 H₂ + High-Flow
approx. dimensions (mm)

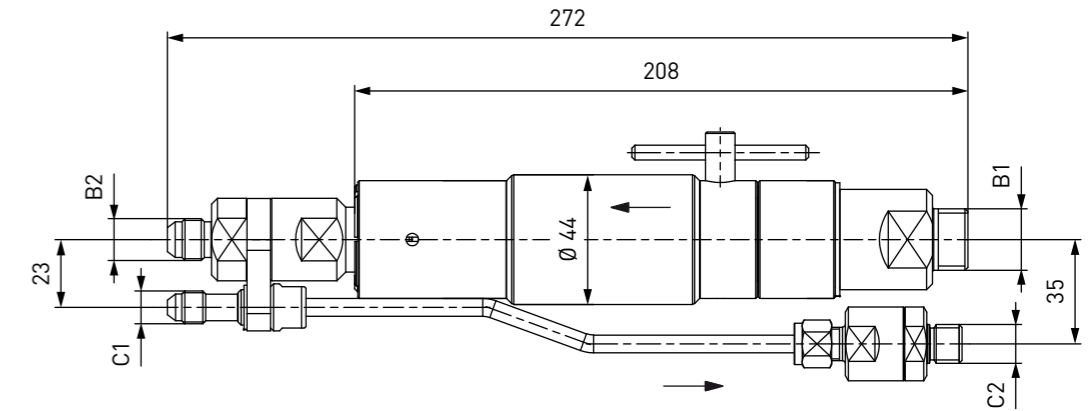

Part No.	Description	DN	Pressure (PS)	B1 (male thread)	B2 (male thread)	C1 (male thread)	C2 (male thread)
C1-18834-X7-X01	TSA1 H ₂ with filter (40 µm)	8	45 MPa	G1/2**	UNF 9/16"-18**	UNF 7/16"-20**	G1/4**
C1-67741-X1-X01	TSA1 H ₂ with filter (20 µm)	8	45 MPa	G1/2**	UNF 9/16"-18**	UNF 7/16"-20**	G1/4**

* acc. to DIN EN ISO 228-1
** acc. to SAE J514, 37° cone

ORDERING | WEH® TSA1 H₂ Breakaway coupling with female thread for TK16 H₂ + High-Flow
approx. dimensions (mm)

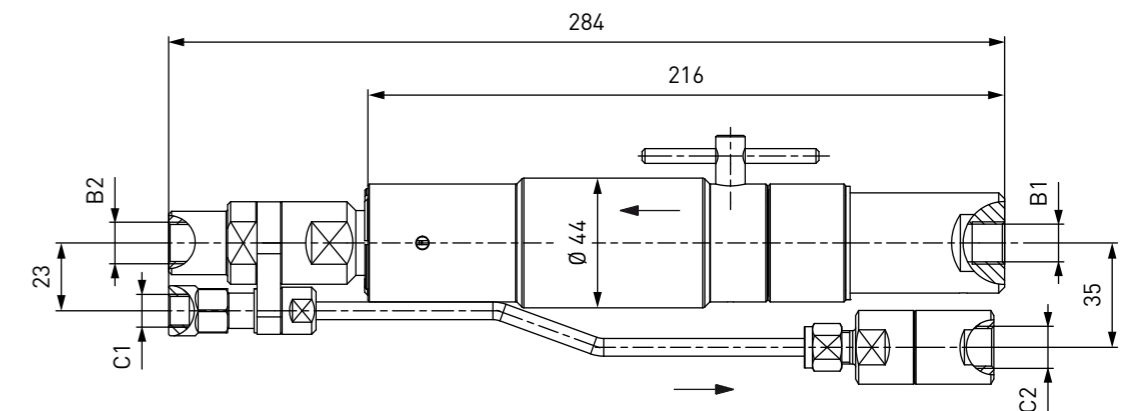

Part No.	Description	DN	Pressure (PS)	B1/B2 (female thread)	C1 (female thread)	C2 (female thread)
C1-99345-X01	TSA1 H ₂ with filter (40 µm)	5	45 MPa	UNF 9/16"-18*	UNF 7/16"-20*	UNF 9/16"-18*

* MP-fitting, 60° inner cone

» Breakaway coupling TSA1 H₂

ORDERING | WEH® TSA1 H₂ Breakaway coupling (with dispenser mounting) for TK16 H₂ + High-Flow
approx. dimensions (mm)

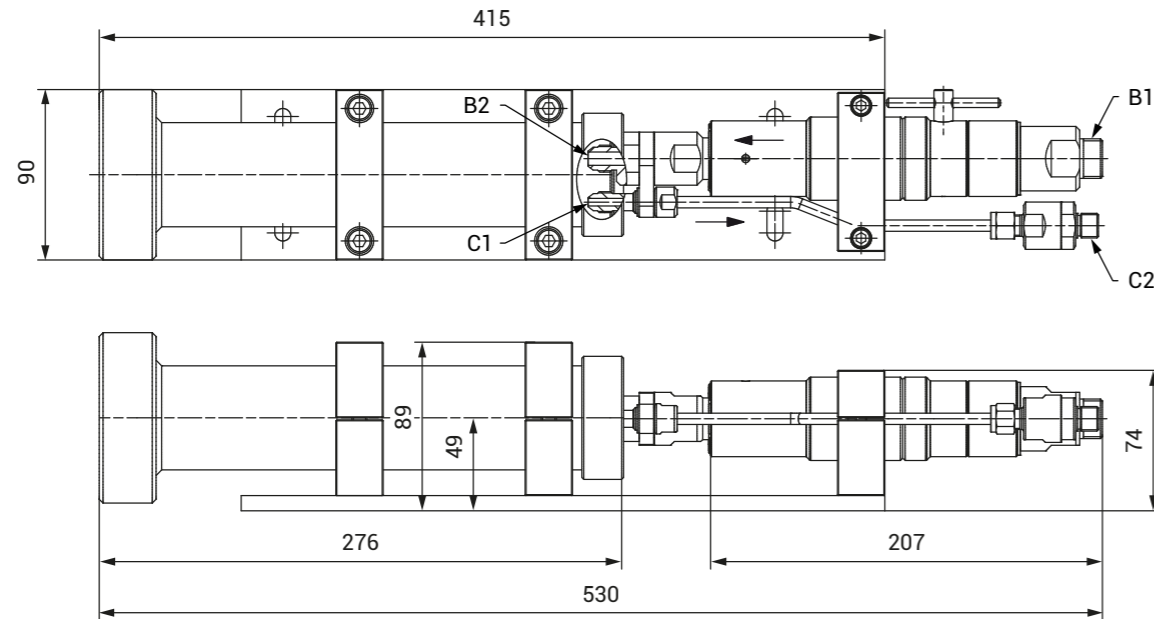

Part No.	Description	DN	Pressure (PS)	B1 (male thread)	B2 (male thread)	C1 (male thread)	C2 (male thread)
C1-129553-X01	TSA1 H ₂ with filter (40 µm)	8	45 MPa	G1/2**	UNF 9/16"-18**	UNF 7/16"-20**	G1/4**
C1-150775-X01	TSA1 H ₂ with filter (20 µm)	8	45 MPa	G1/2**	UNF 9/16"-18**	UNF 7/16"-20**	G1/4**

* acc. to DIN EN ISO 228-1
** acc. to SAE J514, 37° cone

» Breakaway coupling TSA1 H₂

ORDERING | WEH® TSA1 H₂ Breakaway coupling for TK16 H₂ with data interface + High-Flow
approx. dimensions (mm)

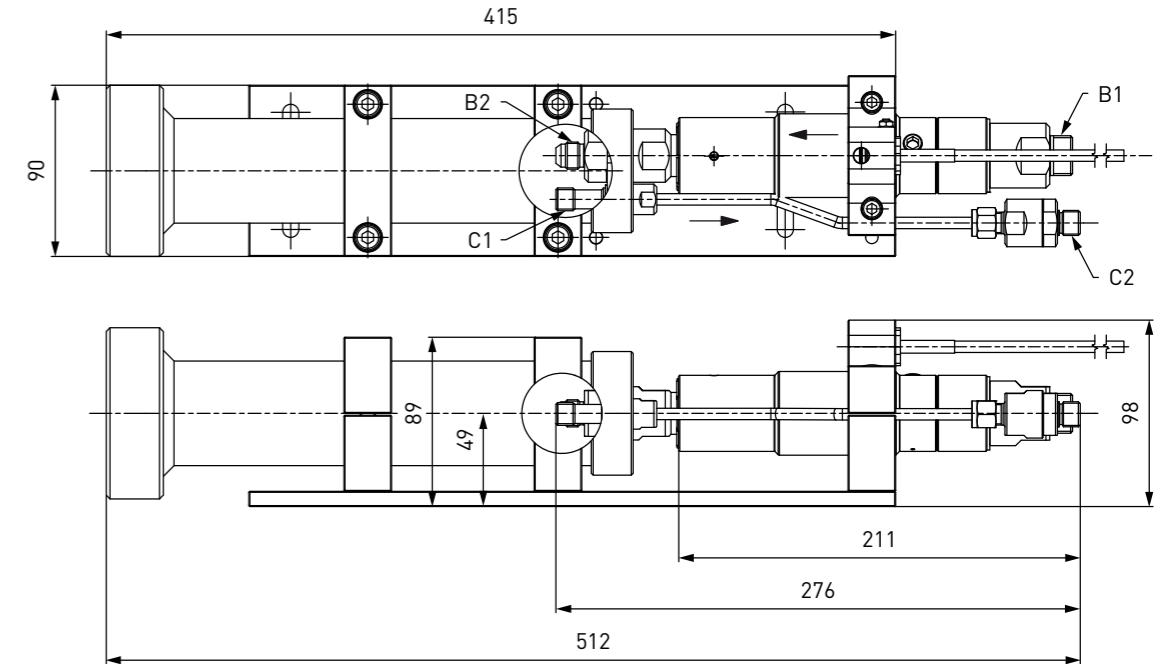

Part No.	Description	DN	Pressure (PS)	B1 (male thread)	B2 (male thread)	C1 (male thread)	C2 (male thread)
C1-90679-X01	TSA1 H ₂ with filter (40 µm)	8	45 MPa	G1/2**	UNF 9/16"-18**	M12x1.5***	G1/4**

* acc. to DIN EN ISO 228-1
** acc. to SAE J514, 37° cone
*** 24° inner cone

» Breakaway coupling TSA1 H₂

ACCESSORIES

The following accessories are available for the WEH® TSA1 H₂ Breakaway coupling:

Dispenser mounting

The breakaway coupling can also be used with a dispenser mounting. The mounting is firmly attached to the dispenser. The integrated guide tube provides a straight pull-off force.

Dispenser mounting for fueling nozzles without data interface
 approx. dimensions (mm)

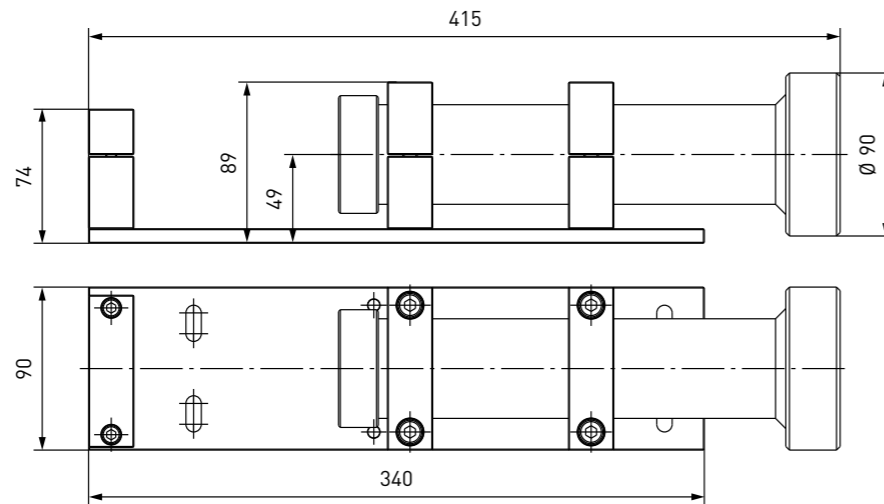

Part No.	Description
C1-69275	Dispenser mounting for TSA1 H ₂ for fueling nozzles TK16 H ₂ without data interface
C1-93824	Dispenser mounting for TSA1 H ₂ for fueling nozzles TK17 H ₂ without data interface

Hoses

Suitable hoses for the TSA1 H₂ breakaway coupling are available on request.

Mounting for braided protection hose

Mounting for attachment of the braided protection hose to the TSA1 H₂ without gas recirculation.

Part No.	Description
C1-171845	Mounting for braided protection hose (suitable for C1-174444, C1-174446, C1-174456)

» Breakaway coupling TSA1 H₂

SPARE PARTS

Various parts are available as spares for the WEH® TSA1 H₂ Breakaway coupling.

Part No.	Description
W159176	Receptacle insert for TSA1 H ₂ without gas recirculation (C1-174444, C1-174446, C1-174456)
W94249	Receptacle insert for TSA1 H ₂ with gas recirculation (C1-18834-X7-X01, C1-67741-X1-X01)
W108401	Receptacle insert for TSA1 H ₂ with gas recirculation (C1-99345-X01)
W108154	Receptacle insert for TSA1 H ₂ with gas recirculation (C1-90679-X01)
B200B-123477	Spare seals set for receptacle insert W159176
B200B-119056	Spare seals set for receptacle insert W94249, W108401, W108154
W139032	Spare parts set consisting of a gas recirculation tube (length: approx. 195 mm) and a firmly mounted check valve (C1-18834-X7-X01, C1-67741-X1-X01, C1-90679-X01)
W140024	Spare parts set consisting of a gas recirculation tube (length: approx. 195 mm) and a firmly mounted check valve (C1-99345-X01)
E69-9061	Wire filter insert 40 µm (incl. spring and o-ring)
W67754	Wire filter insert 20 µm (incl. spring and o-ring)

» Inline breakaway coupling TSA2 H₂

DESCRIPTION

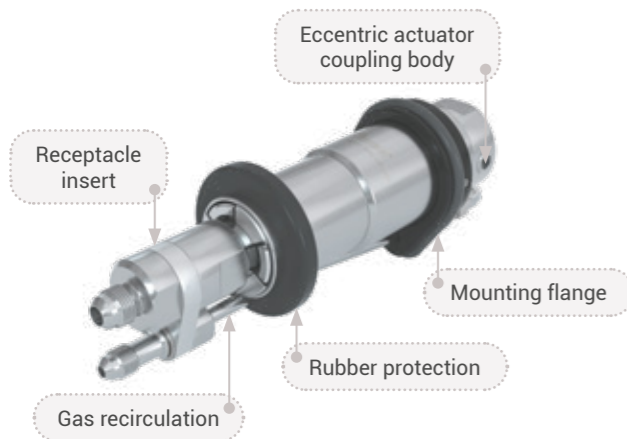

Features

- Reusable without factory servicing
- Installation between the filling and venting hoses
- Small compact design
- Rubber protection and mounting flange incl. impact protection
- Eccentric actuation via Allen wrench

With the WEH[®] TSA2 H₂ Breakaway coupling, an inline breakaway coupling is also available for car refueling stations which is installed between the filling and venting hoses.

In the event of unexpected tensile forces, e.g. a vehicle driving away with a connected fueling nozzle, the breakaway separates the connections between dispenser and hoses in a controlled manner while sealing both ends. Damage to the vehicle's receptacle, the fueling nozzle and the dispenser can thus be prevented as far as possible. The breakaway coupling can be reused after a functional test.

The WEH[®] Breakaway coupling consists of a coupling body, a receptacle insert and a gas recirculation.

When using a TSA2 H₂ inline breakaway coupling, we additionally recommend the WEH[®] TSF2 H₂ Filter (see page 90). The filter protects the breakaway coupling and fueling nozzle from dirt ingress.

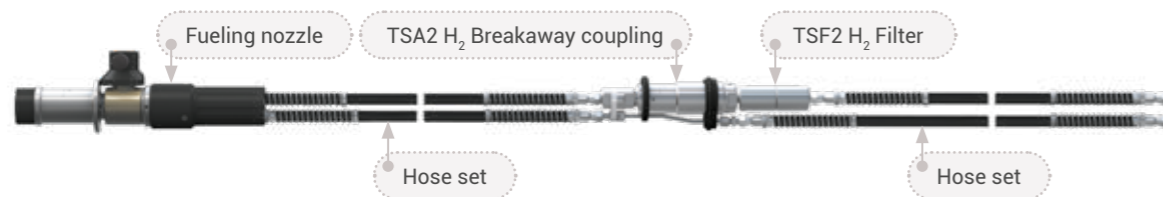

On request we also offer fueling assemblies consisting of fueling nozzle, hose set and inline breakaway coupling.

Application

Inline breakaway coupling for car hydrogen fueling stations for installation between the filling and venting hoses.

TECHNICAL DATA

Characteristics	Basic version
Nominal bore (DN)	8 mm
Pressure range	PN = 35 MPa PS = 45 MPa
Media temperature range	-20 °C up to +85 °C
Ambient temperature range	-40 °C up to +85 °C
Breakaway force	222 - 667 N
Material	Corrosion resistant stainless steel, aluminum
Sealing material	Hydrogen resistant
Design	With gas recirculation

Other designs on request

» Inline breakaway coupling TSA2 H₂

ORDERING | WEH[®] TSA2 H₂ Inline breakaway coupling for TK16 H₂ (+ High-Flow)

approx. dimensions (mm)

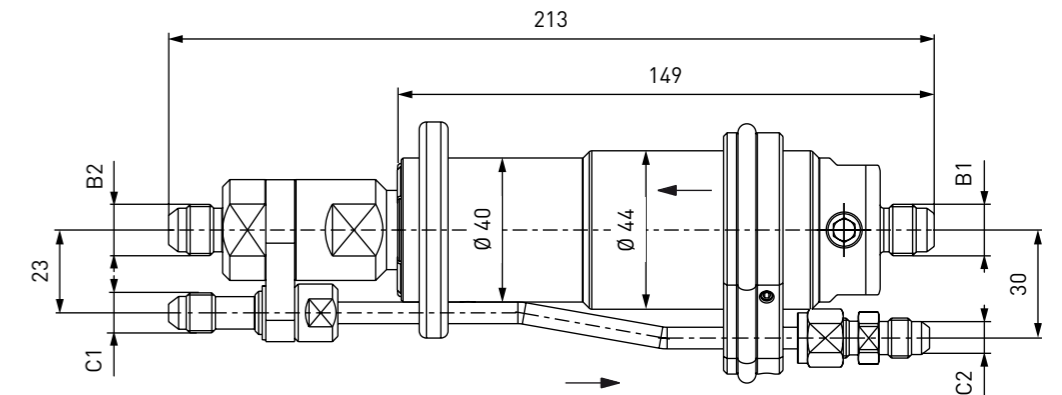

Part No.	Description	DN	Pressure (PS)	B1/B2 (male thread)	C1/C2 (male thread)
C1-77240-X01	TSA2 H ₂	8	45 MPa	UNF 9/16"-18*	UNF 7/16"-20*

* acc. to SAE J514, 37° cone

» Inline breakaway coupling TSA2 H₂

ACCESSORIES

The following accessories are available for the WEH® TSA2 H₂ Inline breakaway coupling:

WEH® TSF2 H₂ Filter

When using a TSA2 H₂ inline breakaway coupling, we additionally recommend the WEH® TSF2 H₂ Filter (see page 90). The filter protects the breakaway coupling and fueling nozzle from dirt ingress. The TSF2 H₂ is installed as a prefilter in the media inlet between the inline breakaway coupling and the filling hose.

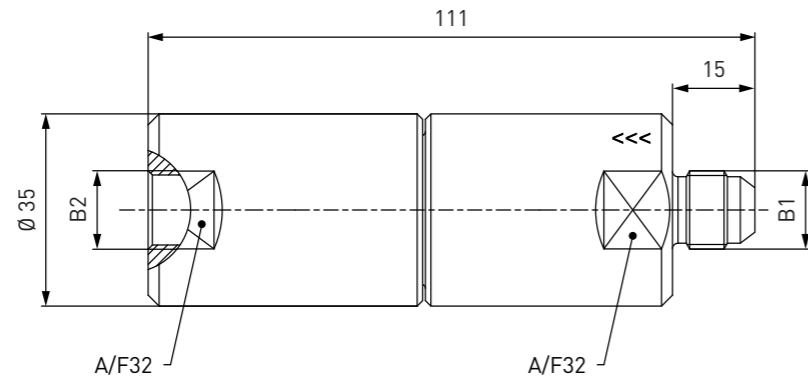

Part No.	Description	Filter (µm)	DN	Pressure (PS)	B1 (male thread)	B2 (female thread)
C1-134710-X01	TSF2 H ₂	40	8	45 MPa	UNF 9/16"-18*	UNF 9/16"-18*
C1-134711-X01	TSF2 H ₂	20	8	45 MPa	UNF 9/16"-18*	UNF 9/16"-18*

* acc. to SAE J514, 37° cone

Hoses

Suitable hoses for the TSA2 H₂ inline breakaway coupling are available on request.

» Inline breakaway coupling TSA2 H₂

SPARE PARTS

Various parts are available as spares for the WEH® TSA2 H₂ Inline breakaway coupling.

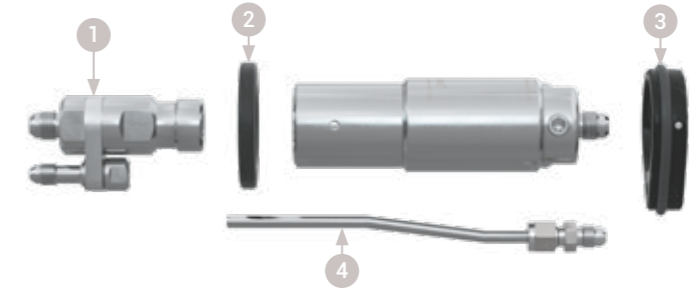

Part No.	Description
W94249	1 Receptacle insert for TSA2 H ₂
B200B-119056	Spare seals set for receptacle insert W94249
E80-71324	2 Front rubber protection
W150599	3 Mounting flange incl. impact protection
W139030	4 Spare part sets consisting of a gas recirculation tube and a firmly mounted fitting

» Receptacle TN1 H₂ 70 MPa

DESCRIPTION



Features

- Low-noise refueling
- Integrated self-cleaning particle filter (20 µm)
- Integrated high-flow check valve
- Sealing-friendly design
- Coding for pressure range / gas type (acc. to table below)

For refueling cars with hydrogen at a pressure range of 700 bar, the WEH[®] TN1 H₂ 70 MPa Receptacle is available. Due to the aerodynamic design of the internal shapes of the receptacle, noise during refueling process is mostly eliminated, while at the same time maximum flow rate is enabled. The internal seals are arranged to largely prevent damage to the sealing components. That is why the WEH[®] TN1 H₂ 70 MPa proves to be extremely robust and durable, minimizing downtimes due to low maintenance.

The receptacle is equipped with an integrated check valve and has a coding for pressure range / gas type.

Enhanced safety by integrated particle filter

The use of an integrated particle filter prevents the ingress of dirt particles from the outside and therefore leakage at the receptacle is almost eliminated.

Application

Receptacle for hydrogen refueling / filling of cars and fork-lift trucks or other industrial applications, to be used with WEH[®] Fueling nozzles acc. to opposite table.

TK17 H ₂ / TK16 H ₂	TK17 H ₂ / TK16 H ₂			
	25 MPa	35 MPa	35 MPa HF*	70 MPa
TN1 H ₂ 70 MPa	✓	✓	✓**	✓

* HF = High-Flow
** except TK16 H₂ High-Flow

TECHNICAL DATA

Characteristics	Basic version
Nominal bore (DN)	3 mm
Pressure range	PN = 70 MPa PS = 87.5 MPa
Temperature range	-40 °C up to +85 °C
Material	Corrosion resistant
Sealing material	Hydrogen resistant
Design	With protection cap, with integrated particle filter (20 µm) and integrated check valve
Conformity / Tests / Approvals	CE 00 0010 (Regulation (EC) No. 79/2009) Tests acc. to SAE J2600:2002 SAE J2799 GB/T 26779-2021

Other designs on request

» Receptacle TN1 H₂ 70 MPa

ORDERING | WEH[®] TN1 H₂ 70 MPa Receptacle with male thread

approx. dimensions (mm)

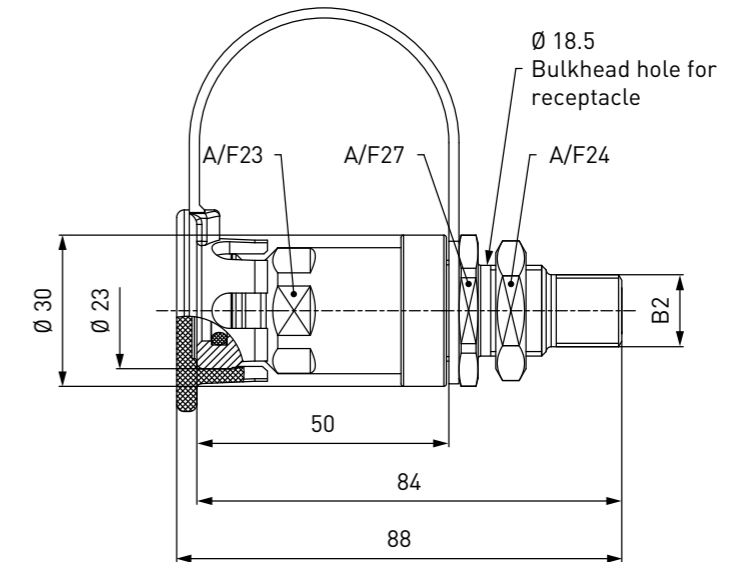

Part No.	Description	DN	Pressure (PS)	B2 (male thread)
C1-84087	TN1 H ₂ 70 MPa (EC79)	3	87.5 MPa	UNF 9/16"-18 for sealing with O-Lok [®] Face Seal* for tube Ø 6 (1/4")

* Face Seal acc. to SAE J1453

ORDERING | WEH[®] TN1 H₂ 70 MPa Receptacle with female thread (autoclave)

approx. dimensions (mm)

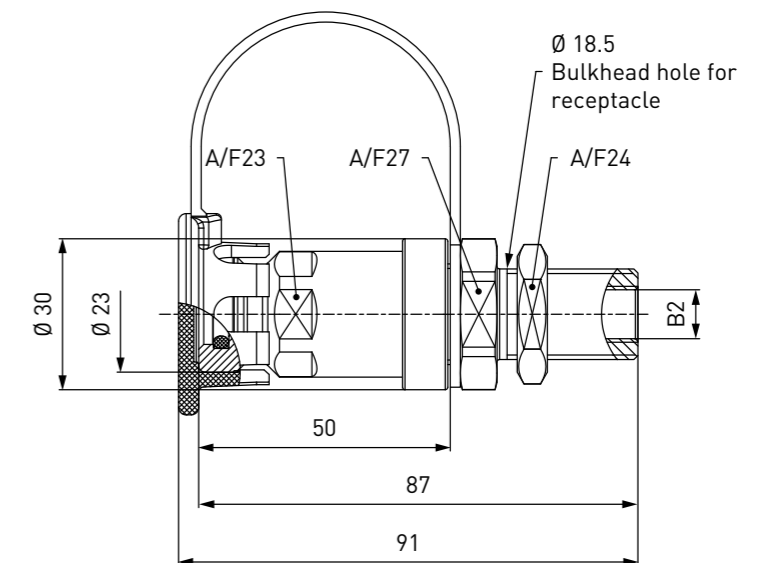

Part No.	Description	DN	Pressure (PS)	B2 (female thread)
C1-87745	TN1 H ₂ 70 MPa (EC79)	3	87.5 MPa	UNF 7/16"-20*

* MP-fitting, 60° inner cone

» Receptacle TN1 H₂ 70 MPa

ORDERING | WEH® TN1 H₂ 70 MPa Receptacle with male thread (autoclave)

approx. dimensions (mm)

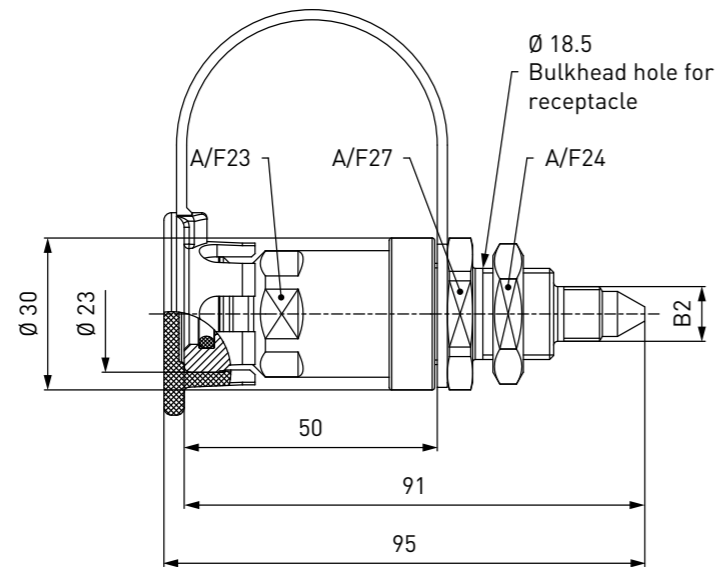

Part No.	Description	DN	Pressure (PS)	B2 (male thread)
C1-88565	TN1 H ₂ 70 MPa (EC79)	3	87.5 MPa	UNF 7/16"-20*

* 60° outer cone

» Receptacle TN1 H₂ 70 MPa

ORDERING | WEH® TN1 H₂ 70 MPa Receptacle with male thread, prepared for data interface

approx. dimensions (mm)

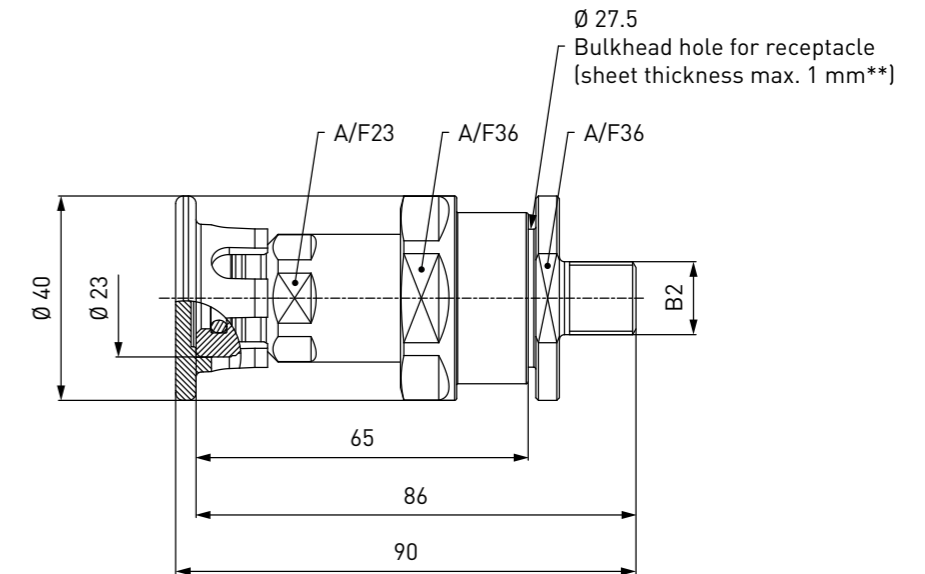

Part No.	Description	DN	Pressure (PS)	B2 (male thread)
C1-84883	TN1 H ₂ 70 MPa (EC79)	3	87.5 MPa	UNF 9/16"-18 for sealing with O-Lok® Face Seal* for tube Ø 6 (1/4")

* Face Seal acc. to SAE J1453

** Please indicate when ordering if thicker sheet metals are needed!

Data interface not included!

Other connection sizes and types (e.g. Cone and Thread Fittings or VOSSLok⁴⁰) on request.

SPARE PARTS

Various parts are available as spares for the WEH® TN1 H₂ 70 MPa Receptacle.

Protection cap

Protection cap with a strap to protect the receptacle from dirt ingress.

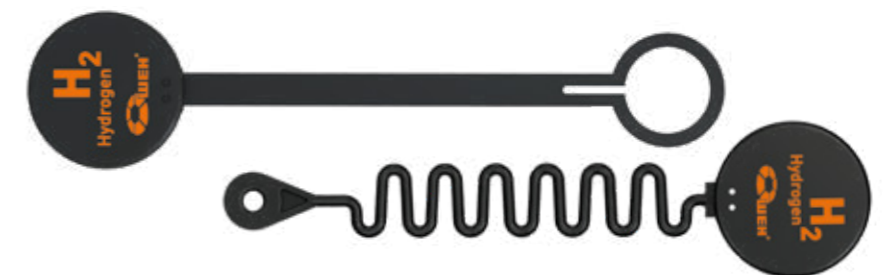

Part No.	Description
W87803	Protection cap
W85984	Protection cap for receptacles prepared for data interface

» Receptacle TN1 H₂

DESCRIPTION



Features

- Low-noise refueling
- Version with and without integrated self-cleaning particle filter (40 µm or 50 µm)
- Integrated high-flow check valve
- Sealing-friendly design
- Coding for pressure range / gas type (acc. to table below)

The WEH[®] TN1 H₂ Receptacle was specially designed for refueling cars with hydrogen. Due to the aerodynamic design of the internal shapes of the receptacle, noise during refueling process is mostly eliminated, while at the same time maximum flow rate is enabled. The internal seals are arranged to largely prevent damage to the sealing components. That is why the WEH[®] TN1 H₂ proves to be extremely robust and durable, minimizing downtimes due to low maintenance.

The receptacle is equipped with an integrated check valve and has a coding for pressure range / gas type.

Enhanced safety by integrated particle filter

The use of an integrated particle filter prevents the ingress of dirt particles from the outside and therefore leakage at the receptacle is almost eliminated.

Application

Receptacle for hydrogen refueling / filling of cars and fork-lift trucks or other industrial applications, to be used with WEH[®] Fueling nozzles acc. to opposite table.

		TK17 H ₂ / TK16 H ₂			
		25 MPa	35 MPa	35 MPa HF*	70 MPa
TN1 H ₂	25 MPa	✓			
	35 MPa	✓	✓		

* HF = High-Flow

TECHNICAL DATA

Characteristics	Basic version
Nominal bore (DN)	8 mm
Pressure range	PN = 25 MPa PS = 35 MPa PN = 35 MPa PS = 45 MPa
Temperature range	-40 °C up to +85 °C
Material	Corrosion resistant
Sealing material	Hydrogen resistant
Design	With protection cap, with integrated particle filter (40 µm or 50 µm), integrated check valve and fittings (only for receptacles with tube fitting)
Conformity / Tests / Approvals	EN 100 0008 (Regulation (EC) No. 79/2009) Leak tests acc. to SAE J2600:2002 GB/T 26779-2021 (only applies to EC79 articles)

Other designs on request

» Receptacle TN1 H₂

ORDERING | WEH[®] TN1 H₂ Receptacle with tube fitting and filter (50 µm)

approx. dimensions (mm)

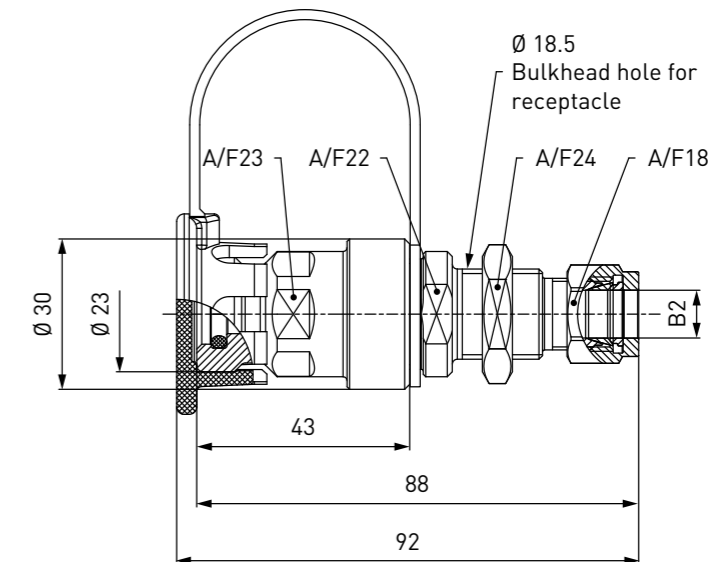

Part No.	Description	DN	Pressure (PS)	B2
C1-31315-X1-X01	TN1 H ₂	8	35 MPa	Tube Ø 3/8"
C1-31316	TN1 H ₂ (EC79)	8	45 MPa	Tube Ø 3/8"
C1-70661-X01	TN1 H ₂	8	35 MPa	Tube Ø 10*
C1-35426	TN1 H ₂ (EC79)	8	45 MPa	Tube Ø 10*

* double ferrule fitting

» Receptacle TN1 H₂

ORDERING | WEH® TN1 H₂ Receptacle prepared for data interface, with filter (40 µm)

approx. dimensions (mm)

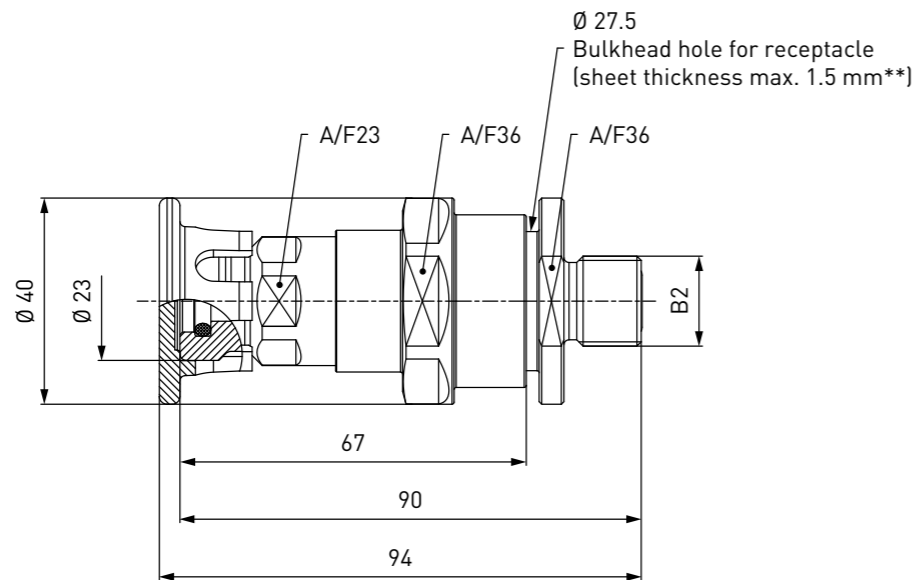

Part No.	Description	DN	Pressure (PS)	B2 (male thread)
C1-85965	TN1 H ₂ (EC79)	8	45 MPa	UN 11/16"-16 for sealing with O-Lok® Face Seal* or tube Ø 10 (3/8")

* Face Seal acc. to SAE J1453

** Please indicate when ordering if thicker sheet metals are needed!
Data interface and fittings not included!

Other connection sizes and types (e.g. Cone and Thread Fittings or VOSSLok⁴⁰) on request.

» Receptacle TN1 H₂

SPARE PARTS

Various parts are available as spares for the WEH® TN1 H₂ Receptacle.

Protection cap

Protection cap with a strap to protect the receptacle from dirt ingress.

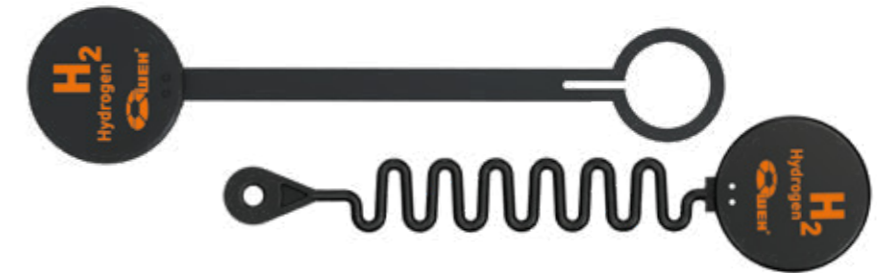

Part No.	Description
W87803	Protection cap
W85984	Protection cap for receptacles prepared for data interface

» Check valve TVR1 H₂ 70 MPa

DESCRIPTION



Features

- Robust construction
- Low-noise opening and closing
- Corrosion resistant stainless steel
- High leak tightness

With the TVR1 H₂ 70 MPa WEH offers a high-performance check valve for use in hydrogen cars or hydrogen fueling stations of the latest generation.

The seals in the valve are arranged to prevent them from being damaged by dirt particles in the gas flow. The WEH[®] TVR1 H₂ 70 MPa Check valve is made of corrosion-resistant stainless steel achieving a very durable unit due to its robust internal structure.

Application

Check valve for cars, also suitable for installation in hydrogen fueling stations.

TECHNICAL DATA

Characteristics	Basic version
Nominal bore (DN)	Depending on design
Pressure range	PN = 70 MPa PS = 87.5 MPa
Temperature range	-40 °C up to +85 °C
Material	Corrosion resistant stainless steel
Sealing material	Hydrogen resistant
Design	With or without integrated particle filter (20 µm)
Conformity / Tests / Approvals	e 1 00 0009 (Regulation (EC) No. 79/2009)

Other designs on request

» Check valve TVR1 H₂ 70 MPa

ORDERING | WEH[®] TVR1 H₂ 70 MPa Check valve with male thread on both sides (Face Seal on both sides)

approx. dimensions (mm)

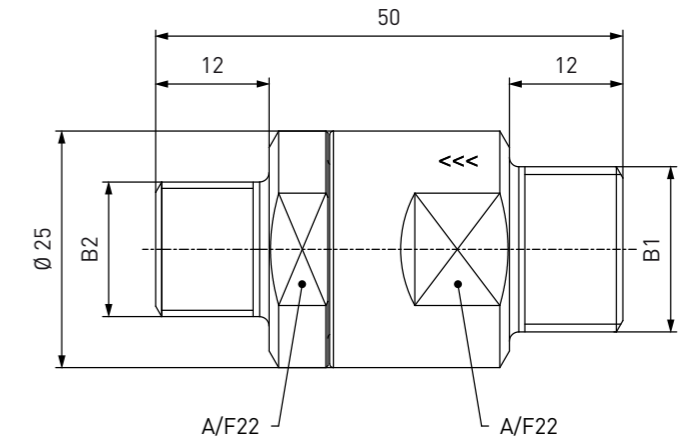

Part No.	Description	DN	Pressure (PS)	B1 (male thread)	B2 (male thread)
C1-76959	TVR1 H ₂ 70 MPa (EC79)	4	87.5 MPa	UN 11/16"-16 for sealing with O-Lok [®] Face Seal* for tube Ø 10 (3/8")	UNF 9/16"-18 for sealing with O-Lok [®] Face Seal* for tube Ø 6 (1/4")

* Face Seal acc. to SAE J1453

ORDERING | WEH[®] TVR1 H₂ 70 MPa Check valve with female thread / male thread and filter (20 µm)

approx. dimensions (mm)

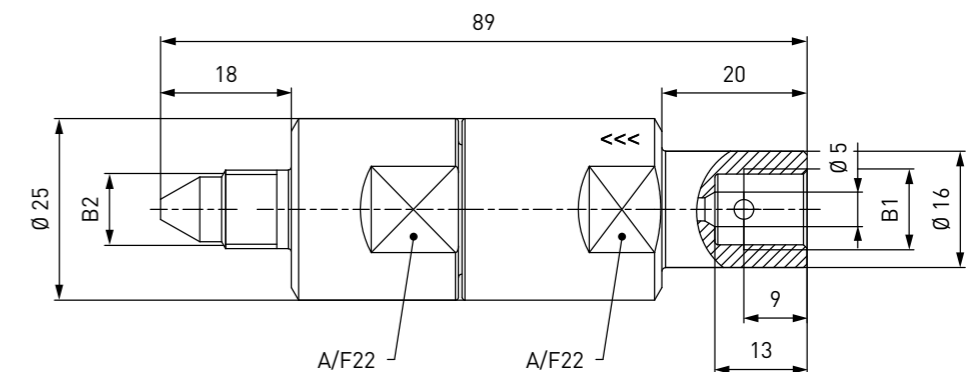

Part No.	Description	DN	Pressure (PS)	B1 (female thread)	B2 (male thread)
C1-87743	TVR1 H ₂ 70 MPa (EC79)	2.5	87.5 MPa	UNF 7/16"-20*	UNF 7/16"-20**

* MP-fitting, 60° inner cone

** MP-fitting, 59° outer cone

Other connection sizes and types (e.g. Cone and Thread Fittings or VOSSLok⁴⁰) on request.

» Check valve TVR1 H₂

DESCRIPTION



Features

- Robust construction
- Low-noise opening and closing
- Corrosion resistant stainless steel
- High leak tightness

With the TVR1 H₂ WEH offers a high-performance check valve for use with gaseous hydrogen.

The seals in the valve are arranged to prevent them from being damaged by dirt particles in the gas flow. The WEH[®] TVR1 H₂ Check valve is made of corrosion-resistant stainless steel achieving a very durable unit due to its robust internal structure.

Application

Check valve for cars, also suitable for installation in hydrogen fueling stations.

TECHNICAL DATA

Characteristics	Basic version
Nominal bore (DN)	8 mm
Pressure range	PN = 35 MPa PS = 45 MPa
Temperature range	-40 °C up to +85 °C
Material	Corrosion resistant stainless steel (inner components partially made of brass: C1-18485/4)
Sealing material	Hydrogen resistant
Design	Incl. fittings (only for check valves with tube fitting) With integrated particle filter on request
Conformity / Tests / Approvals	00 0005 (Regulation (EC) No. 79/2009)

Other designs on request

» Check valve TVR1 H₂

ORDERING | WEH[®] TVR1 H₂ Check valve with tube fitting on both sides

approx. dimensions (mm)

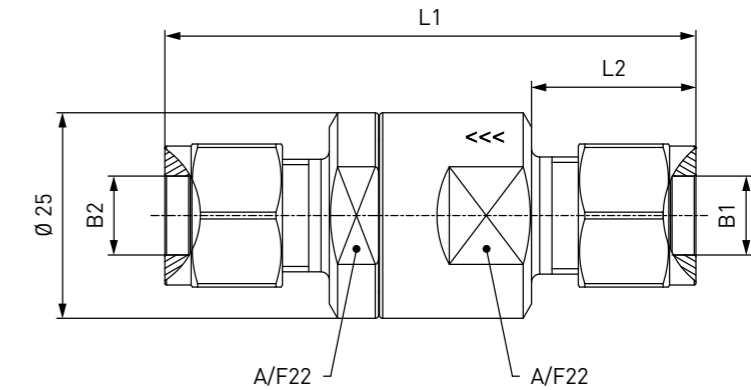

Part No.	Description	DN	Pressure (PS)	B1	B2	L1	L2
C1-18485/4	TVR1 H ₂ (EC79)	8	45 MPa	Tube Ø 3/8"	Tube Ø 3/8"	65.0	20.0
C1-43215	TVR1 H ₂ (EC79)	8	45 MPa	Tube Ø 10*	Tube Ø 10*	65.0	20.0

* double ferrule fitting

Other connection sizes and types (e.g. Cone and Thread Fittings or VOSSLok⁴⁰) on request.

» Fueling nozzle TK16 H₂ High-Flow

DESCRIPTION



Features

- Type A acc. to SAE J2600 resp. ISO 17268
- Compatible with WEH[®] TN1 H₂ High-Flow Receptacle profile
- WEH EASY-TURN[®] 360° swivel joint for actuation lever
- Easy operation
- Increased flow rate → even shorter filling times
- Recirculation of the vented gas
- Plastic thermal protection
- WEH[®] Jaw locking mechanism
- High-grade materials
- Coding for pressure range / gas type (acc. to table below)

The WEH[®] TK16 H₂ High-Flow Fueling nozzle enables an even faster filling of buses and trucks with hydrogen. Due to the increased flow rate, the already short filling times have been shortened even further.

The integrated swivel joint is located directly on the actuation lever, making it easy to rotate the fueling nozzle to the optimum connection position. The actuating lever can be switched with little effort when connecting and disconnecting.

The internal coding for pressure range and gas type ensures that the TK16 H₂ High-Flow can be connected to the compatible WEH[®] Receptacles acc. to the opposite table and also prevents the risk of confusion with natural gas.

The WEH[®] TK16 H₂ High-Flow offers optimum safety for the operator. The fueling nozzle remains connected to the receptacle until the gas between inlet valve and receptacle is depressurized.

Application

Fueling nozzle for hydrogen fast filling of buses and trucks at self-service fueling stations.

TECHNICAL DATA

Characteristics	Basic version
Nominal bore (DN)	8 mm
Pressure range	PN = 35 MPa PS = 45 MPa
Media temperature range	-20 °C up to +85 °C
Ambient temperature range	-40 °C up to +85 °C
Material	Corrosion resistant
Sealing material	Hydrogen resistant
Nozzle type	Type A acc. to SAE J2600:2015 and previous resp. ISO 17268:2012 and previous
Design	With plastic thermal protection and gas recirculation
Weight	Approx. 1.8 kg
Conformity / Tests / Approvals	Tests acc. to SAE J2600:2002

Other designs on request

TK16 H ₂ HF*	TN1 H ₂			
	25 MPa	35 MPa	35 MPa HF*	70 MPa
35 MPa HF*			✓	

* HF = High-Flow

» Fueling nozzle TK16 H₂ High-Flow

ORDERING | WEH[®] TK16 H₂ High-Flow Fueling nozzle

approx. dimensions (mm)

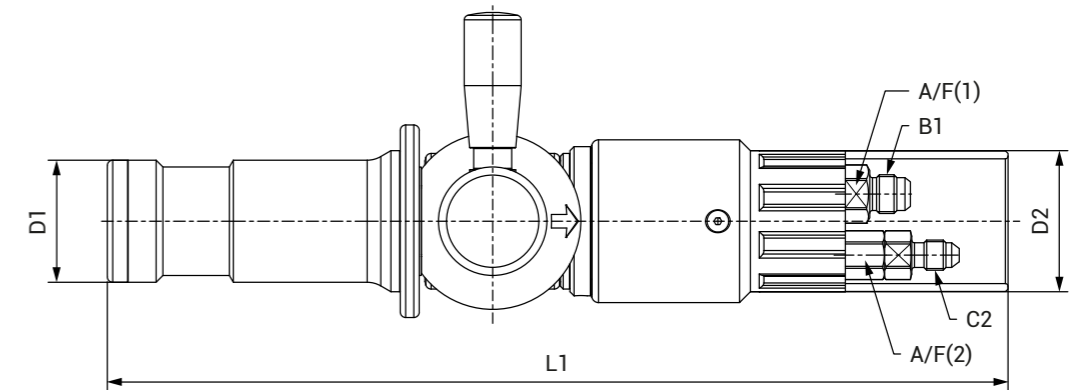

Part No.	Description	Pressure (PS)	B1 (male thread)	C2 (male thread)	L1	D1	D2	A/F(1)	A/F(2)
C1-85042-X01	TK16 H ₂ High-Flow	45 MPa	UNF 9/16"-18*	UNF 7/16"-20*	332	45	52	19	16

* acc. to SAE J514, 37° cone

Fueling assemblies consisting of fueling nozzle, hose set and breakaway coupling are available on request.

ACCESSORIES

The following accessories are available for the WEH[®] TK16 H₂ High-Flow Fueling nozzle:

Hose set

Hose set for connecting fueling nozzle and TSA1 H₂ breakaway coupling, complete with filling and venting hose, fittings and press-fittings supported by coil spring stubs. Not suitable for refueling with pre-cooled hydrogen acc. to SAE J2601.

Design filling/venting hose:

max. operating pressure PS: 45 MPa / nominal bore (DN): 4.5 mm / media temperature range: -20 °C up to +90 °C



Part No.	B1/B2 (female thread)	C1/C2 (female thread)	Hose length
C1-60917	UNF 9/16"-18*	UNF 7/16"-20*	3 m
C1-60920	UNF 9/16"-18*	UNF 7/16"-20*	4 m
C1-60923	UNF 9/16"-18*	UNF 7/16"-20*	5 m

* acc. to SAE JIC, 37° cone

» Fueling nozzle TK16 H₂ High-Flow

Dispenser mounting

Mounting for safe attachment of the fueling nozzle to the dispenser.

Switch actuated (with pin) resp. not switch actuated dispenser mounting
approx. dimensions (mm)

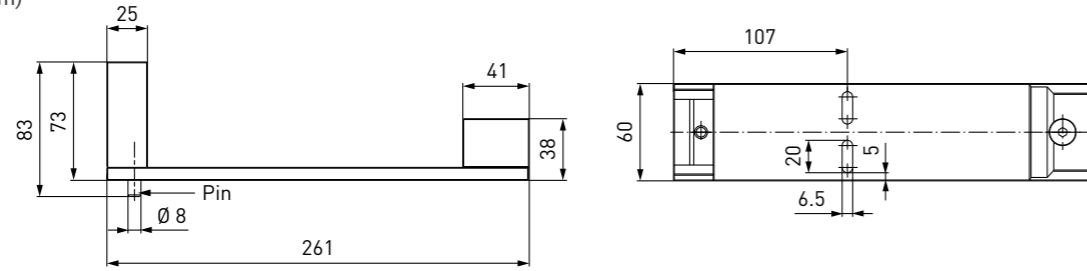

Switch actuated dispenser mounting with weather protection
approx. dimensions (mm)

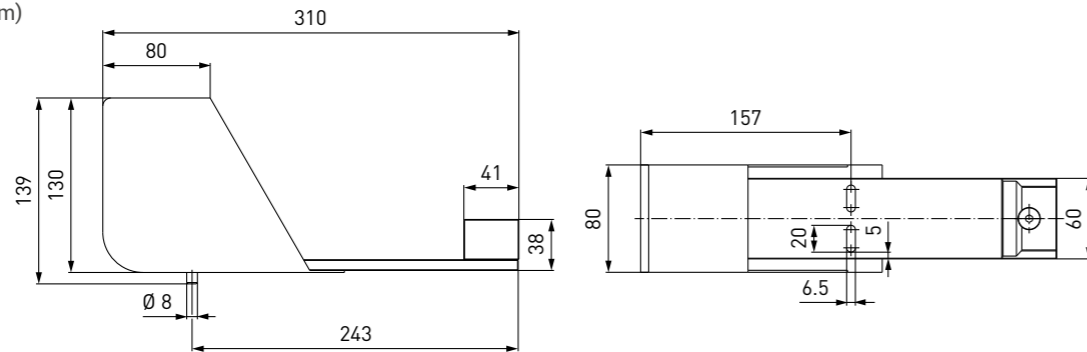

Part No.	Description
C1-86860	Dispenser mounting (switch actuated)
C1-109880	Dispenser mounting (not switch actuated)
C1-109678	Dispenser mounting (switch actuated) with weather protection

WEH® TNS1 H₂ Service receptacle

To prevent damage in the fueling nozzle while purging or leak testing during maintenance in the course of which pressure is applied, we recommend the use of a service receptacle. The receptacle also protects the fueling nozzle from dirt ingress whilst not in use.



Part no.	Description
C1-148079	TNS1 H ₂ Service receptacle incl. protection cap

WEH® Breakaway couplings

For the suitable TSA1 H₂ breakaway coupling or TSA2 H₂ inline breakaway coupling, please see page 41 - 42 resp. 47.

» Fueling nozzle TK16 H₂ High-Flow

SPARE PARTS

Various parts are available as spares for the WEH® TK16 H₂ High-Flow Fueling nozzle.



Part No.	Description
E80-172676	1 Impact protection
W72504	2 Actuation lever
E80-163068	3 Cover plate
W136178	4 Protection sleeve (incl. 3 countersunk screws)
E99-44923	Maintenance spray

» Fueling nozzle TK16 H₂ High-Flow with data interface

DESCRIPTION



Features

- Type A acc. to SAE J2600 resp. ISO 17268
- Compatible with WEH[®] TN1 H₂ High-Flow and with WEH[®] TN1 H₂ 70 MPa Receptacle profile
- Integrated infrared data interface
- WEH EASY-TURN[®] 240° swivel joint for actuation lever
- Easy operation
- Increased flow rate → even shorter filling times
- Recirculation of the vented gas
- Plastic thermal protection
- WEH[®] Jaw locking mechanism
- High-grade materials
- Coding for pressure range / gas type (acc. to table below)

The WEH[®] TK16 H₂ High-Flow fueling nozzle with data interface enables an even faster filling of buses and trucks with hydrogen. Due to the increased flow rate, the already short filling times have been shortened even further. The integrated swivel joint is located directly on the actuation lever, making it easy to rotate the fueling nozzle to the optimum connection position. The actuating lever can be switched with little effort when connecting and disconnecting.

The internal coding for pressure range and gas type ensures that the TK16 H₂ High-Flow with data interface can be connected to the compatible WEH[®] Receptacles acc. to the opposite table and also prevents the risk of confusion with natural gas. Furthermore, the fueling nozzle has an interface (infrared) for data transfer between the vehicle and the fueling station.

The WEH[®] TK16 H₂ High-Flow with data interface offers optimum safety for the operator. The fueling nozzle remains connected to the receptacle until the gas between inlet valve and receptacle is depressurized.

Application

Fueling nozzle for hydrogen fast filling of buses and trucks at self-service fueling stations.

TECHNICAL DATA

Characteristics	Basic version
Nominal bore (DN)	8 mm
Pressure range	PN = 35 MPa PS = 45 MPa
Media temperature range	-20 °C up to +85 °C
Ambient temperature range	-40 °C up to +85 °C
Material	Corrosion resistant
Sealing material	Hydrogen resistant
Nozzle type	Type A acc. to SAE J2600:2015 and previous resp. ISO 17268:2012 and previous
Design	With plastic thermal protection, gas recirculation and data interface acc. to SAE J2601
Weight	Approx. 2.4 kg
Conformity / Tests / Approvals	Fueling nozzle: tests acc. to SAE J2600:2002 IR data interface: ATEX; NEC on request

Other designs on request

» Fueling nozzle TK16 H₂ High-Flow with data interface

ORDERING | WEH[®] TK16 H₂ High-Flow Fueling nozzle with data interface

approx. dimensions (mm)

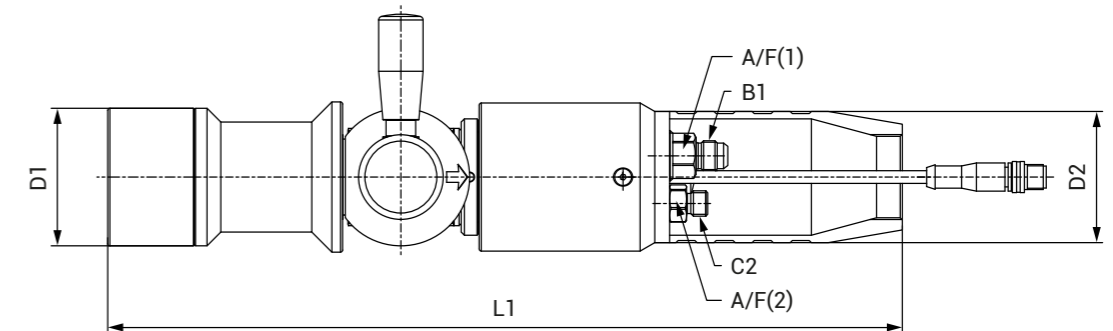

Part No.	Description	Pressure (PS)	B1 (male thread)	C2 (male thread)	L1	D1	D2	A/F(1)	A/F(2)
C1-94315-X01	TK16 H ₂ High-Flow (ATEX IR data interface)	45 MPa	UNF 9/16"-18*	M12x1.5	376	65	62	19	16

* acc. to SAE J514, 37° cone

On request the TK16 H₂ High-Flow fueling nozzle with data interface is also available with NEC approval. Fueling assemblies consisting of fueling nozzle, hose set and breakaway coupling are available on request.

ACCESSORIES

The following accessories are available for the WEH[®] TK16 H₂ High-Flow Fueling nozzle with data interface:

Hose set

Hose set for connecting fueling nozzle and TSA1 H₂ breakaway coupling, complete with filling and venting hose, hose fittings, plastic spiral hose and cable for data interface. Not suitable for refueling with pre-cooled hydrogen acc. to SAE J2601. Design filling/venting hose: max. operating pressure PS: 45 MPa / nominal bore (DN): 4.5 mm (filling hose) resp. 2 mm (venting hose) / media temperature range: -20 °C up to +90 °C

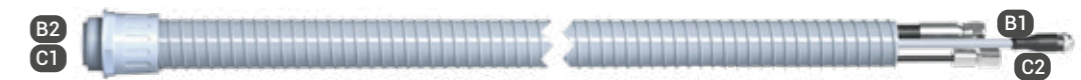

Part No.	B1/B2 (female thread)	C1/C2 (female thread)	Hose length
C1-90698	UNF 9/16"-18*	M12x1.5	3 m
C1-94428	UNF 9/16"-18*	M12x1.5	4 m
C1-94429	UNF 9/16"-18*	M12x1.5	5 m

* acc. to SAE JIC, 37° cone

» Fueling nozzle TK16 H₂ High-Flow with data interface

Dispenser mounting

Mounting for safe attachment of the fueling nozzle to the dispenser.

Not switch actuated dispenser mounting with protection of front sleeve

approx. dimensions (mm)

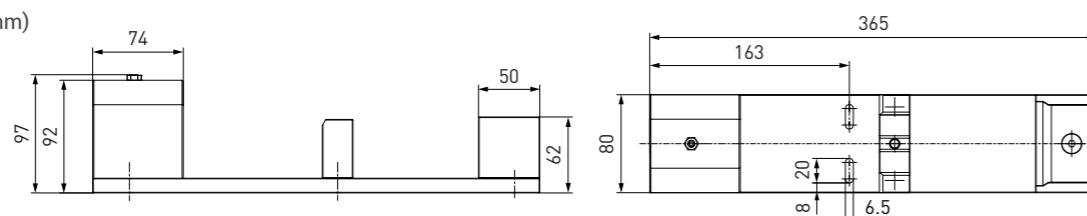

Switch actuated dispenser mounting with weather protection

approx. dimensions (mm)

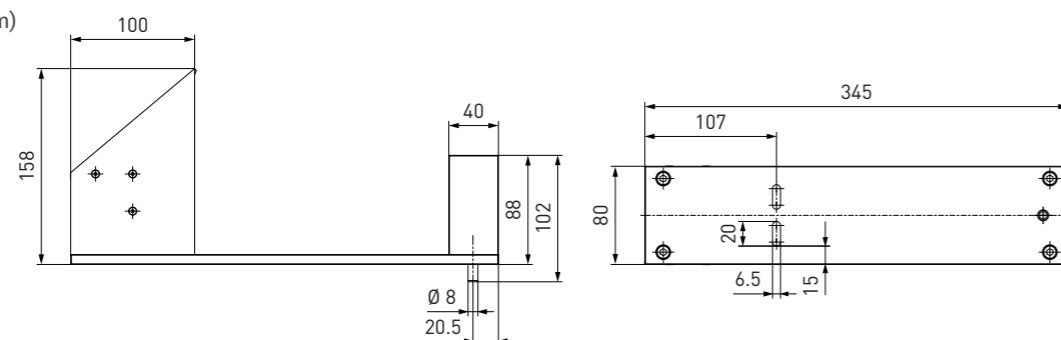

Switch actuated dispenser mounting with weather protection and angle plate 15°

approx. dimensions (mm)

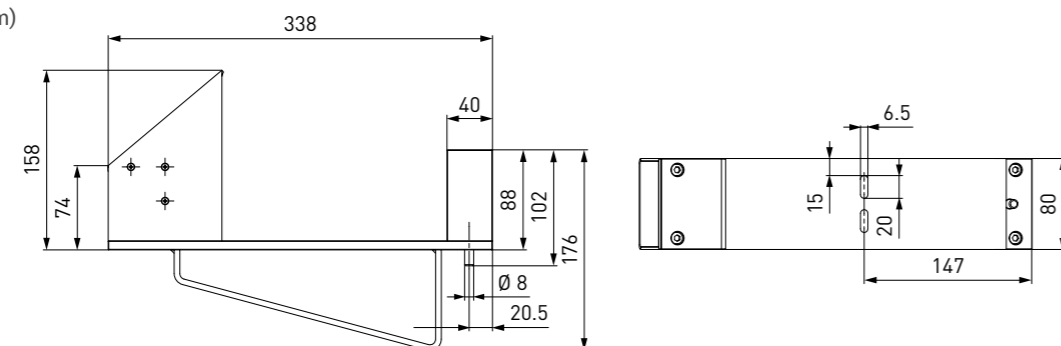

Part No.	Description
C1-94671	Dispenser mounting (not switch actuated) with protection of front sleeve
C1-175692	Dispenser mounting (switch actuated) with weather protection
C1-114632	Dispenser mounting (switch actuated) with weather protection and angle plate 15°

» Fueling nozzle TK16 H₂ High-Flow with data interface

WEH® TNS1 H₂ Service receptacle

To prevent damage in the fueling nozzle while purging or leak testing during maintenance in the course of which pressure is applied, we recommend the use of a service receptacle. The receptacle also protects the fueling nozzle from dirt ingress whilst not in use.



Part no.	Description
C1-148079	TNS1 H ₂ Service receptacle incl. protection cap

WEH® Breakaway coupling

For the suitable TSA1 H₂ breakaway coupling, please see page 43.

Data cable

Part no.	Description	Hose length
E68-96194	Data cable suitable for 4 m hose set	4.45 m
E68-96193	Data cable for connecting with the converter	3.45 m

Other lengths on request

SPARE PARTS

Various parts are available as spares for the WEH® TK16 H₂ High-Flow Fueling nozzle with data interface.



Part No.	Description
W72504	1 Actuation lever
E80-163068	2 Cover plate
W150340	3 Protection sleeve (incl. 3 countersunk screws)
E99-44923	Maintenance spray

» Fueling nozzle TK25 H₂

DESCRIPTION



Features

- Type A nozzle acc. to SAE J2600 resp. ISO 17268
- Compatible with WEH[®] TN5 H₂ receptacle profile
- Safe handling due to special safety function when disconnecting
- High flow rate → short filling times
- Recirculation of the vented gas
- Plastic thermal protection
- WEH[®] Jaw locking mechanism
- High-grade materials
- Coding for pressure range / gas type (acc. to table below)

The WEH[®] TK25 H₂ Fueling nozzle enables easy refueling of buses and trucks. Simply place the TK25 H₂ fueling nozzle onto the receptacle, turn the operating lever by 180° and the vehicle is refueled.

The internal coding for pressure range and gas type ensures that the WEH[®] TK25 H₂ can be connected to the compatible WEH[®] Receptacles acc. to the opposite table and also prevents the risk of confusion with natural gas.

The WEH[®] TK25 H₂ offers optimum safety for the operator. The fueling nozzle remains connected to the receptacle until the gas between inlet valve and receptacle is depressurized.

Application

Fueling nozzle for hydrogen fast filling of buses and trucks at self-service fueling stations.

TK25 H ₂	TN5 H ₂	
	25 MPa	35 MPa
35 MPa		✔

TECHNICAL DATA

Characteristics	Basic version
Nominal bore (DN)	12 mm
Pressure range	PN = 35 MPa PS = 45 MPa
Media temperature range	-20 °C up to +85 °C
Ambient temperature range	-40 °C up to +85 °C
Material	Corrosion resistant
Sealing material	Hydrogen resistant
Nozzle type	Type A acc. to SAE J2600:2015 and previous resp. ISO 17268:2012 and previous
Design	With plastic thermal protection and gas recirculation
Weight	Approx. 4.6 kg

Other designs on request

» Fueling nozzle TK25 H₂

ORDERING | WEH[®] TK25 H₂ Fueling nozzle

approx. dimensions (mm)

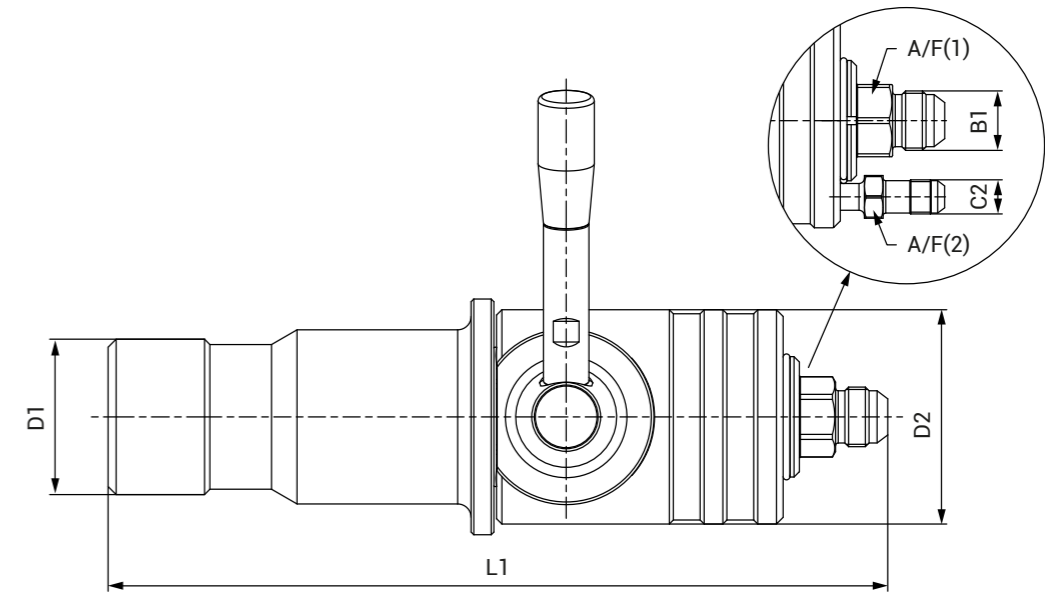

Part No.	Description	Pressure (PS)	B1 (male thread)	C2 (male thread)	L1	D1	D2	A/F(1)	A/F(2)
C1-62527-X1-X01	TK25 H ₂	45 MPa	UNF 7/8"-14*	UNF 9/16"-18*	297	58	80	27	16

* acc. to SAE J514, 37° cone

Fueling assemblies consisting of fueling nozzle, hose set and breakaway coupling are available on request.

ACCESSORIES

The following accessories are available for the WEH[®] TK25 H₂ Fueling nozzle:

Hose set

Hose set for connecting fueling nozzle and TSA5 H₂ breakaway coupling, complete with filling and venting hose, fittings and press-fittings supported by coil spring stubs. Not suitable for refueling with pre-cooled hydrogen acc. to SAE J2601. Design filling/venting hose: max. operating pressure PS: 45 MPa / nominal bore (DN): 5.6 mm (filling hose) resp. 4.5 mm (venting hose) / media temperature range: -20 °C up to +90 °C



Part No.	B1/B2 (female thread)	C1/C2 (female thread)	Hose length
C1-152556	UNF 7/8"-14*	UNF 9/16"-18*	3 m
C1-152557	UNF 7/8"-14*	UNF 9/16"-18*	4 m
C1-152558	UNF 7/8"-14*	UNF 9/16"-18*	5 m

* acc. to SAE JIC, 37° cone

» Fueling nozzle TK25 H₂

Dispenser mounting

Mounting for safe attachment of the fueling nozzle to the dispenser.

Switch actuated dispenser mounting

approx. dimensions (mm)

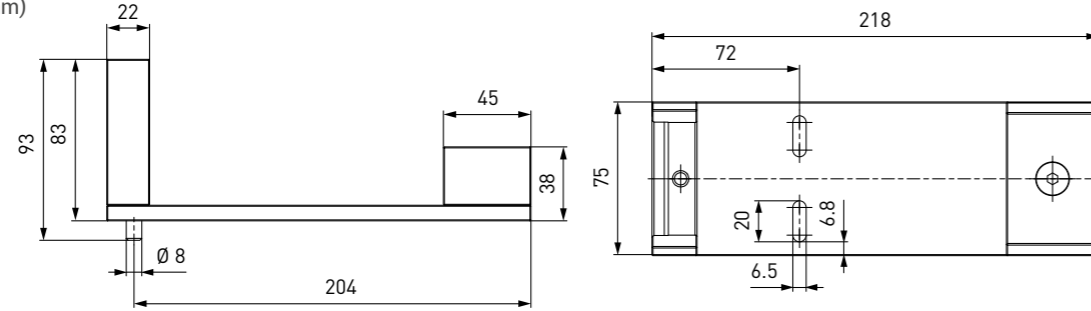

Switch actuated dispenser mounting with weather protection

approx. dimensions (mm)

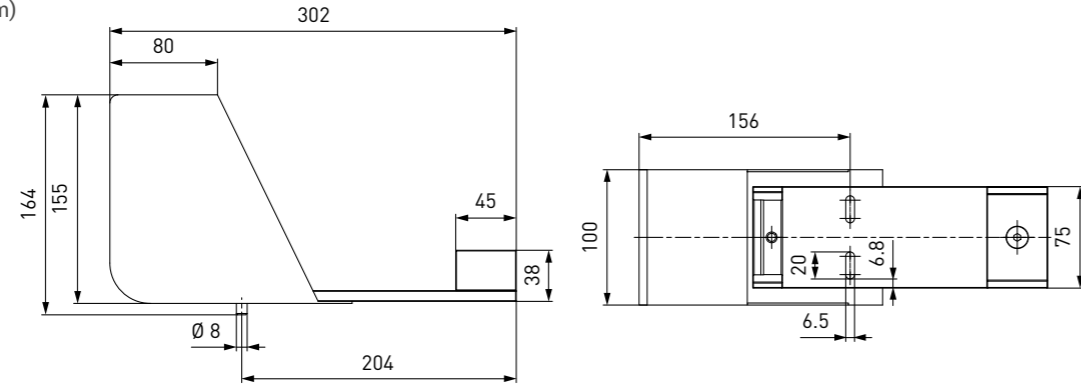

Part No.	Description
C1-83005	Dispenser mounting (switch actuated)
C1-82153	Dispenser mounting (switch actuated) and weather protection

WEH® TNS5 H₂ Service receptacle

To prevent damage in the fueling nozzle while purging or leak testing during maintenance in the course of which pressure is applied, we recommend the use of a service receptacle. The receptacle also protects the fueling nozzle from dirt ingress whilst not in use.



Part no.	Description
C1-157347	TNS5 H ₂ Service receptacle incl. protection cap

WEH® Breakaway couplings

For the suitable TSA5 H₂ breakaway coupling or TSA6 H₂ inline breakaway coupling, please see page 75 resp. 79.

» Fueling nozzle TK25 H₂

SPARE PARTS

Various parts are available as spares for the WEH® TK25 H₂ Fueling nozzle.



Part No.	Description
W6631	1 Actuation lever
E80-397S401	2 Cover plate
E99-44923	Maintenance spray

» Breakaway coupling TSA5 H₂

DESCRIPTION

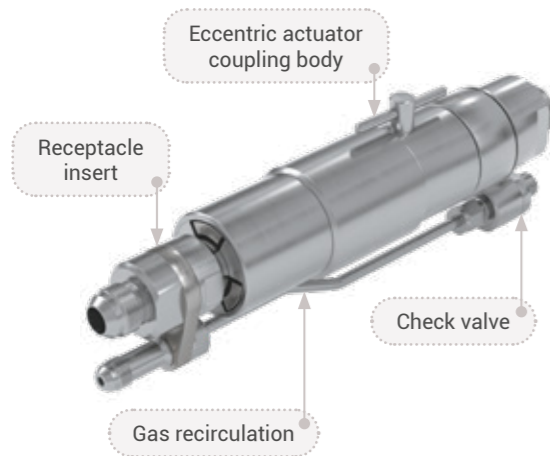

Features

- Reusable without factory servicing
- Installation at the dispenser
- Small compact design
- Integrated cleanable filter (40 µm)
- Check valve at venting line
- No additional tool necessary

The WEH[®] TSA5 H₂ Breakaway coupling provides additional safety for your bus and truck fueling station. The breakaway is installed between the dispenser and the filling/venting hose.

In the event of unexpected tensile forces, e.g. a vehicle driving away with a connected fueling nozzle, the breakaway separates the connections between dispenser and hoses in a controlled manner while sealing both ends. Damage to the vehicle's receptacle, the fueling nozzle and the dispenser can thus be prevented as far as possible. The breakaway coupling can be reused after a functional test.

The integrated filter cleans the hydrogen from dirt ingress and can be cleaned easily and quickly during maintenance.

The WEH[®] Breakaway coupling consists of a coupling body, a receptacle insert and a gas recirculation with check valve.

On request we also offer fueling assemblies consisting of fueling nozzle, hose set and breakaway coupling.

Application

Breakaway coupling for bus and truck hydrogen fueling stations for direct installation at the dispenser.

TECHNICAL DATA

Characteristics	Basic version
Nominal bore (DN)	12 mm
Pressure range	PN = 35 MPa PS = 45 MPa
Media temperature range	-20 °C up to +85 °C
Ambient temperature range	-40 °C up to +85 °C
Breakaway force	222 - 667 N
Material	Corrosion resistant stainless steel, aluminum
Sealing material	Hydrogen resistant
Design	With gas recirculation and filter (40 µm)

Other designs on request

» Breakaway coupling TSA5 H₂

ORDERING | WEH[®] TSA5 H₂ Breakaway coupling for TK25 H₂

approx. dimensions (mm)

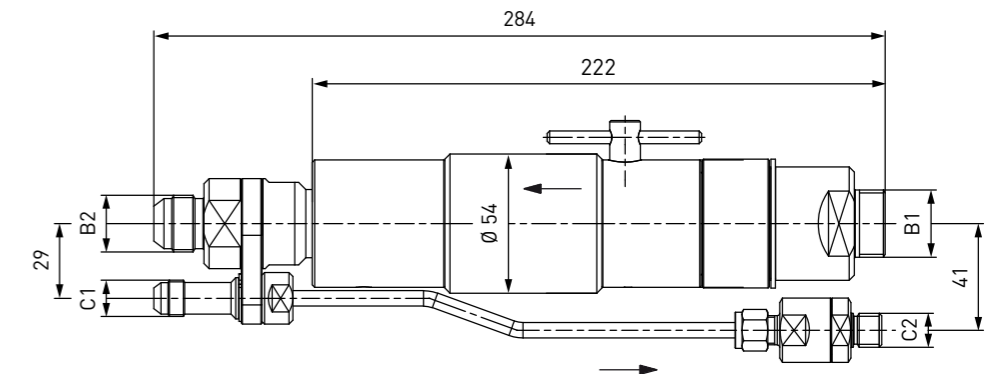

Part No.	Description	DN	Pressure (PS)	B1 (male thread)	B2 (male thread)	C1 (male thread)	C2 (male thread)
C1-17941-X7-X01	TSA5 H ₂ with filter (40 µm)	12	45 MPa	G3/4**	UNF 7/8"-14**	UNF 9/16"-18**	G1/4**

* acc. to DIN EN ISO 228-1

** acc. to SAE J514, 37° cone

» Breakaway coupling TSA5 H₂

ACCESSORIES

The following accessories are available for the WEH® TSA5 H₂ Breakaway coupling:

Dispenser mounting

The breakaway coupling can also be used with a dispenser mounting. The mounting is firmly attached to the dispenser. The integrated guide tube provides a straight pull-off force.

approx. dimensions (mm)

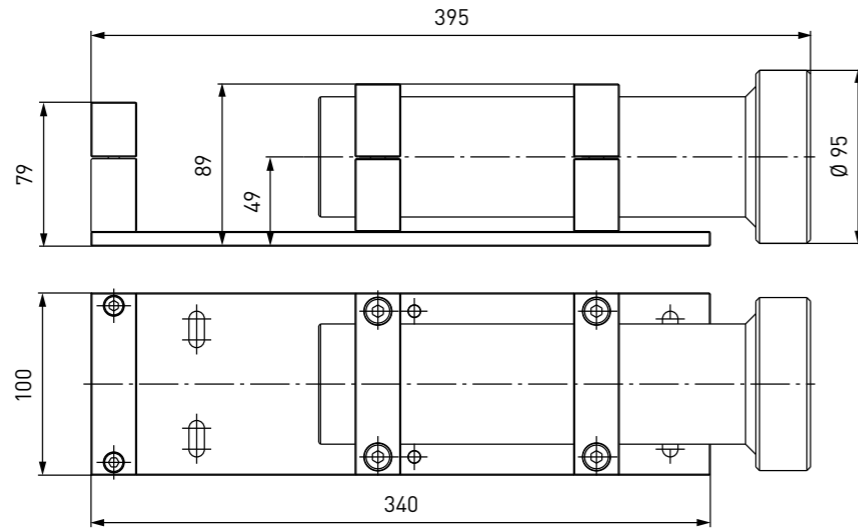

Part No.	Description
C1-82110	Dispenser mounting for TSA5 H ₂

Hoses

Suitable hoses for the TSA5 H₂ breakaway coupling are available on request.

» Breakaway coupling TSA5 H₂

SPARE PARTS

Various parts are available as spares for the WEH® TSA5 H₂ Breakaway coupling.

Part No.	Description
W83706	Receptacle insert for TSA5 H ₂
B200B-119726	Spare seals set for receptacle insert W83706
W139034	Spare parts set consisting of a gas recirculation tube (length: approx. 195 mm) and a firmly mounted check valve
W9062	Wire filter insert 40 µm

» Inline breakaway coupling TSA6 H₂

DESCRIPTION

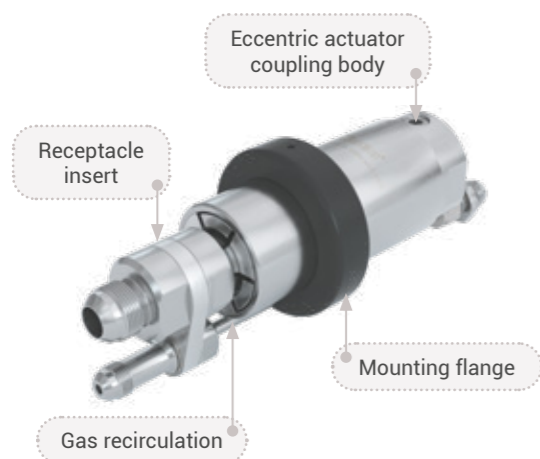

Features

- Reusable without factory servicing
- Installation between the filling and venting hoses
- Small compact design
- Mounting flange
- Eccentric actuation via Allen wrench

With the WEH[®] TSA6 H₂ Breakaway coupling, an inline breakaway coupling is also available for bus and truck refueling stations which is installed between the filling and venting hoses.

In the event of unexpected tensile forces, e.g. a vehicle driving away with a connected fueling nozzle, the breakaway separates the connections between dispenser and hoses in a controlled manner while sealing both ends. Damage to the vehicle's receptacle, the fueling nozzle and the dispenser can thus be prevented as far as possible. The breakaway coupling can be reused after a functional test.

The WEH[®] Breakaway coupling consists of a coupling body, a receptacle insert and a gas recirculation.

On request we also offer fueling assemblies consisting of fueling nozzle, hose set and inline breakaway coupling.

Application

Inline breakaway coupling for bus and truck hydrogen fueling stations for installation between the filling and venting hoses.

TECHNICAL DATA

Characteristics	Basic version
Nominal bore (DN)	12 mm
Pressure range	PN = 35 MPa PS = 45 MPa
Media temperature range	-20 °C up to +85 °C
Ambient temperature range	-40 °C up to +85 °C
Breakaway force	222 - 667 N
Material	Corrosion resistant stainless steel, aluminum
Sealing material	Hydrogen resistant
Design	With gas recirculation

Other designs on request

» Inline breakaway coupling TSA6 H₂

ORDERING | WEH[®] TSA6 H₂ Inline breakaway coupling for TK25 H₂

approx. dimensions (mm)

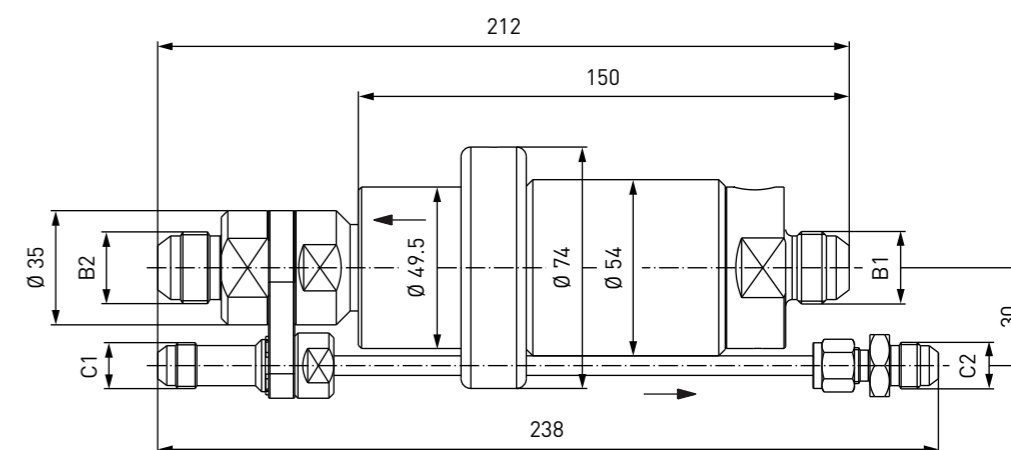

Part No.	Description	DN	Pressure (PS)	B1/B2 (male thread)	C1/C2 (male thread)
C1-82323-X01	TSA6 H ₂	12	45 MPa	UNF 7/8"-14*	UNF 9/16"-18*

* acc. to SAE J514, 37° cone

ACCESSORIES

The following accessories are available for the WEH[®] TSA6 H₂ Inline breakaway coupling:

Hoses

Suitable hoses for the TSA6 H₂ inline breakaway coupling are available on request.

SPARE PARTS

Various parts are available as spares for the WEH[®] TSA6 H₂ Inline breakaway coupling.

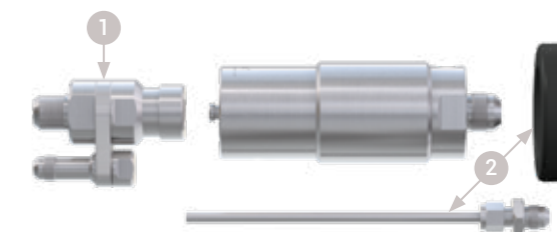

Part No.	Description
W83706	1 Receptacle insert for TSA6 H ₂
B200B-119726	Spare seals set for receptacle insert W83706
W139031	2 Spare parts set consisting of a mounting flange, a gas recirculation tube and a firmly mounted fitting

» Receptacle TN1 H₂ High-Flow

DESCRIPTION



Features

- Low-noise refueling
- Integrated self-cleaning particle filter (40 µm)
- Integrated high-flow check valve
- Sealing-friendly design
- Coding for pressure range / gas type (acc. to table below)

The WEH[®] TN1 H₂ High-Flow Receptacle was developed to fit the WEH[®] TK16 H₂ High-Flow Fueling nozzle. This enables buses and trucks to be refueled from now on at car fueling stations.

Refueling is done either with a TK16 H₂ or with a TK16 H₂ High-Flow fueling nozzle with increased flow rate. Due to the aerodynamic design of the internal shapes of the receptacle, noise during refueling process is mostly eliminated, while at the same time maximum flow rate is enabled. The internal seals are arranged to largely prevent damage to the sealing components. That is why the WEH[®] TN1 H₂ High-Flow proves to be extremely robust and durable, minimizing downtimes due to low maintenance.

The receptacle is equipped with an integrated check valve and has a coding for pressure range / gas type.

Enhanced safety by integrated particle filter

The use of an integrated particle filter prevents the ingress of dirt particles from the outside and therefore leakage at the receptacle is almost eliminated.

Application

Receptacle for hydrogen refueling / filling of buses, trucks and fork-lift trucks or other industrial applications, to be used with WEH[®] Fueling nozzles acc. to opposite table.

TK17 H ₂ / TK16 H ₂	TK17 H ₂ / TK16 H ₂			
	25 MPa	35 MPa	35 MPa HF*	70 MPa
TN1 H ₂ HF*	✓	✓	✓	

* HF = High-Flow

TECHNICAL DATA

Characteristics	Basic version
Nominal bore (DN)	Depending on design
Pressure range	PN = 35 MPa PS = 45 MPa
Temperature range	-40 °C up to +85 °C
Material	Corrosion resistant
Sealing material	Hydrogen resistant
Design	With protection cap, integrated particle filter (40 µm), integrated check valve and fittings (only for receptacles with tube fitting)
Conformity / Tests / Approvals	e 1 00 0003 (Regulation (EC) No. 79/2009)

Other designs on request

» Receptacle TN1 H₂ High-Flow

ORDERING | WEH[®] TN1 H₂ High-Flow Receptacle with tube fitting

approx. dimensions (mm)

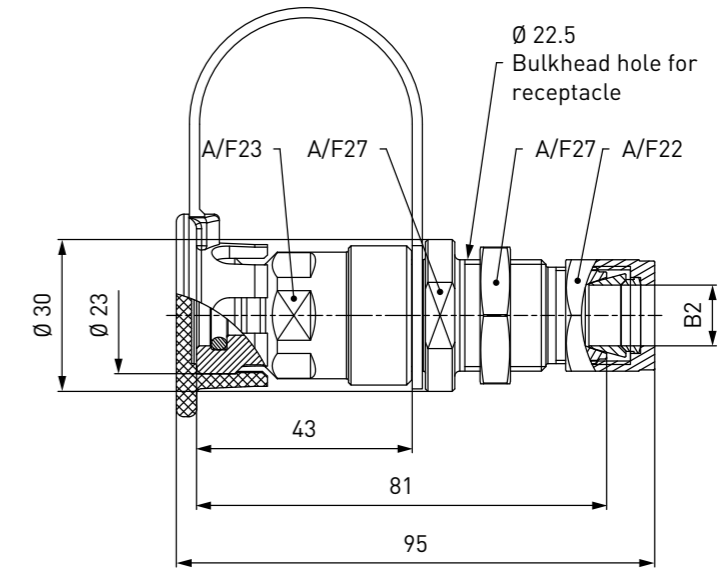

Part No.	Description	DN	Pressure (PS)	B2
C1-85040	TN1 H ₂ High-Flow (EC79)	8	45 MPa	Tube Ø 12*

* double ferrule fitting

» Receptacle TN1 H₂ High-Flow

ORDERING | WEH® TN1 H₂ High-Flow Receptacle with male thread, prepared for data interface

approx. dimensions (mm)

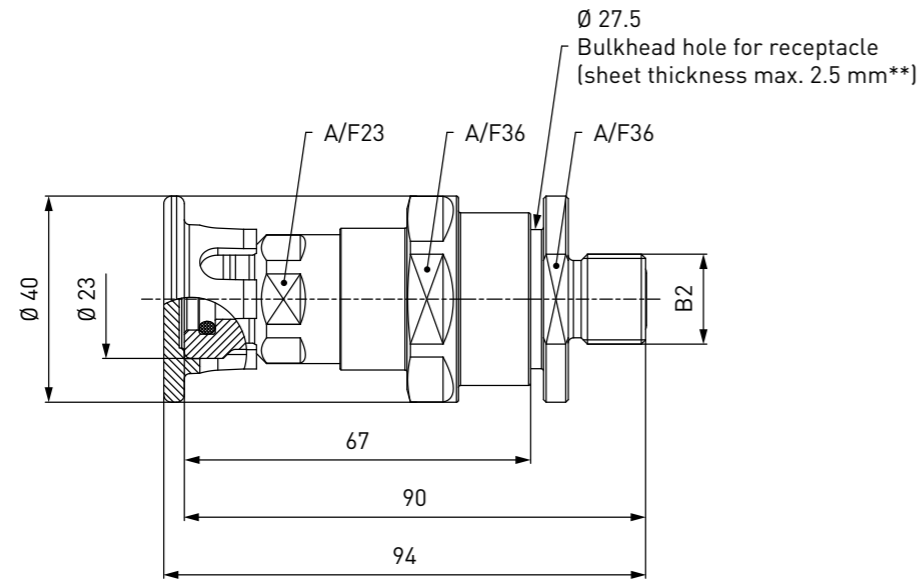

Part No.	Description	DN	Pressure (PS)	B2 (male thread)
C1-94306	TN1 H ₂ High-Flow (EC79)	6	45 MPa	UN 11/16"-16 for sealing with O-Lok® Face Seal* for tube Ø 10 (3/8")
C1-112679	TN1 H ₂ High-Flow (EC79)	8	45 MPa	UN 13/16"-16 for sealing with O-Lok® Face Seal* for tube Ø 12.7 (1/2")

* Face Seal acc. to SAE J1453

** Please indicate when ordering if thicker sheet metals are needed!
Data interface not included!

» Receptacle TN1 H₂ High-Flow

ORDERING | WEH® TN1 H₂ High-Flow Receptacle with tube fitting, prepared for data interface

approx. dimensions (mm)

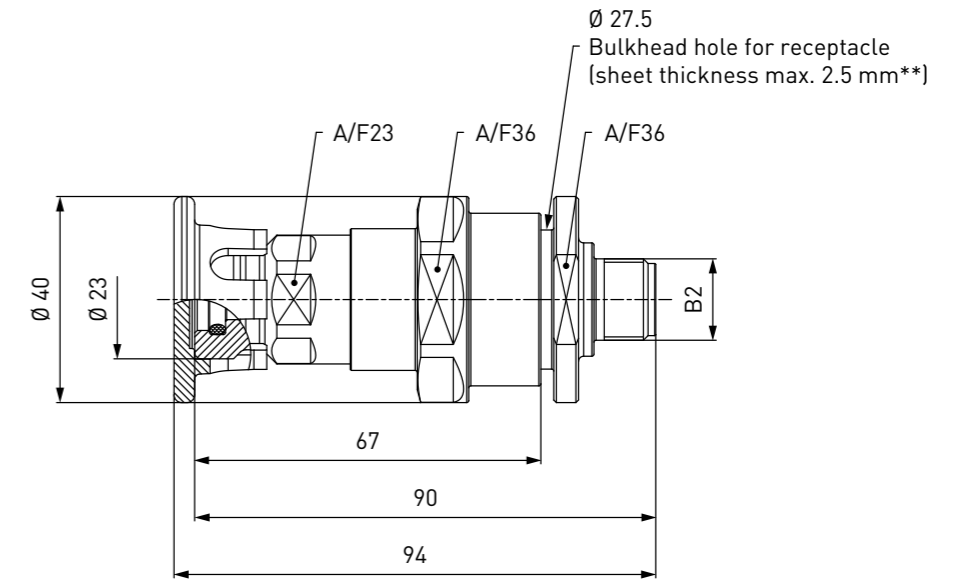

Part No.	Description	DN	Pressure (PS)	B2
C1-105920	TN1 H ₂ High-Flow (EC79)	6	45 MPa	Tube Ø 10*

* double ferrule fitting

** Please indicate when ordering if thicker sheet metals are needed!
Data interface and fittings not included!

Other connection sizes and types (e.g. Cone and Thread Fittings or VOSSLok⁴⁰) on request.

SPARE PARTS

Various parts are available as spares for the WEH® TN1 H₂ High-Flow Receptacle.

Protection cap

Protection cap with a strap to protect the receptacle from dirt ingress.

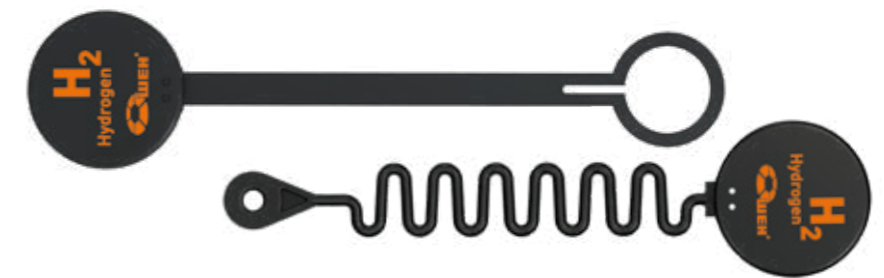

Part No.	Description
W87803	Protection cap
W85984	Protection cap for receptacles prepared for data interface

» Receptacle TN5 H₂

DESCRIPTION



Features

- Low-noise refueling
- Integrated self-cleaning particle filter (50 µm)
- Integrated high-flow check valve
- Sealing-friendly design
- Coding for pressure range / gas type (acc. to table below)

The WEH[®] TN5 H₂ Receptacle was specially designed for refueling buses and trucks with hydrogen. Due to the aerodynamic design of the internal shapes of the receptacle, noise during refueling process is mostly eliminated, while at the same time high flow rate is enabled. The internal seals are arranged to largely prevent damage to the sealing components. That is why the WEH[®] TN5 H₂ proves to be extremely robust and durable, minimizing downtimes due to low maintenance.

The receptacle is equipped with an integrated check valve and has a coding for pressure range / gas type.

Enhanced safety by integrated particle filter

The use of an integrated particle filter prevents the ingress of dirt particles from the outside and therefore leakage at the receptacle is almost eliminated.

Application

Receptacle for hydrogen refueling / filling of buses, trucks and fork-lift trucks or other industrial applications, to be used with WEH[®] TK25 H₂ Fueling nozzle.

		TK25 H ₂	
		25 MPa	35 MPa
TN5 H ₂	35 MPa	✓	✓

TECHNICAL DATA

Characteristics	Basic version
Nominal bore (DN)	Depending on design
Pressure range	PN = 35 MPa PS = 45 MPa
Temperature range	-40 °C up to +85 °C
Material	Corrosion resistant
Sealing material	Hydrogen resistant
Design	With protection cap, integrated particle filter (50 µm), integrated check valve and fittings
Conformity / Tests / Approvals	GB/T 26779-2021

Other designs on request

» Receptacle TN5 H₂

ORDERING | WEH[®] TN5 H₂ Receptacle with tube fitting

approx. dimensions (mm)

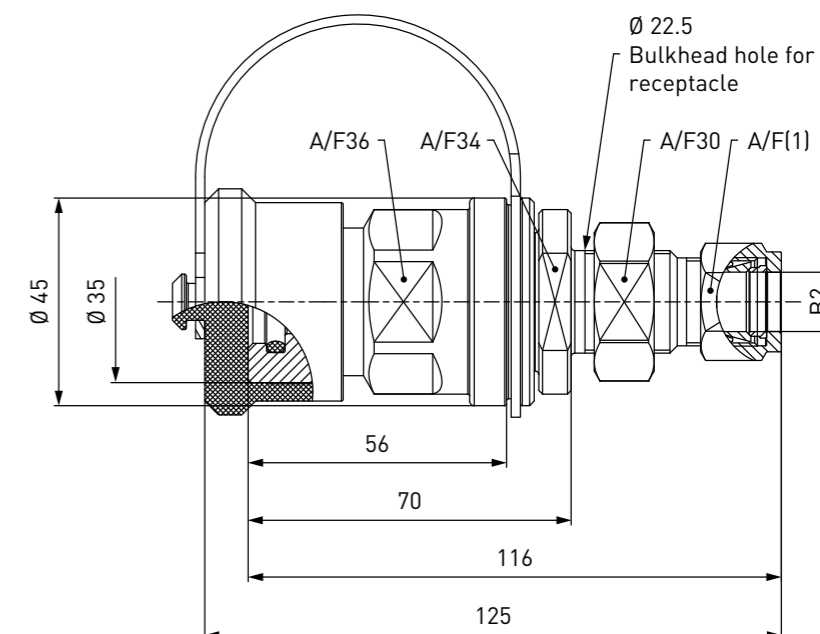

Part No.	Description	DN	Pressure (PS)	B2	A/F(1)
C1-49772-X1-X01	TN5 H ₂	8	45 MPa	Tube Ø 12*	22
C1-174547	TN5 H ₂	10	45 MPa	Tube Ø 1/2**	22
C1-19136-X1-X01	TN5 H ₂	12	45 MPa	Tube Ø 16*	25

* double ferrule fitting

Other connection sizes and types (e.g. Cone and Thread Fittings or VOSSLok⁴⁰) on request.

SPARE PARTS

Various parts are available as spares for the WEH[®] TN5 H₂ Receptacle.

Protection cap

Protection cap with a strap to protect the receptacle from dirt ingress.



Part No.	Description
E80-134306	Protection cap

» Check valve TVR5 H₂

DESCRIPTION



Features

- Robust construction
- Low-noise opening and closing
- Corrosion resistant stainless steel
- High leak tightness

The WEH[®] TVR5 H₂, the largest of our check valves, is extremely high performing and was developed specially for hydrogen buses and trucks.

The seals in the valve are arranged to prevent them from being damaged by dirt particles in the gas flow. The WEH[®] TVR5 H₂ Check valve is made of corrosion-resistant stainless steel achieving a very durable unit due to its robust internal structure.

Application

Check valve for buses and trucks, also suitable for installation in hydrogen fueling stations.

TECHNICAL DATA

Characteristics	Basic version
Nominal bore (DN)	Depending on design
Pressure range	PN = 35 MPa PS = 45 MPa
Temperature range	-40 °C up to +85 °C
Material	Corrosion resistant stainless steel
Sealing material	Hydrogen resistant
Design	Incl. fittings (only for check valves with tube fitting)
Conformity / Tests / Approvals	On request

Other designs on request

» Check valve TVR5 H₂

ORDERING | WEH[®] TVR5 H₂ Check valve with tube fitting on both sides

approx. dimensions (mm)

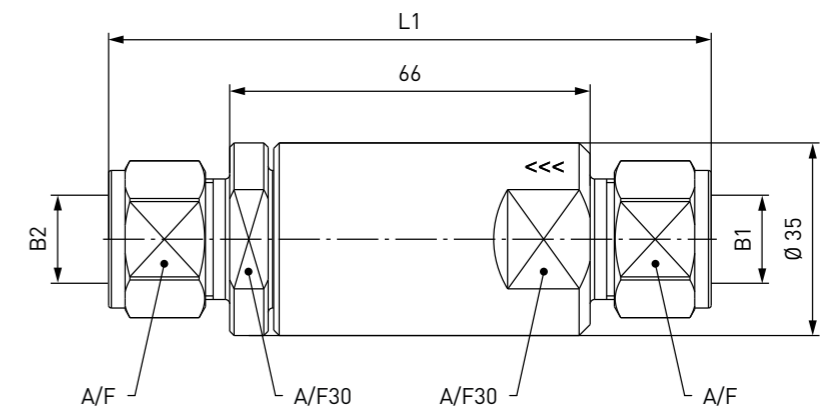

Part No.	Description	DN	Pressure (PS)	B1	B2	L1	A/F
C1-30216-X1-X01	TVR5 H ₂	11	45 MPa	Tube Ø 12*	Tube Ø 12*	110	22
C1-30215-X1-X01	TVR5 H ₂	14	45 MPa	Tube Ø 16*	Tube Ø 16*	111	25

* double ferrule fitting

ORDERING | WEH[®] TVR5 H₂ Check valve with female thread on both sides

approx. dimensions (mm)

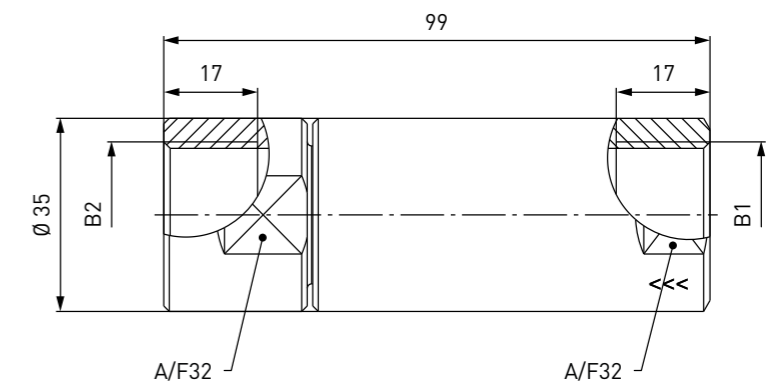

Part No.	Description	DN	Pressure (PS)	B1 (female thread)	B2 (female thread)
C1-43326-X1-X01	TVR5 H ₂	12	45 MPa	G3/4**	G3/4**

* acc. to DIN 3852-2

Other connection sizes and types (e.g. Cone and Thread Fittings or VOSSLok⁴⁰) on request.

» Filter TSF2 H₂

DESCRIPTION



Features

- For clean filtered hydrogen
- Filter insert can be cleaned
- For installation onboard H₂ vehicles and in H₂ fueling stations
- Also suitable as prefilter for inline breakaway couplings

When refueling hydrogen, it can often happen that hydrogen with dirt particles is fueled. These contaminated particles in the gas may cause damage to the sealing components. WEH therefore offers the WEH[®] TSF2 H₂ Filter for clean filtered hydrogen. Solid particles are reliably captured. The filter element can be removed and can be reused after cleaning.

The WEH[®] TSF2 H₂ Filter is mainly used in fueling stations and plants. To meet the different requirements of dispenser manufacturers, a wide variety of connection configurations are available - tube fitting / female thread on both ends or female and male thread.

For use as a prefilter with WEH[®] TSA2 H₂ Inline breakaway coupling, WEH offers a special design with male and female thread.

Application

Filter for installation in hydrogen vehicles and fueling stations.

TECHNICAL DATA

Characteristics	Basic version
Nominal bore (DN)	Depending on design
Pressure range	PN = 35 MPa PS = 45 MPa
Temperature range	-40 °C up to +85 °C
Material	Corrosion resistant stainless steel
Sealing material	Hydrogen resistant
Filter element	40 µm or 20 µm
Design	Incl. fittings (only for filters with tube fitting)
Conformity / Tests / Approvals	On request

Other designs on request

» Filter TSF2 H₂

ORDERING | WEH[®] TSF2 H₂ Filter with tube fitting on both sides

approx. dimensions (mm)

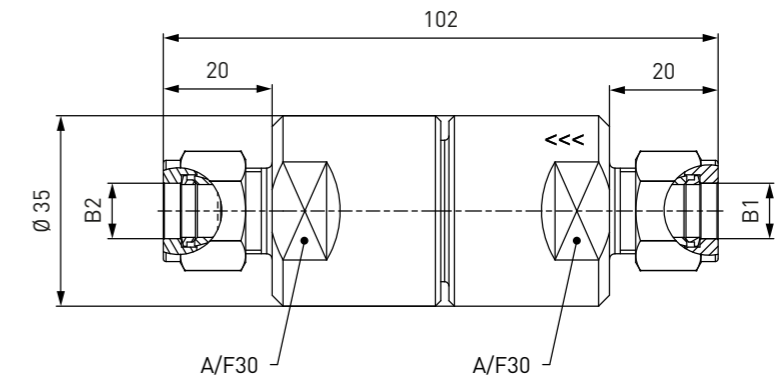

Part No.	Description	Filter (µm)	DN	Pressure (PS)	B1	B2
C1-18487-X01	TSF2 H ₂	40	8	45 MPa	Rohr Ø 3/8"	Rohr Ø 3/8"
C1-36033-X01	TSF2 H ₂	40	8	45 MPa	Rohr Ø 10*	Rohr Ø 10*

* double ferrule fitting

ORDERING | WEH[®] TSF2 H₂ Filter with female thread on both sides

ca.-Maße (mm)

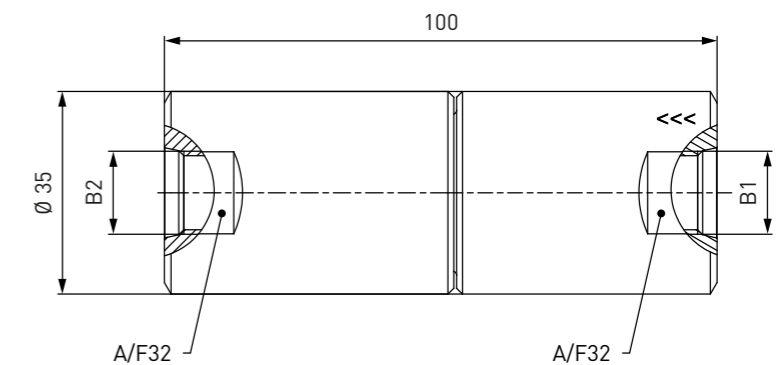

Part No.	Description	Filter (µm)	DN	Pressure (PS)	B1 (female thread)	B2 (female thread)
C1-34576-X01	TSF2 H ₂	40	8	45 MPa	UNF 9/16"-18*	UNF 9/16"-18*

* acc. to SAE J1926-1

» Filter TSF2 H₂

ORDERING | WEH® TSF2 H₂ Filter with male and female thread (also suitable as prefilter for TSA2 H₂)

approx. dimensions (mm)

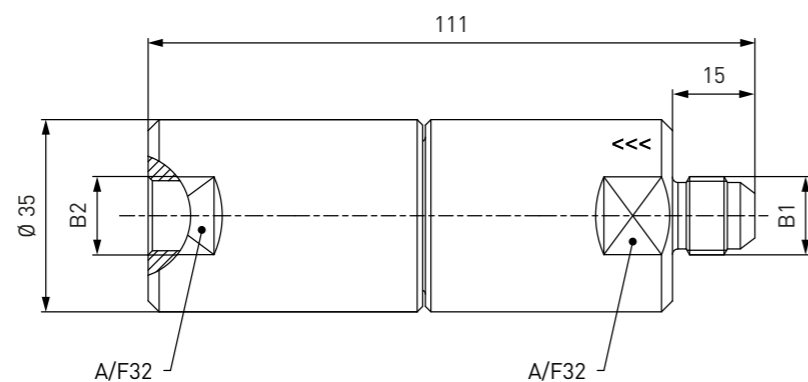

Part No.	Description	Filter (µm)	DN	Pressure (PS)	B1 (male thread)	B2 (female thread)
C1-134710-X01	TSF2 H ₂	40	8	45 MPa	UNF 9/16"-18*	UNF 9/16"-18*
C1-134711-X01	TSF2 H ₂	20	8	45 MPa	UNF 9/16"-18*	UNF 9/16"-18*

* acc. to SAE J514, 37° cone

Other connection sizes and types (e.g. Cone and Thread Fittings or VOSSLok⁴⁰) on request.

» Filter TSF2 H₂

SPARE PARTS

Various parts are available as spares for the WEH® TSF2 H₂ Filter.

Part No.	Description
E69-9061	Wire filter insert 40 µm (incl. spring and o-ring)
W67754	Wire filter insert 20 µm (incl. spring and o-ring)

» Coalescing filter TSF2 H₂

DESCRIPTION



Features

- Fine filter with high particle retention capacity (efficiency of approx. 99.9 % > 0.3 μm)
- For installation in H₂ vehicles and fueling stations
- Protection of critical components in the fuel system
- Wear resistant and corrosion resistant
- Ease of maintenance

When refueling with hydrogen, clean, filtered gases are a basic requirement for the proper functioning of the vehicle and fueling station components. The WEH[®] TSF2 H₂ Coalescing filter was developed to remove contaminants from the gas flow.

Coalescing filters are even more effective than normal particle filters due to their high particle retention capacity. The TSF2 H₂ filters the gas flow and reliably and safely removes the contaminated components contained in the gas, such as oil, water aerosols and dirt particles. These contaminated particles are separated by the coalescing filter. Hydrogen flows through the filter, whereas the slower flowing components such as oil, water and other liquid aerosols coalesce, drop to the bottom of the filter where they can be separated out via the drain port.

The WEH[®] TSF2 H₂ is easy to maintain and can also be installed in vehicles and fueling stations later on.

Application

Coalescing filter for installation in hydrogen vehicles and fueling stations.

TECHNICAL DATA

Characteristics	Basic version
Nominal bore (DN)	10 mm
Pressure range	PN = 35 MPa PS = 45 MPa
Temperature range	-40 °C up to +85 °C
Material	Corrosion resistant stainless steel
Sealing material	Hydrogen resistant
Filter element	< 1 μm
Design	Incl. plug
Conformity / Tests / Approvals	 00 0004 (Regulation (EC) No. 79/2009)

Other designs on request

» Coalescing filter TSF2 H₂

ORDERING | WEH[®] TSF2 H₂ Coalescing filter with filter cartridge Ø 38 mm

approx. dimensions (mm)

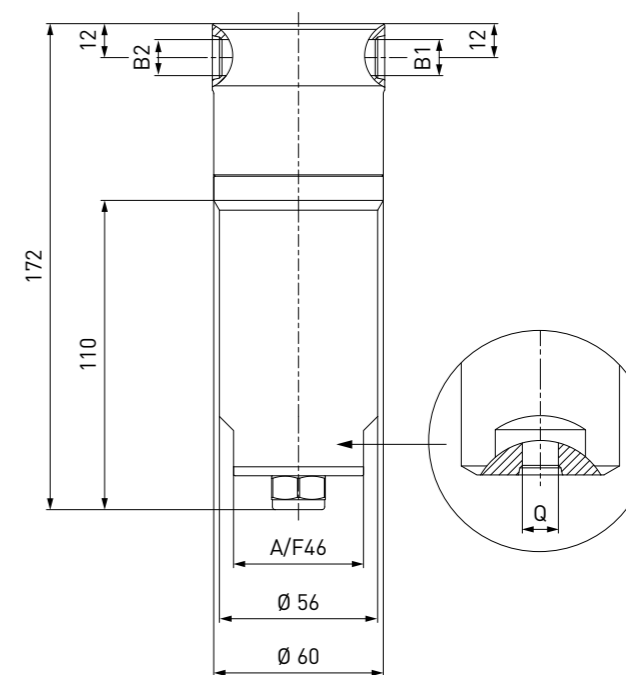

Part No.	Description	Pressure (PS)	B1 (female thread)	B2 (female thread)	Q (female thread)
C1-89635	TSF2 H ₂ (EC79)	45 MPa	UNF 9/16"-18*	UNF 9/16"-18*	UNF 9/16"-18*
C1-120710-X01	TSF2 H ₂	45 MPa	UNF 9/16"-18*	UNF 9/16"-18*	UNF 9/16"-18*

* acc. to SAE J1926-1

Other connection sizes and types (e.g. Cone and Thread Fittings or VOSSLok⁴⁰) on request.

SPARE PARTS

Various parts are available as spares for the WEH[®] TSF2 H₂ Coalescing filter.

Plug

Plug with suitable o-ring (of polyurethane) for closing the drain port 'Q' (end of the filter).



Part No.	Description	Port (male thread)
E69-93336	Plug with o-ring	UNF 9/16"-18*

* acc. to SAE J1926-1

Spare parts set

Suitable for TSF2 H₂ coalescing filter.

Part No.	Description
B200B-168192	Spare parts set consisting of filter cartridge Ø 38 mm, back-up ring and 2 o-rings

» Filter TSF4 H₂

DESCRIPTION



Features

- For clean filtered hydrogen
- Filter insert can be cleaned
- For installation onboard H₂ vehicles and in H₂ fueling stations

When refueling hydrogen, it can often happen that hydrogen with dirt particles is fueled. These contaminated particles in the gas may cause damage to the sealing components. WEH therefore offers the WEH[®] TSF4 H₂ Filter for clean filtered hydrogen. Solid particles are reliably captured.

The filter element can be removed and can be reused after cleaning.

The particle filter is specially designed for installation in vehicles, but can also be installed in fueling stations and plants, depending on the application.

Application

Filter for installation in hydrogen vehicles and fueling stations.

TECHNICAL DATA

Characteristics	Basic version
Nominal bore (DN)	10 mm
Pressure range	PN = 35 MPa PS = 45 MPa
Temperature range	-40 °C up to +85 °C
Material	Corrosion resistant stainless steel
Sealing material	Hydrogen resistant
Filter element	10 µm
Design	Incl. fittings (only for filters with tube fitting)
Conformity / Tests / Approvals	On request

Other designs on request

» Filter TSF4 H₂

ORDERING | WEH[®] TSF4 H₂ T-Filter with tube fitting on both sides

approx. dimensions (mm)

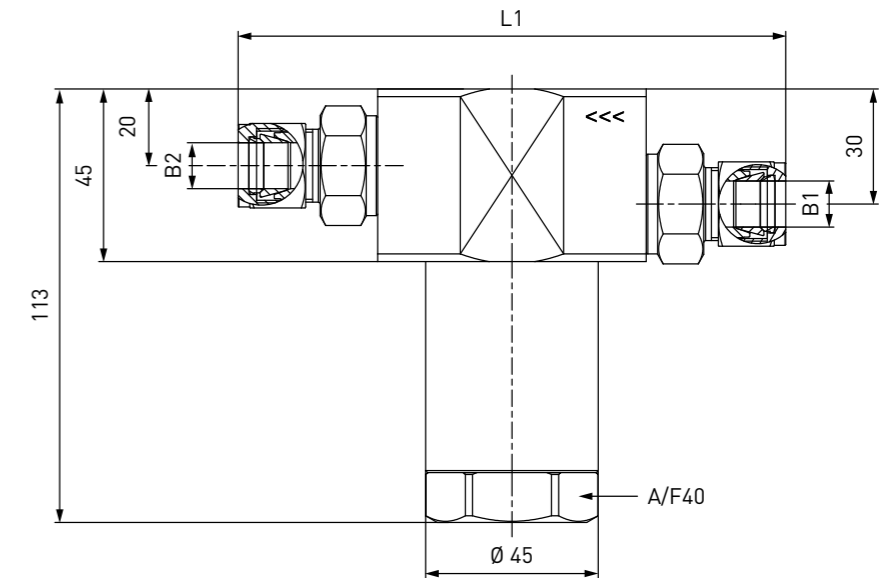

Part No.	Description	Filter (µm)	DN	Pressure (PS)	B1	B2	L1
C1-58026-X01	TSF4 H ₂	10	10	45 MPa	Tube Ø 12*	Tube Ø 12*	145
C1-73987-X01	TSF4 H ₂	10	10	35 MPa	Tube Ø 1/2**	Tube Ø 1/2**	145

* double ferrule fitting

Other connection sizes and types (e.g. Cone and Thread Fittings or VOSSLok⁴⁰) on request.

SPARE PARTS

Various parts are available as spares for the WEH[®] TSF4 H₂ Filter.

Part No.	Description
W9063	Wire filter insert 10 µm
E51-47589	O-ring for filter insert (only T-filter)

» Defueling nozzle TK6 H₂

DESCRIPTION

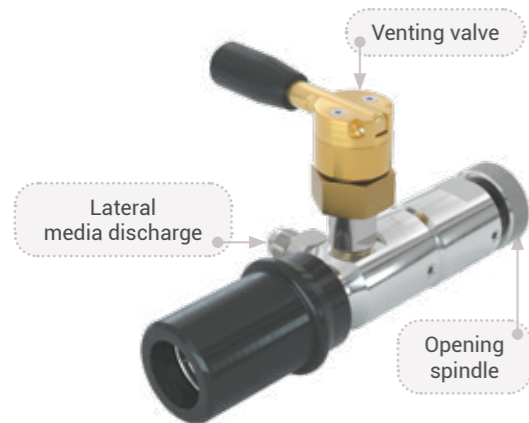

Features

- Discharge via filling port
- Actuation with opening spindle
- With venting valve (optionally also without venting valve)
- No additional shut-off device required
- Plastic thermal protection
- Only suitable for WEH[®] TN1 H₂ Receptacles without filter

The WEH[®] TK6 H₂ Defueling nozzle is used for maintenance and inspection of hydrogen vehicles. For maintenance, all pressure or fuel tanks must be discharged. WEH has designed the TK6 H₂ for easy connection and discharging of the hydrogen tanks.

The defueling nozzle is simply placed onto the receptacle in the car and the knurled spindle is screwed in until it stops. Then, the WEH[®] TN1 H₂ Receptacle is opened and the fuel tanks can be discharged via the lateral media discharge.

Application

Defueling nozzle for discharging hydrogen fuel tanks of cars via filling receptacle, only to be used with WEH[®] TN1 H₂ Receptacles without filter. Operation only by specially trained personnel. Not for self-service operation!

Attention: The TK6 H₂ may not be used for filling!

TECHNICAL DATA

Characteristics	Basic version
Nominal bore (DN)	6 mm
Pressure range	PN = 35 MPa PS = 45 MPa
Media temperature range	-20 °C up to +85 °C
Ambient temperature range	-40 °C up to +85 °C
Material	Corrosion resistant
Sealing material	Hydrogen resistant
Design	With plastic thermal protection, opening spindle and venting valve
Weight	Approx. 1.2 kg

Other designs on request

» Defueling nozzle TK6 H₂

ORDERING | WEH[®] TK6 H₂ Defueling nozzle with venting valve

approx. dimensions (mm)

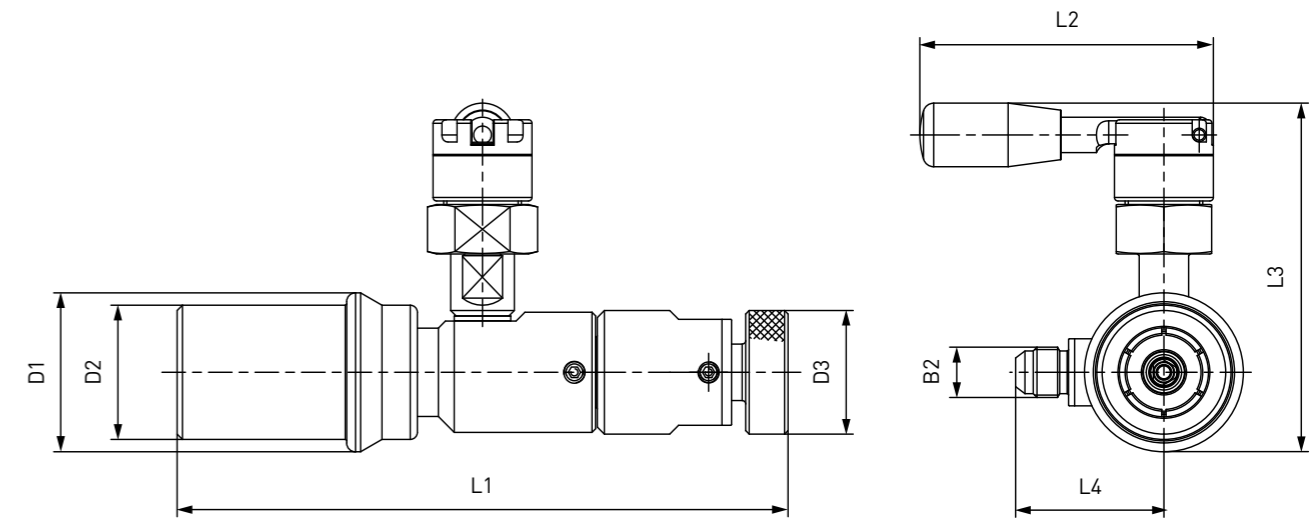

Part No.	Description	Pressure (PS)	B2 (male thread)	L1	L2	L3	L4	D1	D2	D3
C1-104732-X01	TK6 H ₂	45 MPa	UNF 9/16"-18*	min. 173 / max. 180	83	99	42	45	38	35

* acc. to SAE J514, 37° cone

» Defueling nozzle TK6 H₂

ACCESSORIES

The following accessories are available for the WEH® TK6 H₂ Defueling nozzle:

Pressure hose

Pressure hose for connection to the defueling nozzle, complete with fittings and press-fittings supported by coil spring stubs. Not suitable for refueling with pre-cooled hydrogen acc. to SAE J2601. Design hose: max. operating pressure PS: 45 MPa / nominal bore (DN): 4.5 mm / media temperature range: -20 °C up to +90 °C



Part No.	B1/B2 (female thread)	Hose length
E68-60809	UNF 9/16"-18*	3 m
E68-60812	UNF 9/16"-18*	4 m
E68-60813	UNF 9/16"-18*	5 m

* acc. to SAE JIC, 37° cone

WEH® TN1 H₂ Receptacle with tube fitting, without filter

approx. dimensions (mm)

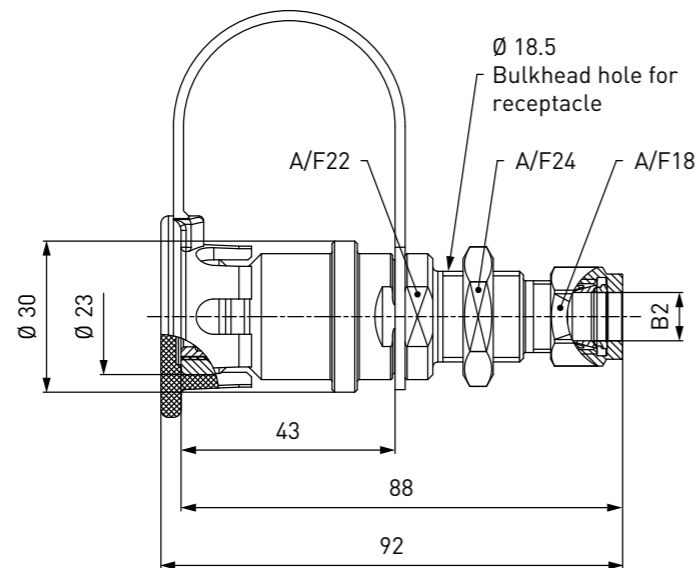

Part No.	Description	DN	Pressure (PS)	B2
C1-18481/4-X01	TN1 H ₂	8	45 MPa	Tube Ø 3/8**
C1-32456	TN1 H ₂ (EC79)	8	45 MPa	Tube Ø 10*

* double ferrule fitting

» Defueling nozzle TK6 H₂

WEH® TNS1 H₂ Service receptacle

To prevent damage in the defueling nozzle while purging or leak testing during maintenance in the course of which pressure is applied, we recommend the use of a service receptacle. The receptacle also protects the defueling nozzle from dirt ingress whilst not in use.



Part no.	Description
C1-157639	TNS1 H ₂ Service receptacle incl. protection cap

SPARE PARTS

Various parts are available as spares for the WEH® TK6 H₂ Defueling nozzle.



Part no.	Description
E80-111760	1 Sliding sleeve
E99-44923	Maintenance spray

» Service receptacle TNS10 H₂

DESCRIPTION



Features

- Integrated shut-off valve
- Low-noise discharging
- Sealing-friendly design
- Incl. protection cap

Vehicles running on hydrogen have to be serviced and checked regularly. Therefore it is necessary that all pressure vessels or fuel tanks are discharged. The WEH[®] TNS10 H₂ Service receptacle has been specially developed for this purpose. It is mounted on the body panel of the hydrogen vehicle and enables easy discharging of the fuel tank.

For the WEH[®] TNS10 H₂ the suitable WEH[®] TW110 H₂ Service connector is also available. The TW110 is simply connected to the service receptacle and discharging can begin. When discharging is complete, the service connector can be disconnected again.

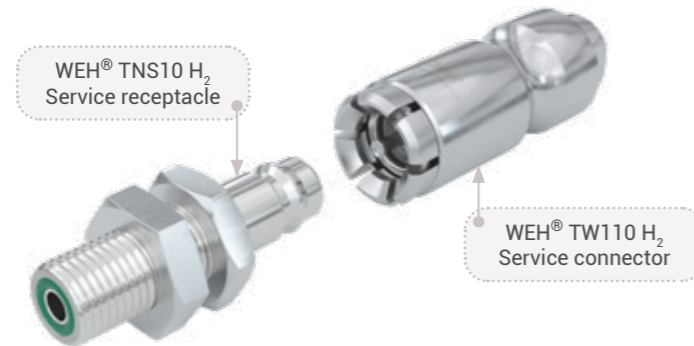

Application

Service receptacle for discharging hydrogen fuel tanks.
 Operation only by specially trained service personnel. Not for self-service operation!
Attention: The TNS10 H₂ may not be used for filling!

Note:

The TNS10 H₂ may only be used in conjunction with a suitable upstream shut-off device or valve (e.g. ball valve)!

TECHNICAL DATA

Characteristics	Basic version
Nominal bore (DN)	6 mm
Pressure range	PN = 1.6 MPa PS = 2 MPa
Temperature range	-40 °C up to +85 °C
Material	Corrosion resistant stainless steel
Sealing material	Hydrogen resistant
Design	Incl. integrated shut-off valve, bulkhead fitting and protection cap

Other designs on request

» Service receptacle TNS10 H₂

ORDERING | WEH[®] TNS10 H₂ Service receptacle

approx. dimensions (mm)

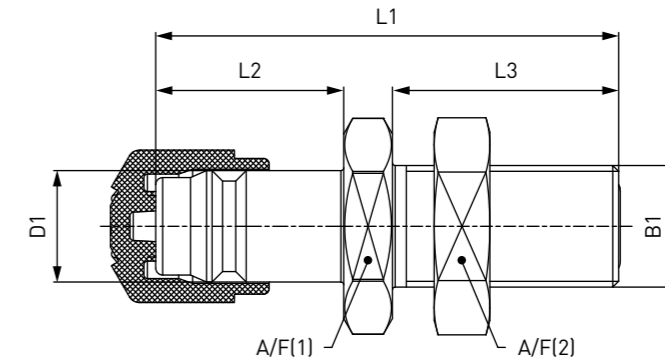

Part No.	Description	DN	Pressure (PS)	B1 (male thread)	L1	L2	L3	D1	A/F(1) / A/F(2)
C1-151481	TNS10 H ₂	6	2 MPa	UN 11/16"-16 for sealing with O-Lok [®] Face Seal* for tube Ø 10 (3/8")	66.5	27	32.5	16	27

* Face Seal acc. to SAE J1453

» Service receptacle TNS10 H₂

ACCESSORIES

The following accessories are available for the WEH® TNS10 H₂ Service receptacle:

WEH® TW110 H₂ Service connector

Service connector with integrated shut-off valve for discharging the pressure vessels and fuel tanks of vehicles running on hydrogen.

approx. dimensions (mm)

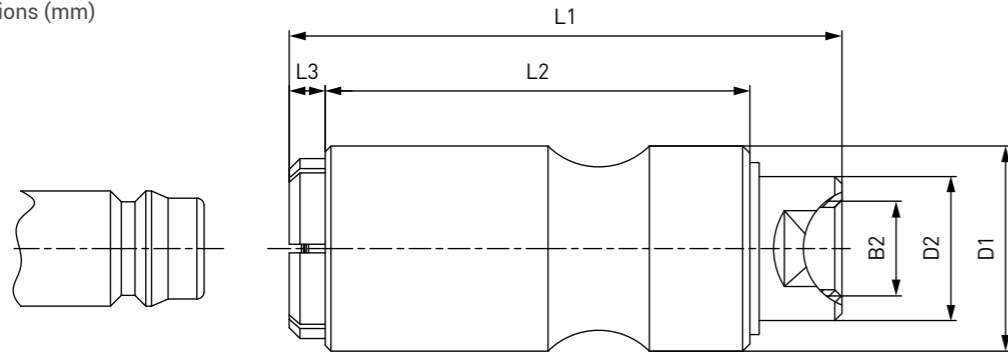

Part No.	Description	DN	Pressure (PS)	B2 (female thread)	L1	L2	L3	D1	D2
C1-84461	TW110 H ₂	8	2 MPa	G1/4"	77	59	5	28.5	20

» Service receptacle TNS10 H₂

SPARE PARTS

Various parts are available as spares for the WEH® TNS10 H₂ Service receptacle.

Protection cap

To protect the TNS10 H₂ service receptacle from dirt ingress and damage whilst not in use.



Part No.	Description
E80-83726	Protection cap

» H₂ Hoses

DESCRIPTION

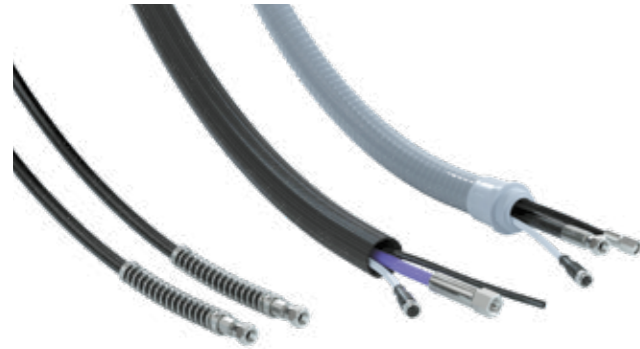

Features

- Different lengths available
- Tailor-made according to customers' specifications

We offer hydrogen hoses for connecting our fueling nozzles to the breakaway coupling or fueling station. The hoses are available with suitable fittings. The hoses or hose sets can be delivered in different standard sizes. On request the hydrogen hoses are also available in other lengths.

Application

Hydrogen hoses / hose sets for installation at the fueling station.

TECHNICAL DATA

Characteristics	Basic version
Max. allowable operating pressure PS	45 MPa (hoses for TK16 H ₂ , TK16 H ₂ High-Flow, TK25 H ₂ , TK6 H ₂) 49 MPa (hoses for TK17 H ₂ , 35 MPa) 87.5 MPa (hoses for TK17 H ₂ , 70 MPa)
Media temperature range	-20 °C up to +90 °C* (hoses for TK16 H ₂ , TK16 H ₂ High-Flow, TK25 H ₂ , TK6 H ₂) -40 °C up to +85 °C (hoses for TK17 H ₂ , 70 MPa, TK17 H ₂ , 35 MPa)
Ambient temperature range	-40 °C up to +85 °C
Sealing material	Hydrogen resistant

* not suitable for refueling with pre-cooled hydrogen acc. to SAE J2601

» H₂ Hoses

ORDERING | Hose set for TK17 H₂, 70 MPa

Hose set for connecting fueling nozzle and TSA1 H₂, 70 MPa breakaway coupling, complete with filling hose and braided protection hose as cover.

Design filling hose:

max. operating pressure PS: 96.25 MPa / nominal bore (DN): 4.5 mm / media temperature range: -40 °C up to +85 °C



Part no.	B1/B2 (female thread)	Hose length
E68-163061	UNF 9/16"-18*	3 m
E68-163062	UNF 9/16"-18*	4 m
E68-163063	UNF 9/16"-18*	5 m

* DKJ 58°

ORDERING | Hose set for TK17 H₂, 70 MPa ENR

Hose set for connecting fueling nozzle and TSA1 H₂, 70 MPa breakaway coupling, complete with filling hose, data cable, purging line and braided protection hose as cover.

Design filling hose:

max. operating pressure PS: 96.25 MPa / nominal bore (DN): 4.5 mm / media temperature range: -40 °C up to +85 °C



Part no.	B1/B2 (female thread)	P1/P2	Hose length
E68-161886	UNF 9/16"-18*	Ø 6	3 m
E68-161887	UNF 9/16"-18*	Ø 6	4 m
E68-161888	UNF 9/16"-18*	Ø 6	5 m

* DKJ 58°

ORDERING | Hose set for TK17 H₂, 35 MPa

Hose set for connecting fueling nozzle and TSA1 H₂ breakaway coupling, complete with filling hose and braided protection hose as cover.

Design filling hose:

max. operating pressure PS: 49 MPa / nominal bore (DN): 4.5 mm / media temperature range: -40 °C up to +85 °C



Part no.	B1/B2 (female thread)	Hose length
E68-174296	UNF 7/16"-20*	3 m
E68-174297	UNF 7/16"-20*	4 m
E68-174298	UNF 7/16"-20*	5 m

* acc. to SAE JIC, 37° sealing cone

» H₂ Hoses

ORDERING | Hose set for TK17 H₂ 35 MPa ENR

Hose set for connecting fueling nozzle and TSA1 H₂ breakaway coupling, complete with filling hose, data cable, purging line and braided protection hose as cover.

Design filling hose:

max. operating pressure PS: 49 MPa / nominal bore (DN): 4.5 mm / media temperature range: -40 °C up to +85 °C



Part no.	B1/B2 (female thread)	P1/P2	Hose length
E68-174299	UNF 7/16"-20*	∅ 6	3 m
E68-174300	UNF 7/16"-20*	∅ 6	4 m
E68-174301	UNF 7/16"-20*	∅ 6	5 m

* acc. to SAE JIC, 37° sealing cone

ORDERING | Hose set for TK16 H₂ (25 MPa / 35 MPa) and TK16 H₂ High-Flow (35 MPa)

Hose set for connecting fueling nozzle and TSA1 H₂ breakaway coupling, complete with filling and venting hose, fittings and press-fittings supported by coil spring stubs. Not suitable for refueling with pre-cooled hydrogen acc. to SAE J2601.

Design filling/venting hose:

max. operating pressure PS: 45 MPa / nominal bore (DN): 4.5 mm / media temperature range: -20 °C up to +90 °C



Part No.	B1/B2 (female thread)	C1/C2 (female thread)	Hose length
C1-60917	UNF 9/16"-18*	UNF 7/16"-20*	3 m
C1-60920	UNF 9/16"-18*	UNF 7/16"-20*	4 m
C1-60923	UNF 9/16"-18*	UNF 7/16"-20*	5 m

* acc. to SAE JIC, 37° cone

ORDERING | Hose set for TK16 H₂ (35 MPa) and TK16 H₂ High-Flow (35 MPa) with data interface

Hose set for connecting fueling nozzle and TSA1 H₂ breakaway coupling, complete with filling and venting hose, hose fittings, plastic spiral hose and cable for data interface.

Not suitable for refueling with pre-cooled hydrogen acc. to SAE J2601.

Design filling/venting hose: max. operating pressure PS: 45 MPa / nominal bore (DN): 4.5 mm (filling hose)

resp. 2 mm (venting hose) / media temperature range: -20 °C up to +90 °C

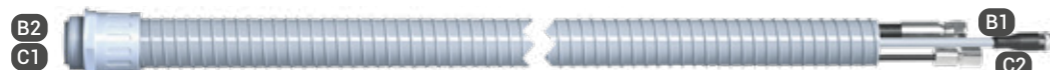

Part No.	B1/B2 (female thread)	C1/C2 (female thread)	Hose length
C1-90698	UNF 9/16"-18*	M12x1.5	3 m
C1-94428	UNF 9/16"-18*	M12x1.5	4 m
C1-94429	UNF 9/16"-18*	M12x1.5	5 m

* acc. to SAE JIC, 37° cone

» H₂ Hoses

ORDERING | Hose set for TK25 H₂ (25 MPa / 35 MPa)

Hose set for connecting fueling nozzle and TSA5 H₂ breakaway coupling, complete with filling and venting hose, fittings and press-fittings supported by coil spring stubs. Not suitable for refueling with pre-cooled hydrogen acc. to SAE J2601.

Design filling/venting hose: max. operating pressure PS: 45 MPa / nominal bore (DN): 5.6 mm (filling hose)

resp. 4.5 mm (venting hose) / media temperature range: -20 °C up to +90 °C



Part No.	B1/B2 (female thread)	C1/C2 (female thread)	Hose length
C1-152556	UNF 7/8"-14*	UNF 9/16"-18*	3 m
C1-152557	UNF 7/8"-14*	UNF 9/16"-18*	4 m
C1-152558	UNF 7/8"-14*	UNF 9/16"-18*	5 m

* acc. to SAE JIC, 37° cone

ORDERING | Pressure hose for TK6 H₂ (35 MPa)

Pressure hose for connecting to the defueling nozzle, complete with fittings and press-fittings supported by coil spring stubs. Not suitable for refueling with pre-cooled hydrogen acc. to SAE J2601.

Design hose:

max. operating pressure PS: 45 MPa / nominal bore (DN): 4.5 mm / media temperature range: -20 °C up to +90 °C



Part No.	B1/B2 (female thread)	Hose length
E68-60809	UNF 9/16"-18*	3 m
E68-60812	UNF 9/16"-18*	4 m
E68-60813	UNF 9/16"-18*	5 m

* acc. to SAE JIC, 37° cone

» Technical appendix

Definitions

Abbreviation	Definition	
Pressure specifications		
PN	Nominal pressure	Nominal pressure after temperature compensation at 15 °C (59 °F)
PS	Max. allowable operating pressure	Maximum allowable operating pressure acc. to Pressure Equipment Directive 2014/68/EU, Article 2 paragraph 8
PT	Hydrostatic test pressure	Hydrostatic test pressure acc. to Pressure Equipment Directive 2014/68/EU, Annex I no. 7.4
PP	Pilot pressure	Actuation pressure for hydraulic and pneumatic components
PC	Cracking pressure	Pressure at which the check valve opens and the first indication of flow occurs
WP	Working pressure	'Working pressure' means the maximum pressure to which a component is designed to be subjected to and which is the basis for determining the strength of the component under consideration
MAWP	Max. allowable working pressure	Max. allowable operating pressure at which the weakest point of the system or the vessel (e.g. cylinder valve) can operate at a certain temperature during normal operation
Dimensions		
L1, L2, L3 ...	Length specification	
D1, D2, D3 ...	Diameter specification	
A/F(1), A/F(2) ...	Wrench size specification	
Ports		
A / X	Customer-specific port (test piece, sample, cylinder valve, handwheel respiratory protective equipment)	
B1, B2, B3 ...	Media ports	
C1, C2, C3 ...	Gas recirculation ports	
P1, P2, P3 ...	Pilot pressure ports	
MA1, MA2 ...	Measuring ports	
Q	Drain port filter	
G	Mounting bores	
Others		
DN	Nominal size (DN) acc. to Pressure Equipment Directive 2014/68/EU, whereby the largest, pressurized diameter of the media or pilot pressure connections of the WEH® Device (A, B1, B2, B3 or C1, C2, C3 and P1, P2, P3) which faces the customer's pipe system, is relevant.	
µm	Max. diameter of the filtered particle	
Kv	Is the discharge of water in m ³ /h at a pressure drop of 1 bar (14.5 psi), acc. to DIN/EN 60534-2	
Cv	Is the discharge of water in gallons per minute at a pressure drop of 1 psi, acc. to DIN/EN 60534-2	
IR	Infrared data interface	
ENR	Exchangeable data interface (exchangeable nozzle receiver)	
TS	Maximum allowable temperature acc. to Pressure Equipment Directive 2014/68/EU, Article 2 paragraph 9	

» Technical appendix

Definitions

Abbreviation	Definition
Breakaway force	Is the force range, in which the breakaway releases
NC	Normally closed (initial position of shut-off valve)
NO	Normally open (initial position of shut-off valve)

Technical explanations

Term	Definition
Temperature range	Is the temperature range in which the WEH® Product can be used. If no explicit information on medium and ambient temperature is given, this temperature range applies to both medium and environment.
Media temperature range	Is the temperature range of the medium used, which can flow through the WEH® Product (may change depending on the time of measurement).
Ambient temperature range	Is the temperature range of the environment in which the WEH® Product can be used.
Leak rate	Is the maximum external leak rate, which the WEH® Product exhibits in delivery condition.
Internal leak rate	The internal leak rate depends, among other things, on type of application, medium and pressure difference on the WEH® Product. On request it can be specified more precisely.
Max. side load	Is the max. allowable sum of all external forces that may act on the device under intended use. Note: External forces can affect the life time of WEH® Products and can cause damage. Tensile and transverse loads as well as vibrations and pressure impacts need to be considered, e.g. by user side measures such as on site mountings and similar. Therefore, lateral forces such as whipping hoses or other equipment must be avoided. WEH® Products should be installed in such a way, that lateral forces which could lead to leakage or damage can not occur. Special applications require a special consultation before selecting the product.
Products with pneumatic actuation	The customer has to ensure there is adequate axial movement when pneumatically actuated WEH® Products are used in automated systems, see maximum side load. Ideally the products should be mounted with a floating joint or introduced individually to prevent the possibly existing clamping jaws getting blocked or jammed in the thread of the test piece.
Sealing material	On request the WEH® Product can be adapted to customer specific applications regarding to the sealing materials used. The clarification of the media compatibility and suitability of the adapted WEH® Product for the final application is always the responsibility of the end user.
Corrosion resistant	WEH® Products are designed for use in temperate climate zones - with low levels of humidity and salinity in the air. An accelerated formation of rust or corrosion may occur at or near the sea. Therefore, reduce the inspection interval recommended for normal use and send in the WEH® Product for maintenance immediately if you notice increased soot, rust or corrosion.
Storage / life time of components	There are certain requirements for every WEH® Product. WEH® Products are generally products which may be subject to wear and fatigue during operation and depending on your individual application/use. For details - in particular regarding the corresponding minimum inspection and maintenance intervals - please refer to the respective operating instructions for the WEH® Product.

» Technical appendix

Further explanations

Subject	Definition
Technical data	Unless otherwise stated, the technical data in catalogs, data sheets and operating instructions are based on tests with nitrogen that are in the development phase or at the end of development. Leakage data are based on measurements with helium.
Intended use	For the intended use of WEH® Products, please refer to the respective operating instructions. The following applications are generally excluded for WEH® H ₂ and CNG products, unless these are expressly permitted in the operating instructions: <ul style="list-style-type: none"> • aerospace applications, e.g. in aircrafts • shipping applications • applications offshore and in littoral areas • applications within defense and weapons technology
Safe product selection	Our WEH® Products are designed to be operated by qualified professional users (insofar as WEH® Products are also designed to be operated by other users in individual cases, this is explicitly stated in the corresponding operating instructions). Please note that WEH does not know your system and therefore - also due to the large number of different potential applications of WEH® Products - cannot perform tests on all potential types of application. You alone are responsible for the selection, configuration and suitability of WEH® Products, especially according to the requirements of your system. Before purchasing WEH® Products, please particularly ensure that our products are compatible with your intended use, your performance data, your material and fluids, your system concept and your system limits according to our product specifications. Please also consider your technical and legal requirements for operation, handling and maintenance. The quality and safety of WEH® Products is our highest priority. For this reason, WEH® Products may not be used outside the specifications in the relevant data sheets and product descriptions. If you are not sure whether the WEH® Product is suitable for your system and intended use, please contact us in advance. We also strongly recommend that you refrain from using third-party spare parts or a combination of WEH® Products with unsuitable third-party products. You alone are responsible for reviewing the suitability of third-party products. WEH® Products and WEH® Spare parts comply with our quality and safety standards.
Explanation on the Pressure Equipment Directive	In general, WEH® Products with a maximum allowable operating pressure of more than 0.5 bar (PS) fall within the scope of application of the Pressure Equipment Directive 2014/68/EU, are generally classified as pressure accessories in accordance with Article 2 (5) of the same and are considered to be similar to piping. These WEH® Products may not be used as safety accessories. Furthermore, it is pointed out, that these WEH® Products are designed and placed on the market in accordance with the requirements of Article 4 (3) of the Pressure Equipment Directive 2014/68/EU. For some products a different classification and/or categorisation is required or can be conducted on request. In these cases, if legally required, a conformity assessment procedure in accordance with Annex III of the Pressure Equipment Directive 2014/68/EU can and will also be conducted and the conformity can be declared by means of an EU Declaration of Conformity in accordance with Annex IV of the Pressure Equipment Directive 2014/68/EU. In these cases, the EU Declaration of Conformity is enclosed with the product.
External change management	WEH reserves the right to update, optimise and adjust its products continuously. This may result in corresponding changes of the product. Customers will be informed proactively or unsolicited by WEH only in individual cases about product updates, product optimisations and/or product adaptations that have been carried out. You are free to contact WEH at any time to request information about any product updates, product optimisations and/or product adjustments.

» Brochure data

This catalog was created diligently and on the basis of decades of experience.

All information/recommendations in this catalog are non-binding and are particularly subject to possible deviations or changes. For any binding information/recommendations, please refer to the verified information/recommendations in our individual orders. Particularly, due to the wide range of possible applications of WEH® Products and the unknown parameters and operating conditions linked to them, the accuracy and/or completeness of the information/recommendations in this catalog cannot be guaranteed with respect to certain individual cases. In doing so, we would like to refer once again to the information/recommendations provided in individual orders.

The application limits indicated in this catalog (e.g. for pressure, temperature, etc.) are generally theoretical values determined in a test environment. As the concrete operating conditions could differ, we cannot ensure that these values apply to a specific customer application. During the practical use, you should particularly consider that the mutual influence of operational parameters could result in changes of the maximum values. Especially, in case of any unusual operating conditions, please contact WEH before using any WEH® Products. We therefore strongly recommend that you also require any necessary binding information/recommendations to be included by us in the individual orders.

Furthermore, we point out that we cannot assume any warranty or accept any responsibility for printing errors, incomplete information or misinterpretations. Illustrations and/or images are particularly provided for illustrative purposes only and may differ in some details from the actual product. Moreover, dimensions and other technical details in this catalog are non-binding information and are provided for illustrative purposes only. The product's exact form and design result exclusively from the specific individual order. In particular, certain information/recommendations in the catalog only become integral part of the contract if they have been expressly contractually agreed.

Only the latest version of our catalog and other product related documents is valid and applicable. Please ensure that you always use the latest catalog's and documents' versions. Please feel free to contact WEH at any time and request the latest versions.

Our General Terms and Conditions and the Agreement on Protection of Know-How and Quality Assurance shall apply to deliveries and other services, unless expressly agreed otherwise.

In principle, we do not accept the General Terms and Conditions of our customers or third parties. Thank you for your understanding.

WEH Official Sales Partner

METALIKA KACIN | Slovenija

Address: KACIN JOŽICA s.p. METALIKA
Bedrih 27
SI-4226 ŽIRI

Office: Biro / Warehouse ŽIRI
Račeva 8
SI-4226 ŽIRI

Phone: (+386) 041 / 694 339
Email: info@metalika-kacin.com

METALIKA KACIN | Srbija

Address: METALIKA KACIN d.o.o.
Kir Janjina 2
RS-11253 SREMČICA

Phone: (+381) 011 / 25 21 756
Mobile: (+381) 062 / 311 768
Email: srbija@metalika-kacin.com

METALIKA KACIN | Hrvatska

Address: KACIN METALIKA d.o.o.
Radićeva 18
HR-51000 RIJEKA

Phone: (+385) 051 / 213 060
Mobile: (+385) 091 / 58 70 744
Email: hrvatska@metalika-kacin.com

Design and production

WEH GmbH Gas Technology
Josef-Henle-Str. 1
89257 Illertissen / Germany

Phone: +49 7303 95190-0
E-Mail: h2sales@weh.com
Website: www.weh.com

More questions? – Great! Don't hesitate to contact our experts.