



THRUST PADS / CLAMPING PADS

DIN 6379
Studs
 for T-Nuts



page 937

DIN 6311
Thrust pads
 for Grub screws
 DIN 6332, for Tommy
 screws DIN 6304 /
 DIN 6306



page 938

GN 6311.1
Thrust pads
 for grub screws
 DIN 6332, tommy
 screws DIN 6304 /
 DIN 6306



page 939

GN 631
Thrust pads
 for Grub screws
 GN 632.1 / GN 632.5



page 940

GN 631.5
**Stainless Steel-Thrust
 pads**
 for Grub screws
 GN 632.5



INOX
 STAINLESS
 STEEL

page 941

GN 346
Ball joint thrust pads



page 942

GN 347
**Hexagon nuts with
 ball socket**



page 942

GN 709.1
**Clamping pads
 with threaded stud**



page 943

GN 709.2
**Clamping pads
 with female thread**



page 944

GN 709.3
**Clamping pads
 adjustable**



page 945

GN 709.15
**Stainless Steel-
 Clamping pads
 with threaded stud**



INOX
 STAINLESS
 STEEL

page 946

GN 709.25
**Stainless Steel-
 Clamping pads
 with female thread**



INOX
 STAINLESS
 STEEL

page 946

GN 709.35
**Stainless Steel-
 Clamping pads
 adjustable**



INOX
 STAINLESS
 STEEL

page 947

GN 709.6
**Clamping pads
 adjustable**



page 948

GN 709.7
**Clamping pads
 with female thread**



page 949

GN 709.8
**Clamping pads
 adjustable**



page 950

GN 709.9
**Clamping pads
 adjustable**

page 951

GN 709.10
**Clamping pads
 adjustable**

page 952

GN 709.11
**Clamping pads
 adjustable**

page 950

GN 709.12
**Stainless Steel-
 Clamping pads
 adjustable**

INOX
 STAINLESS
 STEEL

page 952

GN 709.13
**Clamping pads
 adjustable**

page 950

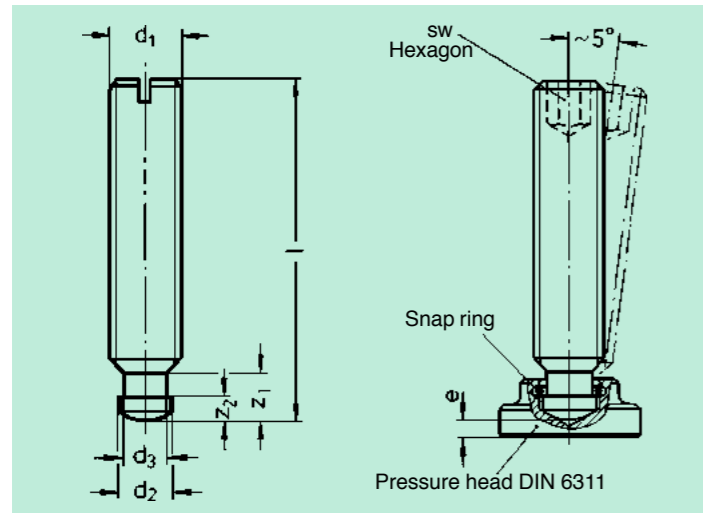

Thread Pins with Pressure Point, DIN 6332

INOX



The pressure point of thread pin DIN 6332 is designed to be used with or without the pressure head. The snap ring of the pressure head provides simple and fast connection between screw and pressure head.

Model: Steel, stability class 5.8, black oxide finished. Pressure point hardened.

Type S: with slot

Type SK: with internal hexagon

Thread Pins with Pressure Point DIN 6332

Order No.	Order No.	d ₁	Length of Screw l (mm)			d ₂ h ₁₁	d ₃	e	sw	z ₁	z ₂
Type S	Type SK					mm	mm	mm	mm	mm	mm
50 06 ... S	50 06 ... SK	M 6	30	40	50	4,5	4	2,2	3	5,4	2,5
50 08 ... S	50 08 ... SK	M 8		40	50	6	5,4	3	4	6,8	3
50 10 ... S	50 10 ... SK	M 10			60	8	7,2	3,6	5	8,2	4,5
50 12 ... S	50 12 ... SK	M 12			60	8	7,2	4,5	6	8,6	4,5
50 16 ... S	50 16 ... SK	M 16			80	10	11	5,3	8	10,6	5
50 20 ... S	50 20 ... SK	M 20			100	12,5	14,4	5,6	10	12,4	5,5

... Please indicate here the desired length of screw, e.g. 030 for l = 30 mm.

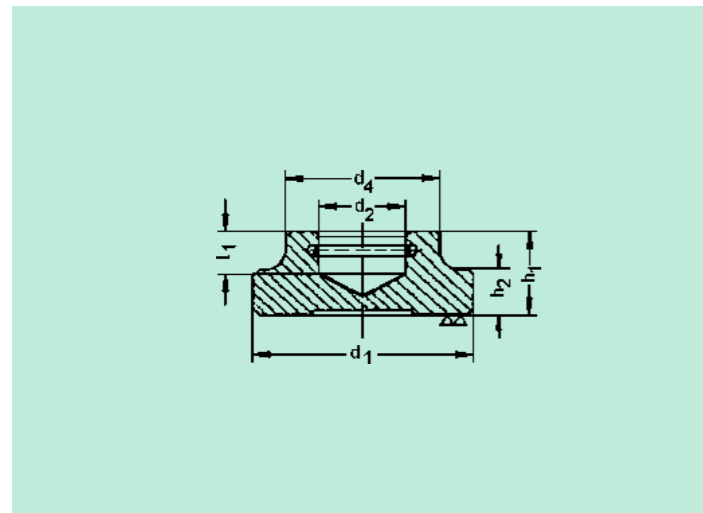

Pressure Heads DIN 6311



Pressure heads can be connected with pressure point screws (Thread Pins DIN 6332) to transmit the applied tension force. It is also suitable for uneven or non-parallel surfaces and prevent any screw turning movements to the workpiece.

Model: Blank turned, insert hardened. Snap ring inlaid.

Pressure Heads DIN 6311

Order No.	used Thread Pin	d ₁ mm	d ₂ H ₁₂ mm	d ₄ mm	h ₁ mm	h ₂ mm	t ₁ mm
53 12 06	M 6	12	4,6	10	7	2,5	4
53 16 08	M 8	16	6,1	12	9	4	5
53 20 10	M 10	20	8,1	15	11	5	6
53 25 12	M 12	25	8,1	18	13	6	7
53 32 16	M 16	32	12,1	22	15	7	7,5
53 40 20	M 20	40	15,6	28	16	9	8



Thrust pads

for grub screws DIN 6332, tommy screws DIN 6304 / DIN 6306

SPECIFICATION

Types

- Type **A**: Thrust pad surface plain, without plastic cap
- Type **P**: Thrust pad surface with prism, without plastic cap
- Type **K**: Thrust pad surface plain, with plastic cap

Steel

blackened

Snap ring

Spring steel wire

Plastic cap (Polyacetal POM)

- natural colour

- temperature resistant up to 100 °C



INFORMATION

Thrust pads GN 6311.1 are used in conjunction with grub screws fitted with thrust point (grub screws DIN 6332 (see page 912), tommy screws DIN 6304 (see page 407) and DIN 6306 (see page 409) to transmit clamping force. They align themselves on uneven and non-parallel surfaces and thus prevent the rotating force being transmitted to the workpiece.

The plastic cap prevents damage to delicate workpieces.

The unique shape of the non-removable retaining ring permits easy insertion and removal of grub screws into or from the thrust pad.

Thrust pads GN 6311.1 can be used in conjunction with DIN 6332 (see page 912) grub screws as levelling pad.

TECHNICAL INFORMATION

- Plastic characteristics (see page A2)

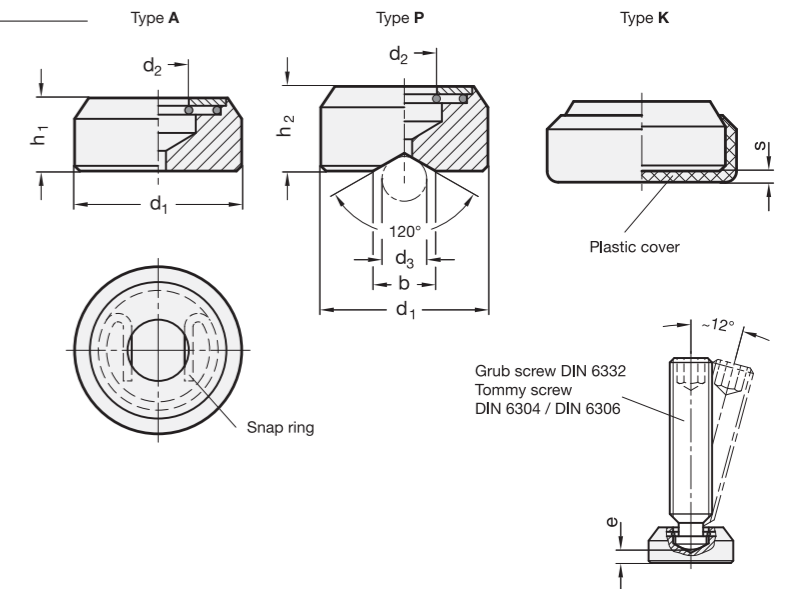

GN 6311.1

Description	d ₁	b	d ₂ +0.2	d ₃ min.	d ₃ max.	e ≈	h ₁	h ₂	s	Grub screw DIN 6332	⚖
GN 6311.1-16-A	16	10	6.3	7.5	20	2.2	8	-	1.5	M 8	11
GN 6311.1-20-A	20	12	9.2	7.5	24	2.6	10	-	1.5	M 10 M 12	18
GN 6311.1-25-A	25	16	9.2	7.5	32	2.9	11	-	1.5	M 10 M 12	34
GN 6311.1-32-A	32	22	12.5	7.5	44	4.5	14	-	1.5	M 16	70
GN 6311.1-16-P	16	10	6.3	7.5	20	5.3	-	11	1.5	M 8	13
GN 6311.1-20-P	20	12	9.2	7.5	24	5.6	-	13	1.5	M 10 M 12	24
GN 6311.1-25-P	25	16	9.2	7.5	32	6.9	-	15	1.5	M 10 M 12	43
GN 6311.1-32-P	32	22	12.5	7.5	44	9.2	-	18	1.5	M 16	80
GN 6311.1-16-K	16	10	6.3	7.5	20	-	8	-	1.5	M 8	12
GN 6311.1-20-K	20	12	9.2	7.5	24	-	10	-	1.5	M 10 M 12	22
GN 6311.1-25-K	25	16	9.2	7.5	32	-	11	-	1.5	M 10 M 12	35
GN 6311.1-32-K	32	22	12.5	7.5	44	-	14	-	1.5	M 16	74

Thrust pads

for Grub screws GN 632.1 / GN 632.5

SPECIFICATION

Plastic
 Technopolymer (Polyacetal POM)
 - temperature resistant up to 80 °C
 - black, matt

INFORMATION

Thrust pads GN 631 with ball point grub screw GN 632.1 (see page 914) / GN 632.5 (see page 915) are ideal to transmit clamping forces. They lean to uneven and unparallel surfaces. They are easy to press-on to the ball point of the grub screw by hand.



Mounting example

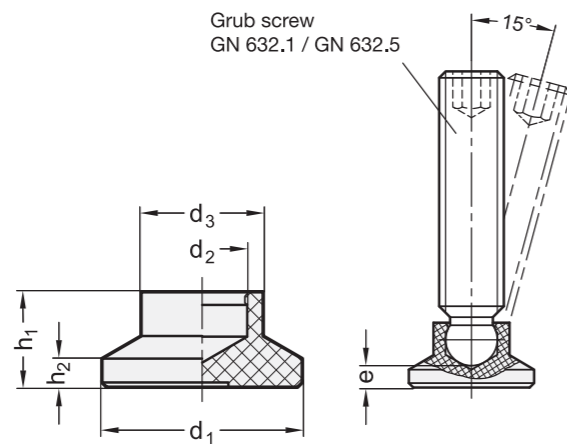

GN 631

Description	d1	d2	d3	e ≈	h1	h2	Grub screw GN 632.1/ GN 632.5	⚖
GN 631-15-4,5	15	4,5	8,6	3,6	7,6	2,5	M 6	2
GN 631-15-6,1	15	6,1	8,6	2,5	7,6	2,5	M 8	2
GN 631-18-4,5	18	4,5	10,8	5,2	9,2	2,5	M 6	3
GN 631-18-6,1	18	6,1	10,8	4,2	9,2	2,5	M 8	3
GN 631-18-7,8	18	7,8	10,8	3,8	9,2	2,5	M 10	3
GN 631-21-4,5	21	4,5	12,8	6	10	3	M 6	4
GN 631-21-6,1	21	6,1	12,8	5	10	3	M 8	4
GN 631-21-7,8	21	7,8	12,8	4,3	10	3	M 10	4
GN 631-21-9,4	21	9,4	12,8	3,4	10	3	M 12	4
GN 631-25-4,5	25	4,5	13	6,5	10,5	3	M 6	4
GN 631-25-6,1	25	6,1	13	5,5	10,5	3	M 8	4
GN 631-25-7,8	25	7,8	13	4,6	10,5	3	M 10	4
GN 631-25-9,4	25	9,4	13	3,6	10,5	3	M 12	4
GN 631-32-4,5	32	4,5	14	7	11	3	M 6	6
GN 631-32-6,1	32	6,1	14	6	11	3	M 8	6
GN 631-32-7,8	32	7,8	14	5	11	3	M 10	6
GN 631-32-9,4	32	9,4	14	4,2	11	3	M 12	6
GN 631-40-6,1	40	6,1	16	8	13	4	M 8	11
GN 631-40-7,8	40	7,8	16	7	13	4	M 10	11
GN 631-40-9,4	40	9,4	16	6,2	13	4	M 12	11

Stainless Steel-Thrust pads

for Grub screws GN 632.5

SPECIFICATION

Stainless Steel AISI 303
 O-Ring rubber FPM (Vition®)
 temperature resistant up to 200 °C

INFORMATION

Thrust pads GN 631.5 with ball point grub screw GN 632.5 (see page 915) are ideal to transmit clamping forces. They lean to uneven and unparallel surfaces. They are easy to press-on to the ball point of the grub screw by hand.

TECHNICAL INFORMATION

- Stainless Steel characteristics (see page A26)



Mounting example

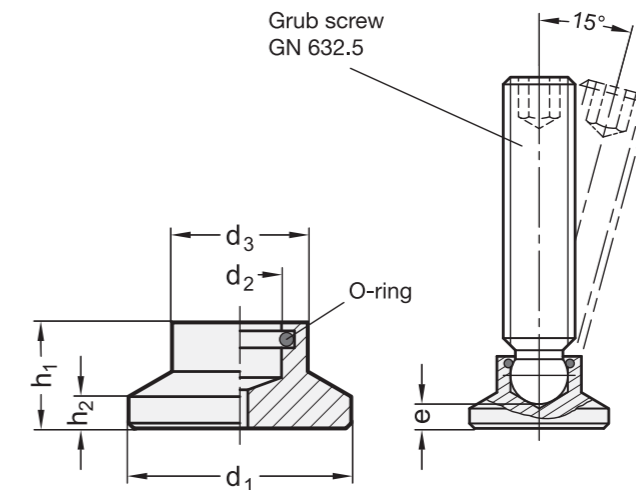

GN 631.5

STAINLESS STEEL

Description	d1	d2	d3	e ≈	h1	h2	Grub screw GN 632.5	⚖
GN 631.5-21-4,5	21	4,5	12,8	6	10	3	M 6	17
GN 631.5-21-6,1	21	6,1	12,8	5	10	3	M 8	17
GN 631.5-21-7,8	21	7,8	12,8	4,3	10	3	M 10	16
GN 631.5-21-9,4	21	9,4	12,8	3,4	10	3	M 12	14
GN 631.5-25-4,5	25	4,5	13	6,5	10,5	3	M 6	23
GN 631.5-25-6,1	25	6,1	13	5,5	10,5	3	M 8	21
GN 631.5-25-7,8	25	7,8	13	4,6	10,5	3	M 10	21
GN 631.5-25-9,4	25	9,4	13	3,6	10,5	3	M 12	21
GN 631.5-32-4,5	32	4,5	14	7	11	3	M 6	35
GN 631.5-32-6,1	32	6,1	14	6	11	3	M 8	35
GN 631.5-32-7,8	32	7,8	14	5	11	3	M 10	34
GN 631.5-32-9,4	32	9,4	14	4,2	11	3	M 12	33
GN 631.5-40-6,1	40	6,1	16	8	13	4	M 8	68
GN 631.5-40-7,8	40	7,8	16	7	13	4	M 10	68
GN 631.5-40-9,4	40	9,4	16	6,2	13	4	M 12	66

GN 346



Ball joint thrust pads

SPECIFICATION

- Steel
- Tensile strength class 5.8
- zinc plated, blue passivated

INFORMATION

Ball joint thrust pads GN 346 are in general used for transfer of clamping forces. They adjust themselves to uneven or non-parallel surfaces and clamp without twisting the clamped parts.

The values were arrived at by a series of tests whereby a limited number of ball joint pads were subjected for a limited time to a vertical static load to the pads.

At the values given in the table a permanent deformation of the ball is almost impossible.

Ball joint thrust pads GN 346 can also be used as levelling feet with a small foot diameter.

TECHNICAL INFORMATION

- Strength values of nuts (see page A20)

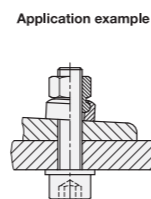
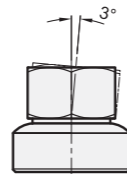
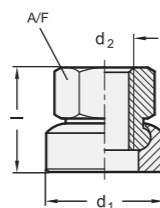
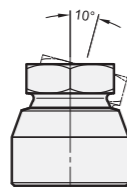
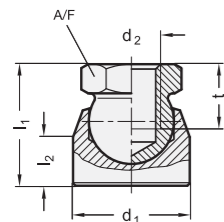

GN 346

Description	d1	d2	l1 ≈	l2	t min.	A/F	Static load in kN	⚖️
GN 346-16-M8	16	M 8	19	7	9	12	5	20
GN 346-20-M10	20	M 10	22	8	11	15	7.5	35
GN 346-24-M12	24	M 12	25	10	12	17	10	50
GN 346-30-M16	30	M 16	34	13	16	24	15	115

GN 347



Hexagon nuts with ball socket

SPECIFICATION

- Steel
- Tensile strength class 10
- blackened

INFORMATION

Hexagon nuts with ball socket GN 347 are capable of clamping slanting surfaces up to 3° without disturbing / twisting the clamped surface.

TECHNICAL INFORMATION

- Strength values of nuts (see page A20)

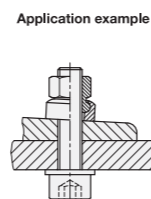
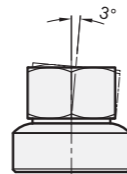
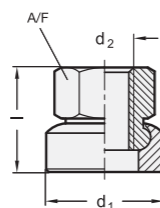

GN 347

Description	d1	d2	l ≈	A/F	⚖️
GN 347-17-M8	17	M 8	14	13	13
GN 347-21-M10	21	M 10	17.5	16	25
GN 347-24-M12	24	M 12	21.5	18	38
GN 347-30-M16	30	M 16	28	24	76
GN 347-36-M20	36	M 20	35	30	141
GN 347-44-M24	44	M 24	42.5	36	262

GN 709.1



Clamping pads with threaded stud

SPECIFICATION

Types

- Type **B**: Smooth contact face
- Type **R**: Serrated contact face

Steel

- tempered
- phosphated

Ball

Steel

- hardened
- blank

INFORMATION

Clamping pads GN 709.1 are used as mobile supports or as spring plungers for clamping workpieces. They can also be used as a back stop.

The ball is limited to an angular movement of 9° only.

TECHNICAL INFORMATION

- ISO-Fundamental Tolerances (see page A21)

ON REQUEST

- Serrated hard metal ball

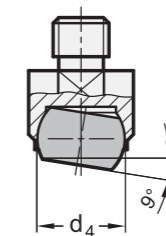
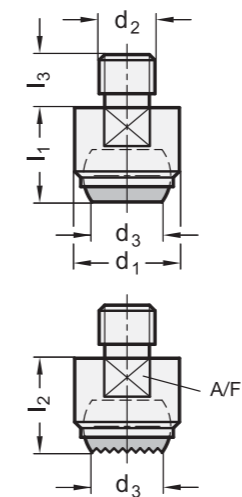

Application example when used as a workpiece support

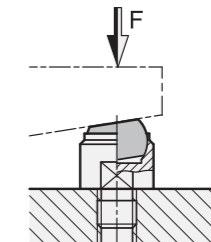

GN 709.1

Description	d1	d2	d3	d4	l1 ±0.02	l2 ±0.1	l3	A/F	Static load max. in kN	⚖️
GN 709.1-13-M6-B	13	M 6	7.2	10	13	-	8	11	10	13
GN 709.1-13-M8-B	13	M 8	7.2	10	13	-	8	11	10	13
GN 709.1-20-M8-B	20	M 8	10.5	16	18	-	10	17	25	39
GN 709.1-20-M10-B	20	M 10	10.5	16	18	-	10	17	25	41
GN 709.1-20-M12-B	20	M 12	10.5	16	18	-	12	17	25	51
GN 709.1-30-M16-B	30	M 16	20	25	27	-	16	27	90	151
GN 709.1-50-M20-B	50	M 20	34.5	40	35	-	20	41	165	521
GN 709.1-13-M6-R	13	M 6	7.2	10	-	13	8	11	10	13
GN 709.1-13-M8-R	13	M 8	7.2	10	-	13	8	11	10	14
GN 709.1-20-M8-R	20	M 8	10.5	16	-	18	10	17	25	39
GN 709.1-20-M10-R	20	M 10	10.5	16	-	18	10	17	25	41
GN 709.1-20-M12-R	20	M 12	10.5	16	-	18	12	17	25	41
GN 709.1-30-M16-R	30	M 16	20	25	-	27	16	27	90	151
GN 709.1-50-M20-R	50	M 20	34.5	40	-	35	20	41	165	521



Clamping pads

with female thread

SPECIFICATION

Types

- Type **B**: Smooth contact face
- Type **R**: Serrated contact face

Steel

- tempered
- phosphated

Ball

Steel

- hardened
- blank

INFORMATION

Clamping pads GN 709.2 are used as mobile supports or as spring plungers for clamping workpieces. They can also be used as a back stop.

The ball is limited to an angular movement of 9° only.

TECHNICAL INFORMATION

- ISO-Fundamental Tolerances (see page A21)

ON REQUEST

- Serrated hard metal ball

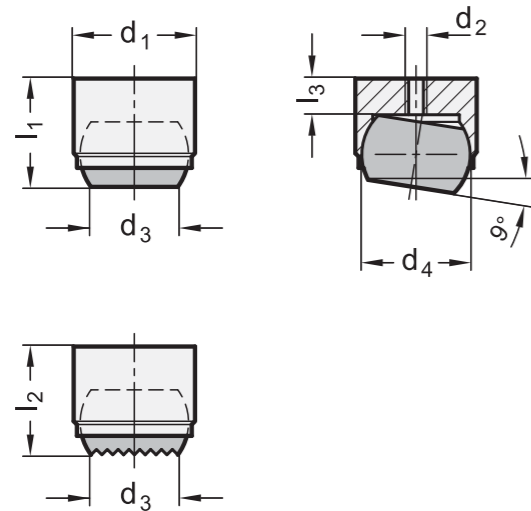

Application example when used as spring plunger

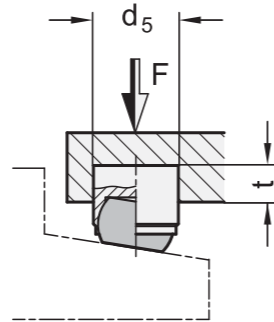

GN 709.2

Description	d1 n6	d2	d3	d4	d5 H7	l1 ±0.02	l2 ±0.1	l3 max.	t min. For max. static load	Static load max. in kN	⚖
GN 709.2-12-B	12	M3	7.2	10	12	11	-	3.2	6	10	9
GN 709.2-18-B	18	M4	10.5	16	18	17	-	4	8	25	31
GN 709.2-28-B	28	M5	20	25	28	25	-	5.5	13	90	81
GN 709.2-12-R	12	M3	7.2	10	12	-	11	3.2	6	10	11
GN 709.2-18-R	18	M4	10.5	16	18	-	17	4	8	25	31
GN 709.2-28-R	28	M5	20	25	28	-	25	5.5	13	90	81



Clamping pads

adjustable

SPECIFICATION

Types

- Type **B**: Smooth contact face
- Type **R**: Serrated contact face

Steel

- tempered
- phosphated

Ball

Steel

- hardened
- blank

Hexagon nut

ISO 4035 (DIN 439)

Steel, blackened



INFORMATION

Clamping pads GN 709.3 are used as mobile supports or as spring plungers for clamping workpieces. They can also be used as a back stop.

The ball is limited to an angular movement of 9° only.

ON REQUEST

- Serrated hard metal ball

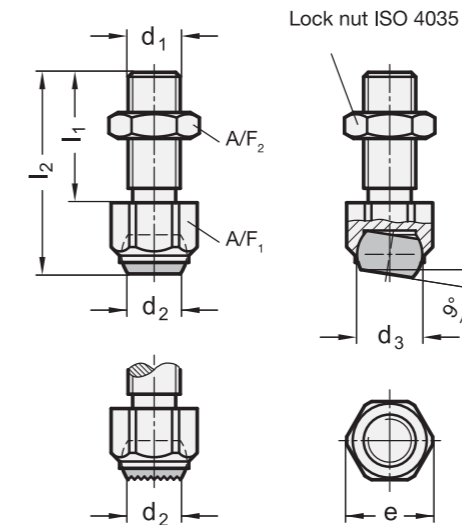

Application example of different clamping pads

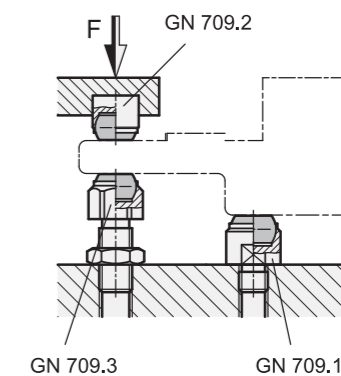

GN 709.3

Description	A/F 1	d1	d2	d3	e	l1	l2	A/F 2	Static load max. in kN	⚖
GN 709.3-13-M8-B	13	M8	5.8	8.5	14.5	25	36.6	13	8	21
GN 709.3-17-M10-B	17	M10	8.6	12	19	30	45.7	17	8	55
GN 709.3-17-M12-B	17	M12	8.6	12	19	35	50.7	19	15	55
GN 709.3-24-M16-B	24	M16	10.5	16	27	40	60.7	24	25	115
GN 709.3-30-M20-B	30	M20	20	25	33	50	77.3	30	90	230
GN 709.3-36-M24-B	36	M24	20	25	40	70	100	36	90	435
GN 709.3-13-M8-R	13	M8	5.8	8.5	14.5	25	36.6	13	8	25
GN 709.3-17-M10-R	17	M10	8.6	12	19	30	45.7	17	8	55
GN 709.3-17-M12-R	17	M12	8.6	12	19	35	50.7	19	15	55
GN 709.3-24-M16-R	24	M16	10.5	16	27	40	60.7	24	25	115
GN 709.3-30-M20-R	30	M20	20	25	33	50	77.3	30	90	230
GN 709.3-36-M24-R	36	M24	20	25	40	70	100	36	90	435

GN 709.15



Stainless Steel-Clamping pads with threaded stud

SPECIFICATION

Type

- Type **B**: Smooth contact face

Stainless Steel AISI 431 tempered

Ball
Stainless Steel AISI 420C nickel plated

INFORMATION

Clamping pads GN 709.15 are used as mobile supports or as spring plungers for clamping workpieces. They can also be used as a back stop.

The ball is limited to an angular movement of 9° only.

TECHNICAL INFORMATION

- Stainless Steel characteristics (see page A26)

ON REQUEST

- Serrated hard metal ball

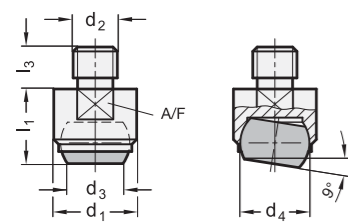

Application example when used as a workpiece support

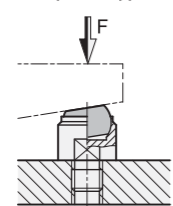

GN 709.25



Stainless Steel-Clamping pads with female thread

SPECIFICATION

Type

- Type **B**: Smooth contact face

Stainless Steel AISI 431 tempered

Ball
Stainless Steel AISI 420C nickel plated

INFORMATION

Clamping pads GN 709.25 are used as mobile supports or as spring plungers for clamping workpieces. They can also be used as a back stop.

The ball is limited to an angular movement of 9° only.

TECHNICAL INFORMATION

- Stainless Steel characteristics (see page A26)

ON REQUEST

- Serrated hard metal ball

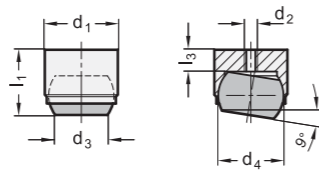

Application example when used as spring plunger

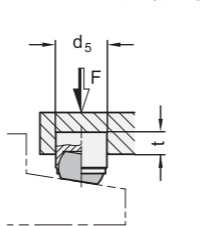

GN 709.15

STAINLESS STEEL

Description	d1	d2	d3	d4	l1 ±0.02	l3	A/F	Static load max. in kN	⚖️
GN 709.15-13-M6-B	13	M 6	7.2	10	13	8	11	10	14
GN 709.15-13-M8-B	13	M 8	7.2	10	13	8	11	10	14
GN 709.15-20-M8-B	20	M 8	10.5	16	18	10	17	25	39
GN 709.15-20-M10-B	20	M 10	10.5	16	18	10	17	25	41
GN 709.15-20-M12-B	20	M 12	10.5	16	18	12	17	25	44
GN 709.15-30-M16-B	30	M 16	20	25	27	16	27	90	151
GN 709.15-50-M20-B	50	M 20	34.5	40	35	20	41	165	280

GN 709.25

STAINLESS STEEL

Description	d1 n6	d2	d3	d4	d5 H7	l1 ±0.02	l3 max.	t min. For max. static load	Static load max. in kN	⚖️
GN 709.25-12-B	12	M 3	7.2	10	12	11	3.2	6	10	9
GN 709.25-18-B	18	M 4	10.5	16	18	17	4	8	25	29
GN 709.25-28-B	28	M 5	20	25	28	25	5.5	13	90	108

GN 709.35



Stainless Steel-Clamping pads adjustable

SPECIFICATION

Type

- Type **B**: Smooth contact face

Stainless Steel AISI 431 tempered

Ball
Stainless Steel AISI 420C nickel plated

Hexagon nut
ISO 4035 (DIN 439)
Stainless Steel

INFORMATION

Clamping pads GN 709.35 are used as mobile supports or as spring plungers for clamping workpieces. They can also be used as a back stop.

The ball is limited to an angular movement of 9° only.

TECHNICAL INFORMATION

- Stainless Steel characteristics (see page A26)

ON REQUEST

- Serrated hard metal ball

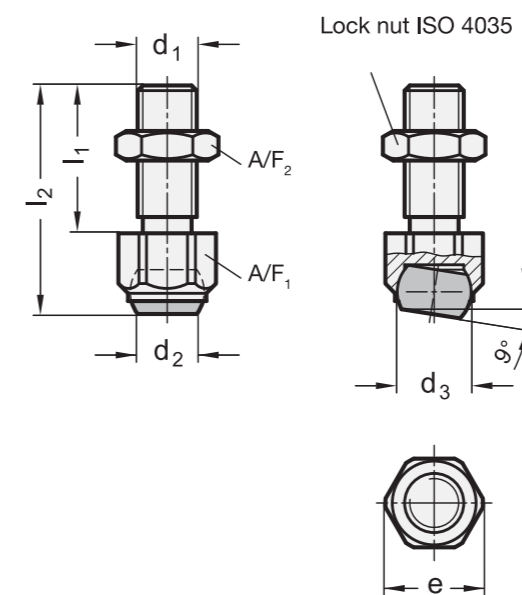

Application example of different clamping pads

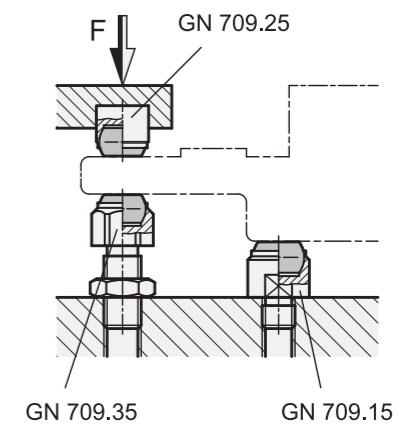

GN 709.35

STAINLESS STEEL

Description	A/F 1	d1	d2	d3	e	l1	l2	A/F 2	Static load max. in kN	⚖️
GN 709.35-13-M8-B	13	M 8	5.8	8.5	14.5	25	36.6	13	8	20
GN 709.35-17-M10-B	17	M 10	8.6	12	19	30	45.7	17	8	44
GN 709.35-17-M12-B	17	M 12	8.6	12	19	35	50.7	19	15	56
GN 709.35-24-M16-B	24	M 16	10.5	16	27	40	60.7	24	25	128
GN 709.35-30-M20-B	30	M 20	20	25	33	50	77.3	30	90	271

Clamping pads adjustable

SPECIFICATION

Types

- Type **B**: Ball steel, smooth contact face
- Type **R**: Ball steel, serrated contact face
- Type **K**: Ball plastic, smooth contact face

Steel

- tempered
- Tensile strength class 10.9

Ball

- Type B and R:
Steel hardened (54+2 HRC)
- Type K:
Plastic (Polyacetal POM)
- O-Ring
Rubber NBR (Perbunan)

INFORMATION

Clamping pads GN 709.6 are also used in jig and fixture construction, for example for clamping workpieces, as movable bearing surface or as stop. The swivel-mounted ball compensates uneven and non-parallel contact surfaces by as much as 10°. It is also secured against further twisting.

The O-ring holds the ball in position and prevents dirt from penetrating, resulting in a long service life and constant mobility.

TECHNICAL INFORMATION

- Strength values of screws (see page A20)
- Plastic characteristics (see page A2)
- Elastomer characteristics (see page A32)

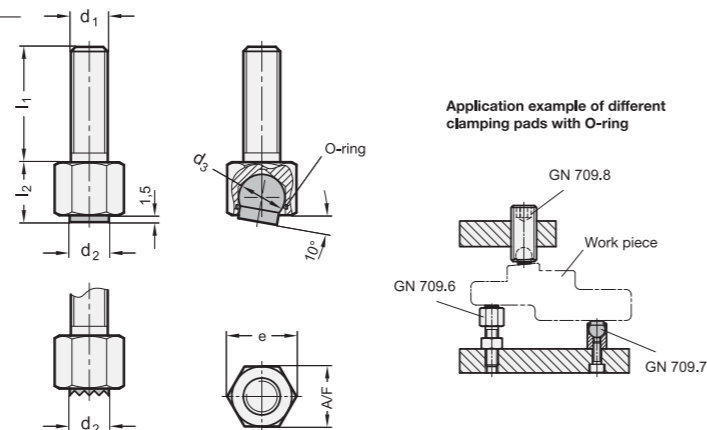

GN 709.6

Description	d1	l1	d2	d3	l2	A/F	e	Static load max. in kN	⚖️
GN 709.6-M6-12-B	M 6	12	6	7	9.5	10	11.5	12	8
GN 709.6-M6-25-B	M 6	25	6	7	9.5	10	11.5	12	10
GN 709.6-M6-40-B	M 6	40	6	7	9.5	10	11.5	12	12
GN 709.6-M8-12-B	M 8	12	8.5	10	13	13	15	20	16
GN 709.6-M8-25-B	M 8	25	8.5	10	13	13	15	20	20
GN 709.6-M8-40-B	M 8	40	8.5	10	13	13	15	20	26
GN 709.6-M6-12-K	M 6	12	6	7	9.5	10	11.5	2	6
GN 709.6-M6-25-K	M 6	25	6	7	9.5	10	11.5	2	8
GN 709.6-M6-40-K	M 6	40	6	7	9.5	10	11.5	2	12
GN 709.6-M8-12-K	M 8	12	8.5	10	13	13	15	4	13
GN 709.6-M8-25-K	M 8	25	8.5	10	13	13	15	4	16
GN 709.6-M8-40-K	M 8	40	8.5	10	13	13	15	4	21
GN 709.6-M6-12-R	M 6	12	6	7	9.5	10	11.5	6	7
GN 709.6-M6-25-R	M 6	25	6	7	9.5	10	11.5	6	9
GN 709.6-M6-40-R	M 6	40	6	7	9.5	10	11.5	6	12
GN 709.6-M8-12-R	M 8	12	8.5	10	13	13	15	9	16
GN 709.6-M8-25-R	M 8	25	8.5	10	13	13	15	9	20
GN 709.6-M8-40-R	M 8	40	8.5	10	13	13	15	9	24

Clamping pads with female thread

SPECIFICATION

Types

- Type **B**: Ball steel, smooth contact face
- Type **R**: Ball steel, serrated contact face
- Type **K**: Ball plastic, smooth contact face

Steel

- tempered
- Tensile strength class 10.9

Ball

- Type B and R:
Steel hardened (54+2 HRC)
- Type K:
Plastic (Polyacetal POM)
- O-Ring
Rubber NBR (Perbunan)

INFORMATION

Clamping pads GN 709.7 are also used in jig and fixture construction, for example for clamping workpieces, as movable bearing surface or as stop. The swivel-mounted ball compensates uneven and non-parallel contact surfaces by as much as 10°. It is also secured against further twisting.

The O-ring holds the ball in position and prevents dirt from penetrating, resulting in a long service life and constant mobility.

TECHNICAL INFORMATION

- Strength values of screws (see page A20)
- Plastic characteristics (see page A2)
- Elastomer characteristics (see page A32)

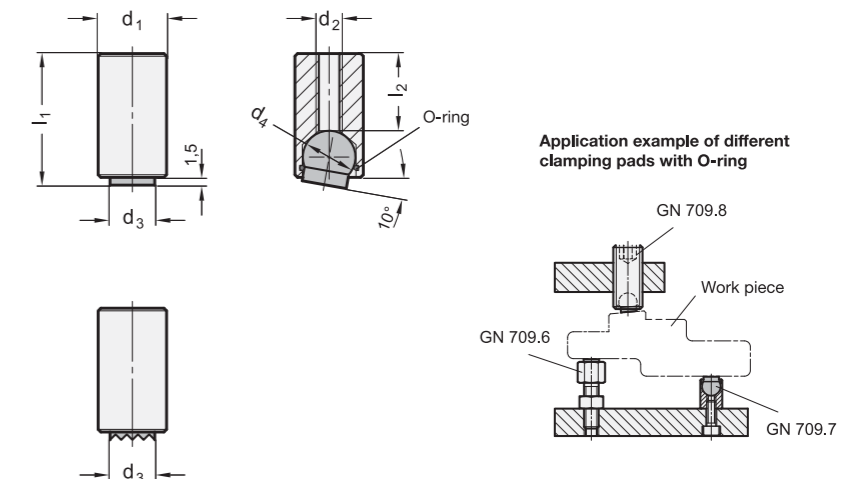

GN 709.7

Description	d1 h9	l1 ±0.13	d2	d3	d4	l2	Static load max. in kN	⚖️
GN 709.7-10-12-B	10	12	M 4	6	7	5.6	12	7
GN 709.7-10-25-B	10	25	M 4	6	7	18.6	12	14
GN 709.7-13-16-B	13	16	M 5	8.5	10	7.2	20	15
GN 709.7-13-25-B	13	25	M 5	8.5	10	16.2	20	24
GN 709.7-10-12-K	10	12	M 4	6	7	5.6	2	5
GN 709.7-10-25-K	10	25	M 4	6	7	18.6	2	12
GN 709.7-13-16-K	13	16	M 5	8.5	10	7.2	4	12
GN 709.7-13-25-K	13	25	M 5	8.5	10	16.2	4	20
GN 709.7-10-12-R	10	12	M 4	6	7	5.6	6	7
GN 709.7-10-25-R	10	25	M 4	6	7	18.6	6	14
GN 709.7-13-16-R	13	16	M 5	8.5	10	7.2	9	15
GN 709.7-13-25-R	13	25	M 5	8.5	10	16.2	9	23

Clamping pads

adjustable

SPECIFICATION

Types

- Type **B**: Ball steel, smooth contact face
- Type **R**: Ball steel, serrated contact face
- Type **K**: Ball plastic, smooth contact face

Steel

- tempered
- Tensile strength class 10.9

Ball

- Type B and R:
Steel hardened (54+2 HRC)
- Type K:
Plastic (Polyacetal POM)

O-Ring

- Rubber NBR (Perbunan)

INFORMATION

Clamping pads GN 709.8 are also used in jig and fixture construction, for example for clamping workpieces, as movable bearing surface or as stop. The swivel-mounted ball compensates uneven and non-parallel contact surfaces by as much as 10°. It is also secured against further twisting.

The O-ring holds the ball in position and prevents dirt from penetrating, resulting in a long service life and constant mobility.

TECHNICAL INFORMATION

- Strength values of screws (see page A20)
- Plastic characteristics (see page A2)
- Elastomer characteristics (see page A32)

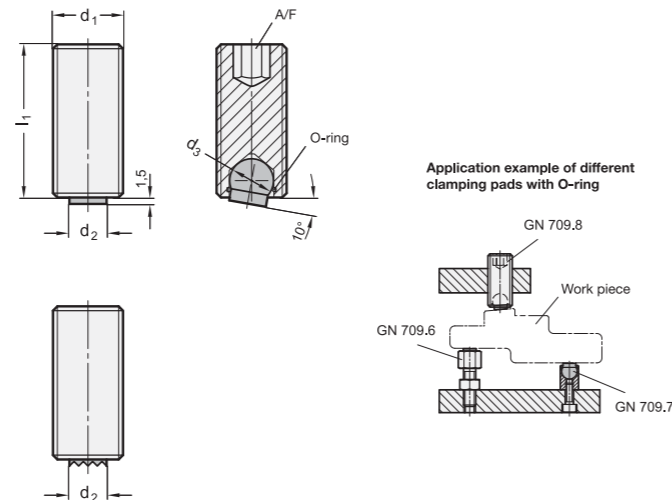

GN 709.8

Description	d1	l1 ±0.13	d2	d3	A/F	Static load max. in kN	⚖
GN 709.8-M12-25-B	M 12	25	6	7	6	12	15
GN 709.8-M12-35-B	M 12	35	6	7	6	12	22
GN 709.8-M12-50-B	M 12	50	6	7	6	12	32
GN 709.8-M16-25-B	M 16	25	8.5	10	8	20	27
GN 709.8-M16-35-B	M 16	35	8.5	10	8	20	40
GN 709.8-M16-50-B	M 16	50	8.5	10	8	20	60
GN 709.8-M12-25-K	M 12	25	6	7	6	2	13
GN 709.8-M12-35-K	M 12	35	6	7	6	2	20
GN 709.8-M12-50-K	M 12	50	6	7	6	2	31
GN 709.8-M16-25-K	M 16	25	8.5	10	8	4	23
GN 709.8-M16-35-K	M 16	35	8.5	10	8	4	36
GN 709.8-M16-50-K	M 16	50	8.5	10	8	4	56
GN 709.8-M12-25-R	M 12	25	6	7	6	6	15
GN 709.8-M12-35-R	M 12	35	6	7	6	6	22
GN 709.8-M12-50-R	M 12	50	6	7	6	6	32
GN 709.8-M16-25-R	M 16	25	8.5	10	8	9	26
GN 709.8-M16-35-R	M 16	35	8.5	10	8	9	36
GN 709.8-M16-50-R	M 16	50	8.5	10	8	9	59

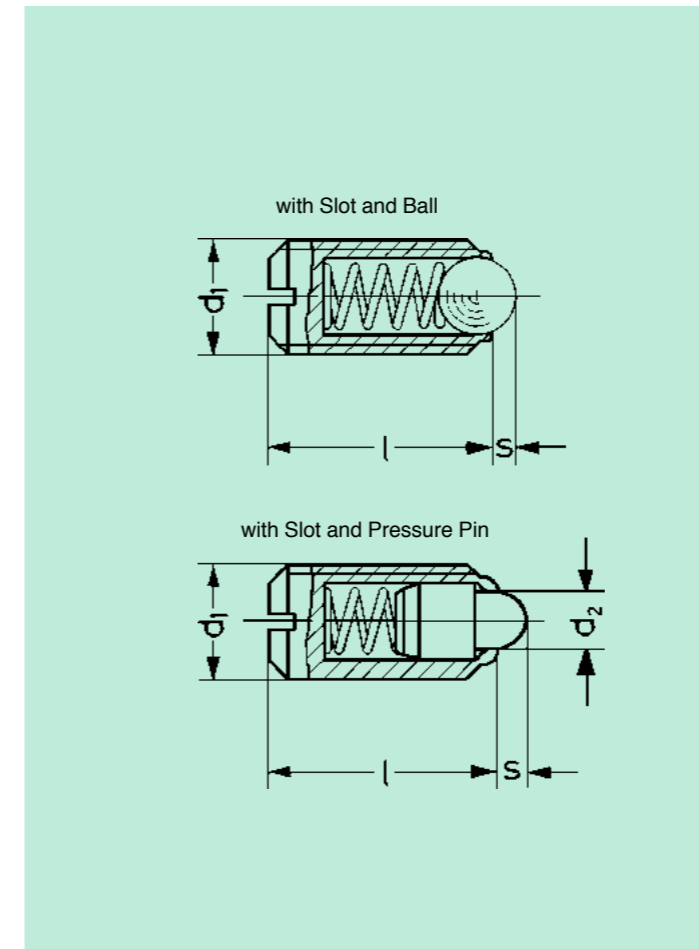

Spring Plungers

INOX



Spring Plungers are used for locking and positioning. They also serve for push-on and push-off operations. They are used for example in fixture and tool shops.

Model Spring Plungers with Slot and Ball:

Type K: Steel, black oxide finished. Ball hardened and blank.

Type KN: Stainless steel, material no. 1.4305, blank. Ball hardened and blank. Heat-resistance: 250°-350° C.

Model Spring Plungers with Slot and Pressure Pin:

Type K: Steel, black oxide finished. Pressure pin hardened.

Spring Plungers with Slot and Ball

Order No.	Order No.	d1	Ball Ø mm	l mm	s mm	Initial Pressure approx. N	Final Pressure approx. N	Weight approx. g
Type K	Type KN							
40 103	40 203	M 3	1,5	7	0,5	2	3	0,2
40 104	40 204	M 4	2,5	9	0,8	6	12	0,6
40 105	40 205	M 5	3	12	0,9	7	13	0,9
40 106	40 206	M 6	3,5	14	1	9	15	1,5
40 108	40 208	M 8	5	16	1,5	20	35	3,5
40 110	40 210	M 10	6	19	2	25	45	7
40 112	40 212	M 12	8	22	2,5	35	60	10
40 116	40 216	M 16	10	24	3,5	65	110	24
40 120	40 220	M 20	12	30	4,5	90	140	43
40 124	40 224	M 24	15	34	5,5	125	180	70

Spring Plungers with Slot and Pressure Pin

Order No.	d1	d2 mm	l mm	s mm	Initial Pressure approx. N	Final Pressure approx. N
Type K						
43 104	M 4	1,8	9	1,5	6	16
43 105	M 5	2,4	12	2	6	17
43 106	M 6	2,7	14	2	7	18
43 108	M 8	4	16	2	20	35
43 110	M 10	4,5	19	2,5	20	45
43 112	M 12	6	22	3,5	25	60
43 116	M 16	8,5	24	4,5	50	95
43 120	M 20	10	30	6,5	80	140

Spring Plungers

INOX



Model with Hexagon Socket and Pressure Pin:
Capable of being assembled from both sides.

Type A: Insert from steel, black oxide finished.
Pressure pin of steel, hardened.

Type D: Insert from steel. Pressure pin from plastic (delrin).

Type AN: Complete from stainless steel available on request.

Model with Smooth Sleeve:

Type K: Sleeve from plastic (delrin), ball from stainless steel.

Type N: Sleeve and ball from stainless steel.

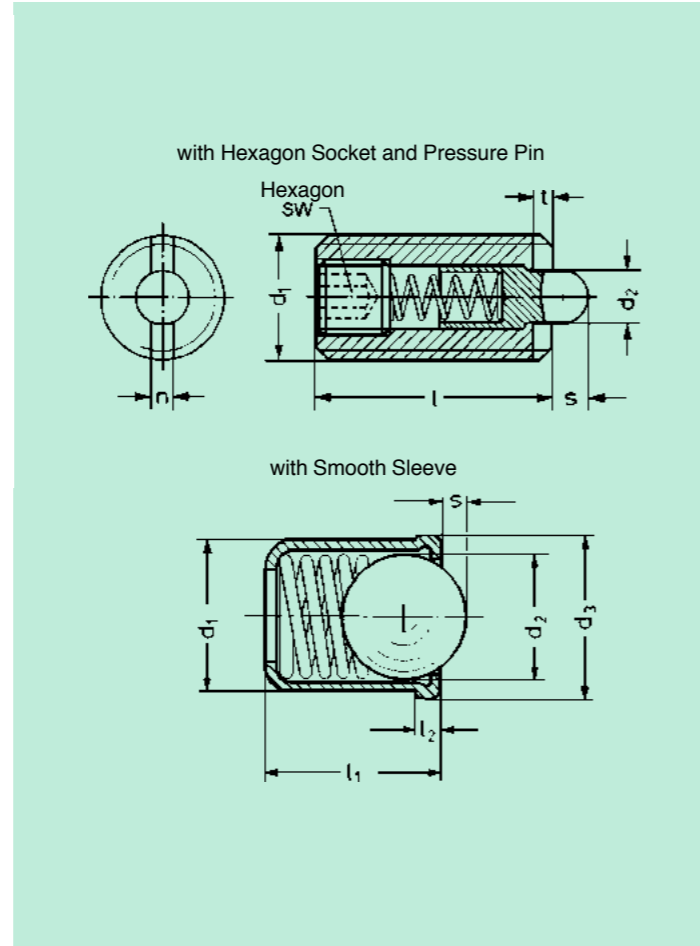

Spring Plungers with Hexagon Socket and Pressure Pin

Order No.	Order No.	d ₁	d ₂	l	s	n	t	sw	Initial Pressure approx. N	Final Pressure approx. N	Weight approx. g
Type A	Type D		mm	mm	mm	mm	mm	mm			
41 104	41 204	M 4	1,5	15	1,5	0,6	0,6	1,3	5	15	0,8
41 105	41 205	M 5	2,4	18	2,3	1,2	0,8	1,5	7	20	1,3
41 106	41 206	M 6	2,7	20	2,5	1,3	0,9	2	7	20	2,5
41 108	41 208	M 8	3,5	22	3	1,5	1,4	2,5	9	35	6
41 110	41 210	M 10	4	22	3	1,5	1,4	3	9	35	9
41 112	41 212	M 12	6	28	4	2,7	2	4	15	55	16
41 116	41 216	M 16	7,5	32	5	3,2	2,5	5	45	100	35
41 120		M 20	10	40	7	3,7	3	6	70	140	65
41 124		M 24	12	52	10	3,7	3	8	80	180	120

Spring Plungers with Smooth Sleeve

Order No.	d ₁	Initial Pressure approx. N	Final Pressure approx. N	Weight approx. g	Order No.	d ₁	Initial Pressure approx. N	Final Pressure approx. N	Weight approx. g	d ₂	d ₃	l ₁	l ₂	s
Type K	mm				Type N	mm				mm	mm	mm	mm	mm
42 204	4	3,5	7	0,17	42 104	4	2	5	0,3	3	4,6	5	1	0,9
42 205	5	5	9	0,35	42 105	5	4	7	0,6	4	5,6	6	1	1
42 206	6	8	14	0,68	42 106	6	6	12	1,0	5	6,5	7	1	1,5
42 208	8	9	17	1,45	42 108	8	6	12	2,0	6,5	8,5	9	1	1,8

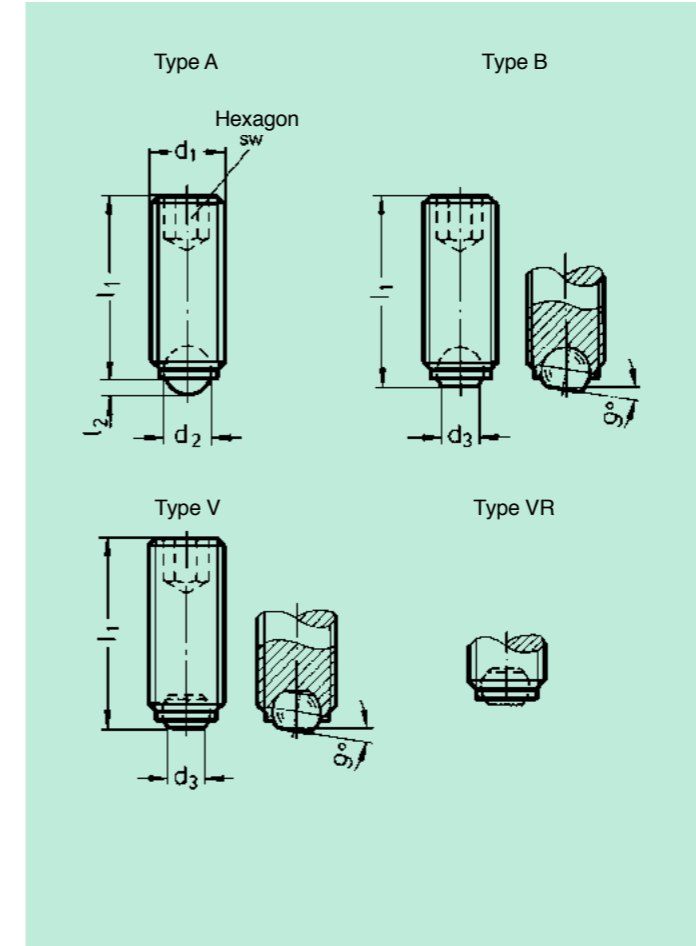

Ball Clamping Screws



Ball clamping screws with solid ball (Type A) are used in applications where a ball point contact is required.

The flat faced movable ball allows the clamping or supporting of non parallel surfaces.

The maximum rotating efficiency (Type V/VR) for the ball is only 9°, thereby safely adjusted, so that always tensioned with the surface.

Model: Steel 10.9 or 12.9, black oxide finished.
Ball hardened, blank.

Type A: solid ball

Type B: flat ball

Type V: flat ball with safety rotary

Type VR: flat ball with safety rotary, knurled

Ball clamping screws with head are available on request.

Ball Clamping Screws

Order No.	Order No.	Order No.	Order No.	Thread d ₁	Length of Screw l ₁ (mm)				d ₂	d ₃	l ₂	sw
Type A	Type B	Type V	Type VR					mm	mm	mm		
47 04 .. A				M 4	10	16		2,5		0,4	2	
47 05 .. A				M 5	12	20		3		0,6	2,5	
47 06 .. A	47 06 .. B	47 06 .. V	47 06 .. VR	M 6	10	20	25	4	3,2	0,8	3	
47 08 .. A	47 08 .. B	47 08 .. V	47 08 .. VR	M 8	10	20	30	5,5	4,5	1,2	4	
47 10 .. A	47 10 .. B	47 10 .. V	47 10 .. VR	M 10	12	20	25	7	6	1,7	5	
47 12 .. A	47 12 .. B	47 12 .. V	47 12 .. VR	M 12	16	30	40	8,5	7,2	2	6	
47 16 .. A	47 16 .. B	47 16 .. V	47 16 .. VR	M 16	20			12	10,7	3,3	8	

..Please indicate here the desired length, e.g. 010 for l₁ = 10 mm

Ball Clamping Screws

from Stainless Steel

INOX



Ball clamping screws with solid ball (Type AN) are used in applications where a ball point contact is required.

The flat faced movable ball allows the clamping or supporting of non-parallel surfaces.

The maximum rotating efficiency (Type VN/VRN) for the ball is only 9°, thereby safely adjusted, so that always tensioned with the surface.

Model: stainless steel 1.4301/1.4006.
Ball hardened, blank.

Type AN: solid ball

Type BN: flat ball

Type VN: flat ball with safety rotary

Type VRN: flat ball with safety rotary, knurled

Ball clamping screws with head are available on request.

Ball Clamping Screws - Stainless Steel

Order No.	Order No.	Order No.	Order No.	Thread	Length of Screw l ₁ (mm)				d ₂	d ₃	l ₂	sw	
Type AN	Type BN	Type VN	Type VRN	d ₁					mm	mm	mm		
47 04 .. AN E0A				M 4	10	16			2,5	0,4	2		
47 05 .. AN E0A				M 5	12	20			3	0,6	2,5		
47 06 .. AN E0A	47 06 .. BN E0A	47 06 .. VN E0A	47 06 .. VRN E0A	M 6	10	20 25			4	3,2	0,8	3	
47 08 .. AN E0A	47 08 .. BN E0A	47 08 .. VN E0A	47 08 .. VRN E0A	M 8	10	20	30		5,5	4,5	1,2	4	
47 10 .. AN E0A	47 10 .. BN E0A	47 10 .. VN E0A	47 10 .. VRN E0A	M 10	12	20 25			7	6	1,7	5	
47 12 .. AN E0A	47 12 .. BN E0A	47 12 .. VN E0A	47 12 .. VRN E0A	M 12		16	30 40		8,5	7,2	2	6	
47 16 .. AN E0A	47 16 .. BN E0A	47 16 .. VN E0A	47 16 .. VRN E0A	M 16		20			50	12	10	3,3	8

..Please indicate here the desired length, e.g. 010 for l₁ = 10 mm

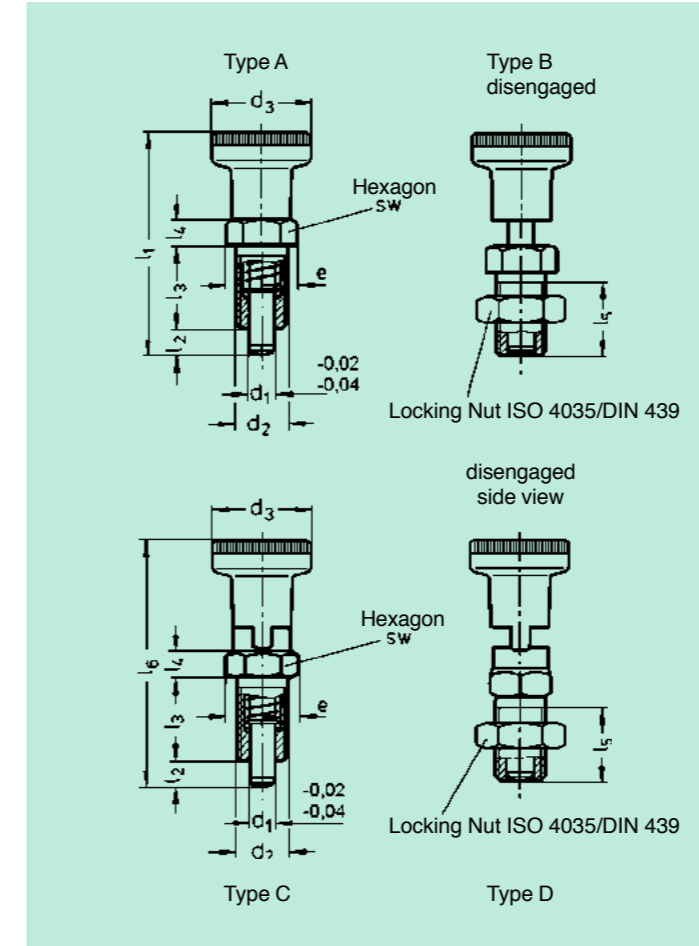
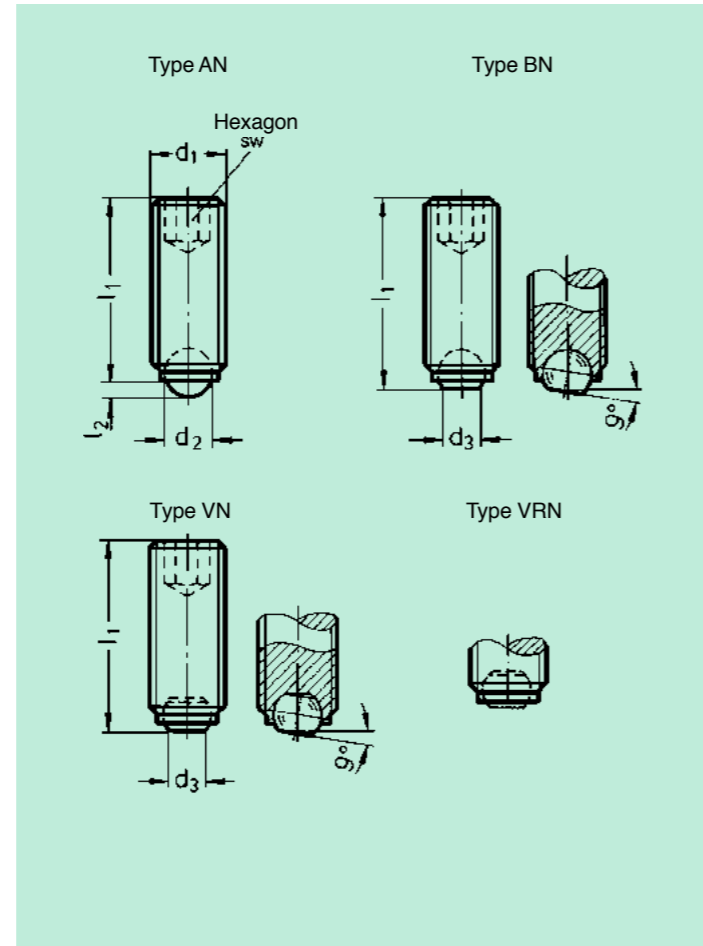

Fixing Bolts

from Steel resp. Stainless Steel

INOX



Model Steel: Knob from polyamide black matt. Steel parts stability class 5.8, black oxide finish. Locking bolt hardened and ground.

Model Stainless Steel: Knob from polyamide black matt. Steel parts from stainless steel, Material No. 1.4305. Locking bolt ground and nitrated.

Type A: without Fixing Slot, without Locking Nut

Type B: without Fixing Slot, with Locking Nut

Type C: with Fixing Slot, without Locking Nut

Type D: with Fixing Slot, with Locking Nut

Note for Zimmermann Fixing Bolts:

Fixing bolts are used when a change of resting position by axial loads has to be avoided. Another resting position only can be choiced if bolt has been pressed out manually. If fixing pin has to be locked out longer time and unintentional resting has to be avoided, please use Type C resp. Type D.

Zimmermann Fixing Bolts - Steel

Order No.	Order No.	Order No.	Order No.	Size	d ₂	d ₃	e	l ₁	l ₂	l ₃	l ₄	l ₅	l ₆	sw
Type A	Type B	Type C	Type D	d ₁ mm	mm	mm	mm	mm	min. mm	mm	mm	mm	min. mm	mm
30 05 A	30 05 B	30 05 C	30 05 D	5	M 10 x 1	21	13,8	45	5	17	5	15	51	12
30 06 A	30 06 B	30 06 C	30 06 D	6	M 12 x 1,5	25	16,2	54,5	6	20	6	17	61	14
30 08 A	30 08 B	30 08 C	30 08 D	8	M 16 x 1,5	31	21,9	69	8	26	8	23	75,5	19
30 10 A	30 10 B	30 10 C	30 10 D	10	M 20 x 1,5	31	25,4	80	10	33	10	30	91	22

Zimmermann Fixing Bolts - Stainless Steel

Order No.	Order No.	Order No.	Order No.	Size	d ₂	d ₃	e	l ₁	l ₂	l ₃	l ₄	l ₅	l ₆	sw
Type A	Type B	Type C	Type D	d ₁ mm	mm	mm	mm	mm	min. mm	mm	mm	mm	min. mm	mm
30 05 A E0A	30 05 B E0A	30 05 C E0A	30 05 D E0A	5	M 10 x 1	21	13,8	45	5	17	5	15	51	12
30 06 A E0A	30 06 B E0A	30 06 C E0A	30 06 D E0A	6	M 12 x 1,5	25	16,2	54,5	6	20	6	17	61	14
30 08 A E0A	30 08 B E0A	30 08 C E0A	30 08 D E0A	8	M 16 x 1,5	31	21,9	69	8	26	8	23	75,5	19
30 10 A E0A	30 10 B E0A			10	M 20 x 1,5	31	25,4	80	10	33	10	30		22

Fixing Bolts

without Collar
Steel/ Stainless Steel

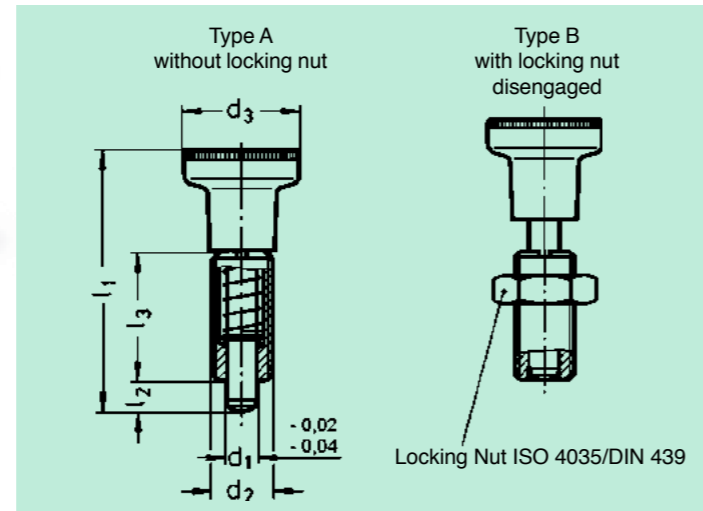

56

INOX

Fixing bolts without collar are a low cost alternative.

Model Steel: Knob from polyamide black matt. Steel parts stability class 5.8, black oxide finished. Locking bolt hardened and ground.

Model Stainless Steel: Steel parts from stainless steel, material no. 1.4305. Locking bolt ground and nitrated.

A special screwdriver is available. Two slots are provided in the upper end of the body which are accessible with the knob in its retracted position.

Fixing Bolts without Collar - Steel resp. Stainless Steel

Order No. Steel Type A	Order No. Steel Type B	Order No. Stainless Steel Type A	Order No. Stainless Steel Type B	Size d ₁ mm	d ₂ mm	d ₃ mm	l ₁ mm	l ₂ min. mm	l ₃ mm	Order No. Screw Driver
59 05 A	59 05 B	59 05 A E0A	59 05 B E0A	5	M 10 x 1	21	44	5	22	59 05 S
59 06 A	59 06 B	59 06 A E0A	59 06 B E0A	6	M 12 x 1,5	25	53	6	26	59 06 S
59 08 A	59 08 B	59 08 A E0A	59 08 B E0A	8	M 16 x 1,5	31	67	8	34	59 08 S
59 10 A	59 10 B	59 10 A E0A	59 10 B E0A	10	M 20 x 1,5	31	78	10	43	59 10 S

Fixing Bolts

without Thread

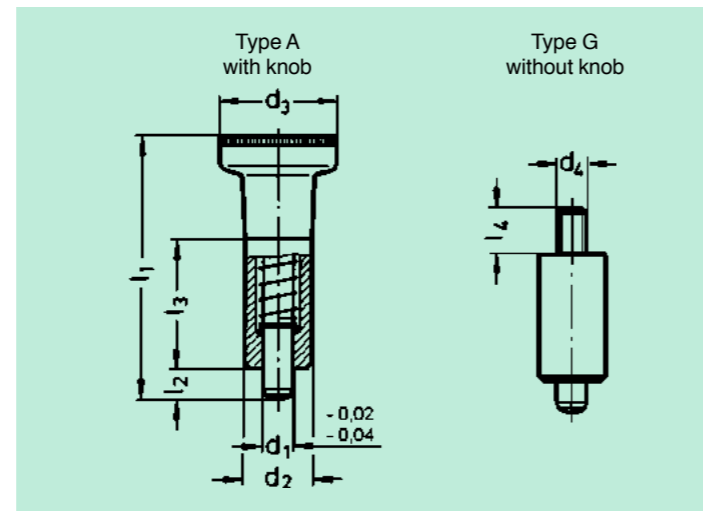

Fixing bolts without thread are for applications where welding or resin bonding is favoured. Type G with threaded bolt end are for applications where a special knob to customers own design is required or for such cases where the spindle is linked directly to an operating mechanism.

Model: Knob from polyamide black matt. Steel parts black oxide finished, weldable. Locking bolt hardened and ground.

Fixing Bolts without Thread

Order No. Type A	Order No. Type G	Size d ₁ mm	d ₂ h ₉ mm	d ₃ mm	d ₄ mm	l ₁ mm	l ₂ min. mm	l ₃ mm	l ₄ mm
58 05 A	58 05 G	5	12	21	M 5	44	5	22	6
58 06 A	58 06 G	6	14	25	M 6	53	6	26	10
58 08 A	58 08 G	8	18	31	M 8	67	8	34	12

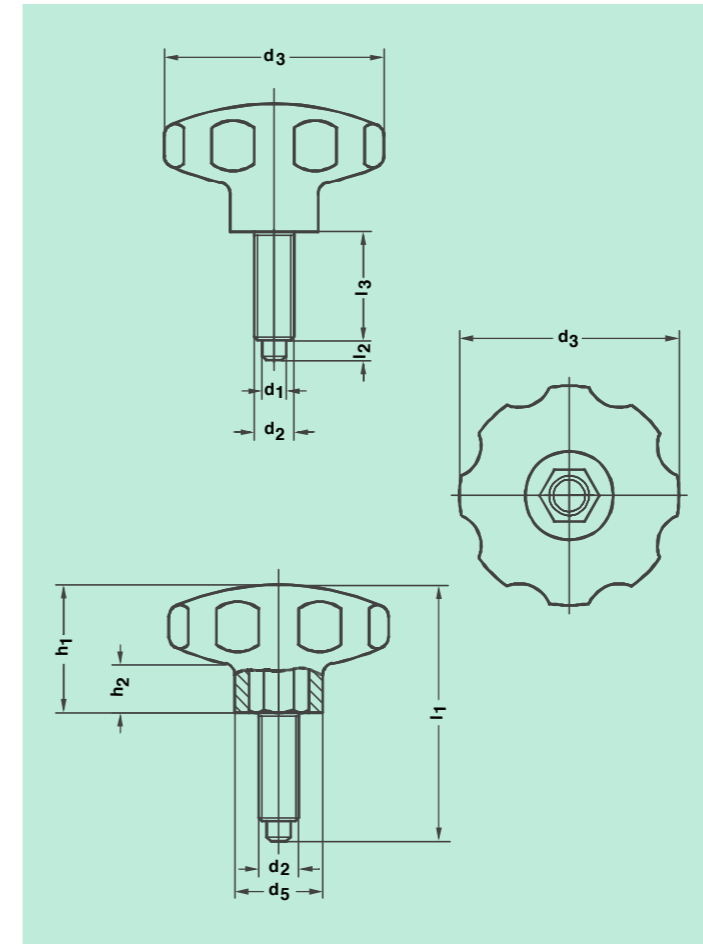

Fixing and Clamping Knobs



Fixing and Clamping Knobs allow for quick and precise positioning, securing and clamping of adjusting elements.

Especially efficient for moving telescopes or similar applications.

Model: Body from polyamide, black. Screw from steel, zinc-plated.

Fixing- and Clamping Knobs

Order No.	External Thread d ₂	Size d ₃ mm	d ₁ mm	d ₅ mm	l ₁ mm	l ₂ mm	l ₃ mm	h ₁ mm	h ₂ mm
49 025 08 04	M8 x 1	25	4	12	35	5	10	20	8
49 025 10 05	M10 x 1	25	5	12	38	5	13	20	8
49 025 12 06	M12 x 1,5	25	6	12	43	6	17	20	8
49 035 10 05	M10 x 1	35	5	17	47	5	15	27	10
49 055 10 05	M10 x 1	55	5	25	52	5	15	32	12
49 055 12 06	M12 x 1,5	55	6	25	58	6	20	32	12
49 055 16 08	M16 x 1,5	55	8	25	68	9	27	32	12
49 065 16 08	M16 x 1,5	65	8	30	70	8	22	40	14

Indexing Bolts

INOX

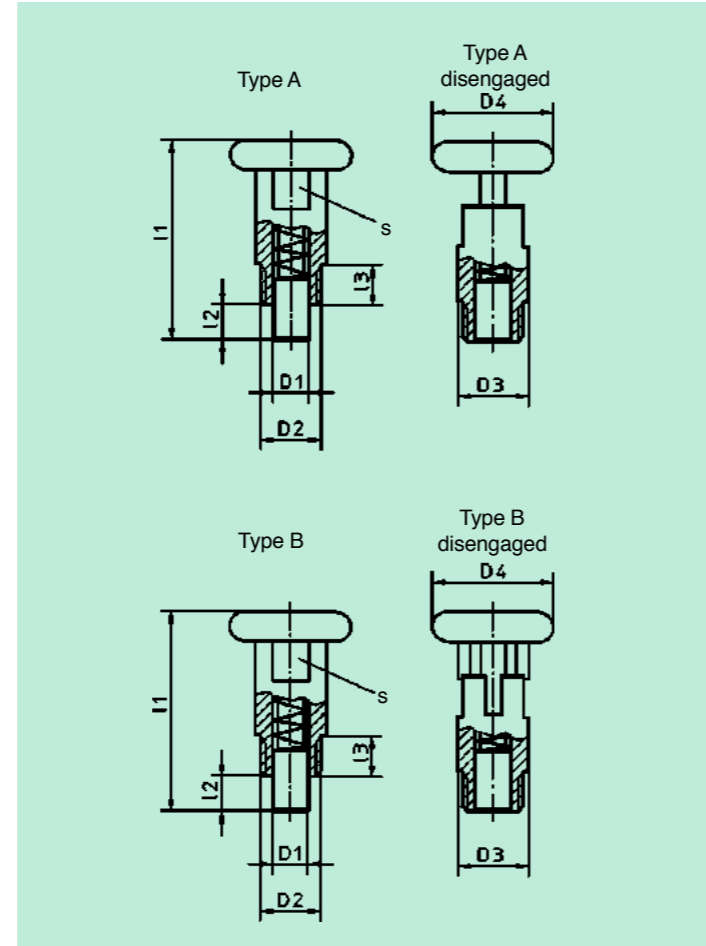

Indexing Bolts have the same application as Fixing Bolts. However they are a low-cost alternative to them.

Model: Steel zinc plated, resp. stainless steel.

Type A: without Fixing Slot.

Type B: with Fixing Slot.

Indexing Bolts - Steel

Order No. Type A	Order No. Type B	Size d ₄ mm	d ₁ mm	d ₂ mm	d ₃ mm	l ₁ mm	l ₂ mm	l ₃ mm	Type A s	Type B s
77 06 A	77 06 B	18	M10x1	6	11,4	31	7	4	10	10
77 07 A	77 07 B	24	M12x1,75	7	14,0	40	7	8	12	12

Indexing Bolts - Stainless Steel

Order No. Type A	Order No. Type B	Size d ₄ mm	d ₁ mm	d ₂ mm	d ₃ mm	l ₁ mm	l ₂ mm	l ₃ mm	Type A s	Type B s
77 06 A E0A	77 06 B E0A	18	M10x1	6	11,4	31	7	4	10	10
77 07 A E0A	77 07 B E0A	24	M12x1,75	7	14,0	40	7	8	12	12