

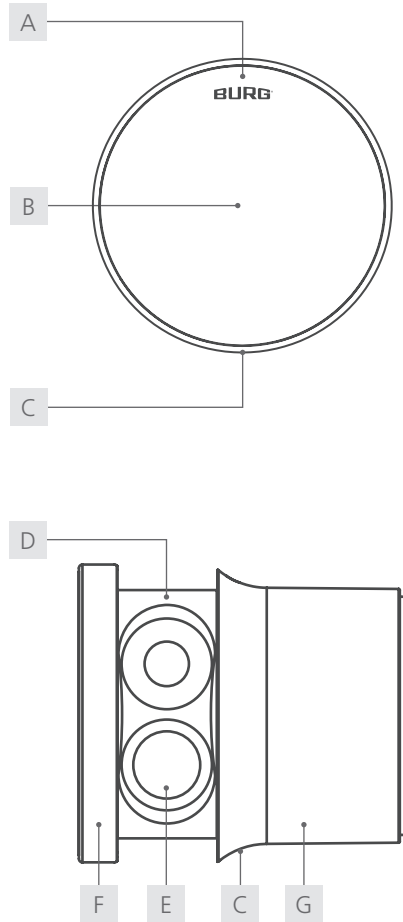

Flexo.RFID

Operating Manual

Flexo.RFID



- | | |
|-----------------------|------------------------------|
| A LED | B RFID antenna |
| C closure hole | D battery compartment |
| E battery | F knob |
| G housing | |

Content

Introduction.....	2
General.....	2
Technical data.....	3
Scope of delivery.....	3
Optional accessories.....	3
Default settings.....	3
Features.....	3
Product dimesions.....	3
Functional description.....	4
Assembly flush fit.....	5
Assembly retro fit.....	6
Configuration.....	7
Operation.....	7
Battery replacement.....	8
Disposal and battery note.....	8

Introduction

The **Flexo.RFID** (Radio Frequency Identification) sets a new standard. It was developed for the leading RFID standards (MIFARE® Classic 1K and MIFARE® Desfire EV II). Thanks to the three authorization levels (master, manager and user), the lock offers high flexibility in operation.

Like all locks in the Flexo range, the RFID variant allows both recessed installation (flush fit) and retrofitting (retro fit). Thanks to the possible one-, two- or three-point locking with latch function, it adapts conveniently to any installation situation.

Important: Please observe all warnings and read through the entire operating instructions before you begin with the configuration.

General

The latest version of this guide is available at:
www.burg.de

Factsheet

Front view



Back view



Technical Data

Dimension	Ø 50 mm
Battery	VARTA ¹ 1/2 AA (2x)
Locking cycles ¹	25,000
Working temperature	-20° C to 55° C rel. humidity: 10% - 85%
Mode	Multi User Mode, Private Mode
Material	Housing: plastic Cam: steel
Mounting dimension	16 mm x 19 mm
Lock attachment	M19 nut (1x)
Locking direction	Left (90°), door hinge: DIN right
Cam type	B
Max. door thickness	18 mm
RFID variants	MIFARE [®] Classic (read only), MIFARE [®] Desfire EV II (read only)
No. of Master Cards	max. 3
No. of manager cards	max. 2
No. of user cards	max. 10

Scope of Delivery

- 1x locking system
 - 1x cam fixing screw² M6 x 12 mm
 - 1x M19 nut
 - cam type B
- for single packaging:
- 1x length 53 mm, without crank (1-36 RIH-501 G)
 - 1x length 40 mm, crank 3 mm (1-36 RIH-514 K)
 - 1x length 40 mm, cranking 6 mm (1-36 RIH-515 K)
- for industry packaging: order related

¹ The lock is approved for VARTA brand batteries. The use of other batteries may result in a reduced number of possible locking cycles.

² The use of a screw with a different length may cause damage to the lock.

Optional Accessories

- Master Card
- anti-twist protection (W-MSZ-01)
- function card „mode change“
- function card „reset“
- opening pin
- Flexo.Ring + fixing nut

Default Settings

Mode	Private Mode
------	--------------

Features

- ergonomic handling and high-quality design
- external battery access and battery replacement
- RFID standards: MIFARE[®] Classic / MIFARE[®] Desfire EV II
- integrated occupied identification for MIFARE[®] Classic
- easy to retrofit, e.g. for replacement of mechanical locks
- adjustable cam (in 90° steps)

Product Dimensions

Front view

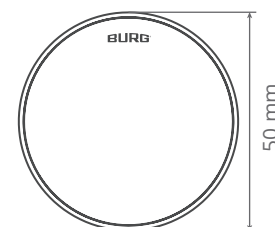

Side view

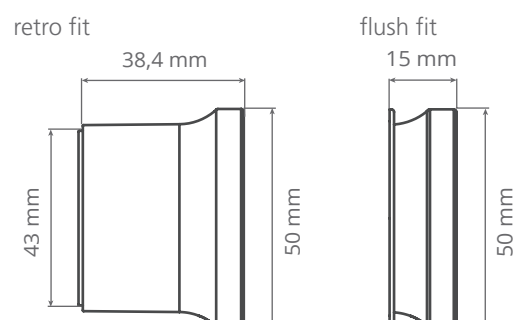

Functional Description

Mode: Fixed Assigned Authorization (Private Mode)

In this mode, a transponder medium is pre-set with which the lock can be operated. This mode is suitable for user groups where user rights do not have to change permanently, e.g. in an office cabinet. The lock can be unlocked with the stored transponder medium. Transponder media that are not stored are rejected by the lock. To unlock, the transponder medium is held centrally in front of the lock. To lock, the knob is turned back (counterclockwise) until the lock snaps in.

Mode: Multi User Authorization (Multi User Mode)

This mode is suitable for constantly changing users who only use the compartment temporarily or once, e.g. in a sports facility. Transponder media are valid for a single locking process and are deleted by the lock when the compartment is reopened so that a new transponder medium can be used. The locking bolt remains open until a new transponder medium locks the lock again. Before locking, the door must be closed and the knob turned counterclockwise. To lock, the transponder medium is held centrally in front of the lock. The LED starts to flash. The lock can only be unlocked with the same transponder medium.

Occupied Identification

The lock is in the Multi User Mode described above. However, the transponder used for locking is assigned a occupied identification so that it can not lock any another lock. The occupied identification is canceled during the opening process.

Note: Occupied identification is only possible with MIFARE® Classic transponders.

Master Card

The Master Card can open the lock independently of the set mode (emergency opening). In Multi User Mode, the transponder medium used for locking is deleted from the lock. The Master Card authorizes to assign and delete transponder media in private mode, as well as to delete all other assigned cards.

Manager Card

The Manager Card can open the lock independently of the set mode (emergency opening).

Mode Card

The mode is changed with the Mode Card. Hold the Mode Card centrally in front of the lock. The mode changes automatically.

Reset Card

With the Reset Card all cards (Master Cards, Manager Cards and User Cards) are deleted. The reset card can be used only in the open state.

LED Locking Indication

When the lock is locked, the green LED flashes briefly every three seconds.

Battery Warning

If the battery voltage falls below a certain level, three successive descending beeps sound when a transponder is held in front of the lock. If the voltage falls into the critical range, the lock can no longer be operated.

Assembly Flush Fit

- 1 Prepare the installation hole on the door front according to the installation dimensions described below.

Note: If you require a template (step file) for milling, punching or laser cutting, please contact your BURG representative.



- 2 From the front, insert the Flexo.Ring into the installation hole on the outside of the door and hold it in this position. Check whether the Flexo.ring is fully seated on the outside of the door. Make sure that the mounting hole on the inside is in the correct position. Screw the fastening nut to the Flexo.ring from behind. Tighten the nut hand-tight.



- 3 Insert the lock body from the outside of the door into the opening of the Flexo.Ring. Make sure that the BURG logo on the front of the knob is at the top.

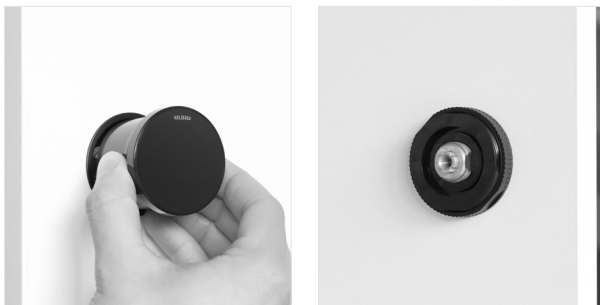

- 4 Place the fastening nut on the lock from behind. Tighten the nut with a socket wrench (SW22).



- 5 Place the latch and fasten it with the Torx screw (Torx 30) provided.

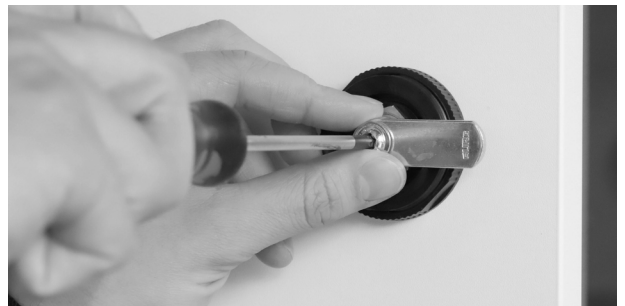

- 6 Then check whether the deadbolt gets sufficient hold on the strike plate or the rebate when closed. The latch should be able to be turned to its end position without pressure or resistance when the locking system is closed.



Mounting dimensions

The dimensions for the installation hole on the outside of the door applies to installation in fronts made of wood, HPL and steel.

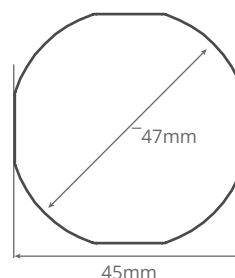

Note: The adjacent drawings drawings are not to scale and are not suitable as a template for milling. For a template (step file) please contact your contact person at BURG.

Assembly Retro Fit

- 1 Prepare the installation hole on the door front according to the installation dimensions described below. Note that an adapted two-stage recess may have to be milled for fronts made of wood and MDF. This recess is not required for metal fronts.

Note: If you require a template (step file) for milling, punching or laser cutting, please contact your BURG representative.

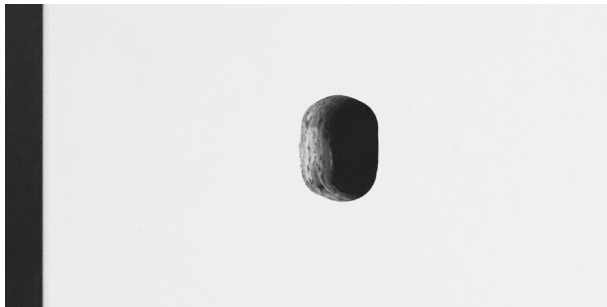

- 2 Insert the lock body into the installation hole from the outside of the door. Make sure that the BURG logo on the front of the knob is at the top.



- 3 Place the fastening nut on the lock from behind. Tighten the nut with a socket wrench (SW22).

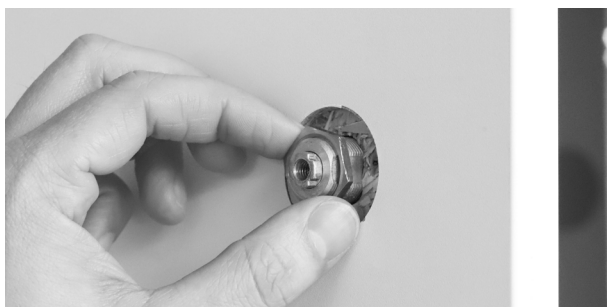

- 4 Place the latch and fasten it with the Torx screw (Torx 30) provided.



- 5 Then check whether the deadbolt gets sufficient hold on the strike plate or the rebate when closed. The latch should be able to be turned to its end position without pressure or resistance when the locking system is closed.

Note: Closing can be optimally adjusted by means of an adaptable striking plate. For more information, please get in touch with your contact at BURG.



Mounting dimensions

The dimensions for the installation hole on the outside of the door applies to installation in fronts made of wood, HPL and steel.

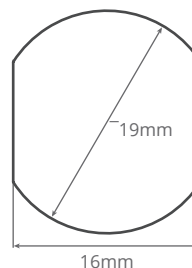

Note: The adjacent drawings are not to scale and are not suitable as a template for milling. For a template (step file), please contact your contact person at BURG.

Configuration

Observe the following notes before you start the configuration:

- The first card held in front of the lock during start-up is stored as the Master Card.

1 Assign Cards

a) Master Card

1. Insert batteries into the lock. (p. 8, „Battery Replacement“).
2. Hold the Master Card to be assigned centrally in front of the knob.
3. A beep confirms the successful process.

b) Further Master Cards

1. Hold the Master Card two times centrally in front of the knob. The green LED starts flashing.
2. Hold the Master Card to be assigned centrally in front of the knob.
3. A beep confirms the successful process.
4. Wait until the LED stops flashing.

Note: max. 3 Master Cards can be assigned.

c) Manager card

1. Hold the Master Card four times centrally in front of the knob. The green LED starts flashing.
2. Hold the manager card to be assigned centrally in front of the knob.
3. A beep confirms the successful process.
4. Wait until the LED stops flashing.

Note: max. 2 manager cards can be assigned.

d) User card (Privat-Modus)

1. Hold the Master Card three times centrally in front of the knob. The green LED starts flashing.
2. Hold the user card to be assigned centrally in front of the knob.
3. A beep confirms the successful process.
4. Wait until the LED stops flashing.

Note: max. 10 user cards can be assigned.

2 Delete cards (via function card „reset“)

1. Unlock the lock.
2. Hold the reset card centrally in front of the knob.
3. Two beeps and twice flashing of the green LED confirm the successful process.

Note: This operation deletes all cards from the lock. Cards can not be deleted individually. The set mode remains active.

3 Set the mode (via function card „mode change“)

1. Hold the Master Card centrally in front of the knob.
2. Hold the Mode Card centrally in front of the knob.
3. A long beep and the green LED for Private Mode or three long beeps and 3 times flashing of the green LED for Multi User Mode confirms the successful process.
4. Remove the mode card.

Note: During this process the manager cards and user cards are deleted.

Operation

1 Private Mode

a) Unlock

1. Hold the user card centrally in front of the knob. Wait for the longer beep and the green LED.
2. Turn the knob to the right (clockwise) within three seconds and pull the door.

Note: Unauthorized user cards are rejected by the lock with three consecutive beeps and 8 times flashing of the red LED.

b) Lock

The lock locks automatically within four seconds. The red LED flashes. To lock, turn the knob to the left (counterclockwise) until the lock snaps in.

2 Multi User Mode

a) Lock

1. Hold the user card centrally in front of the knob. Wait for the beep and the red LED.
2. To lock, turn the knob to the left (counterclockwise) until the lock snaps in.

b) Unlock

1. Hold the user card centrally in front of the knob. Wait for the longer beep and the green LED.
2. Turn the knob to the right (clockwise) within three seconds and pull the door.

Note: Unauthorized user cards are rejected by the lock with three consecutive beeps and 8 times flashing of the red LED.

Battery Replacement

1. Push the opening pin into the closure hole at the bottom of the lock. Move the pin slightly counterclockwise and pull the knob forward.
2. Open the battery cover and replace the batteries. Insert the new batteries according to the symbols (+ / -).
Note: The surface of the batteries must be free of residues and fingerprints, otherwise malfunctions may occur. If the surface is dirty, it must be cleaned with a dry cloth.
3. Close the battery cover, push the knob back onto the lock and turn the housing back until it locks into place.
Note: The lock is approved for VARTA brand batteries. The use of other batteries may result in a reduced number of possible locking cycles.

Disposal and Battery Note

EU Directive 2012/19/EU regulates the proper take-back, treatment and recycling of used electronic equipment.

Every consumer is required by law to dispose of batteries, accumulators or electrical and electronic equipment („waste equipment“) powered by batteries or accumulators separately from household waste, as they contain harmful substances and valuable resources. Disposal can be done at a collection or take-back point approved for this purpose, e.g. a local recycling center. Waste equipment, batteries or rechargeable batteries are accepted there free of charge and recycled in an environmentally friendly and resource-saving manner.

Waste equipment, used batteries or rechargeable batteries can also be returned to us. The return must be sufficiently stamped to the address below.

The following symbol on the waste electrical equipment, batteries or accumulators indicates that they must not be disposed of with household waste:



Caution when using batteries!

The battery may explode or release flammable gases if it is mishandled, destroyed, or the wrong type of battery is used. Do not recharge the battery, disassemble it, expose it to extremely high temperatures or throw it into a fire.

On batteries containing harmful substances, you will find indications in the form of abbreviations for the ingredients cadmium (Cd), mercury (Hg) and lead (Pb) in each case.

KACIN JOŽICA s.p. METALIKA

Račeva 8
Žiri | Slovenia
+ 386 68/176 519
info@metalika-kacin.com
www.metalika-kacin.com