

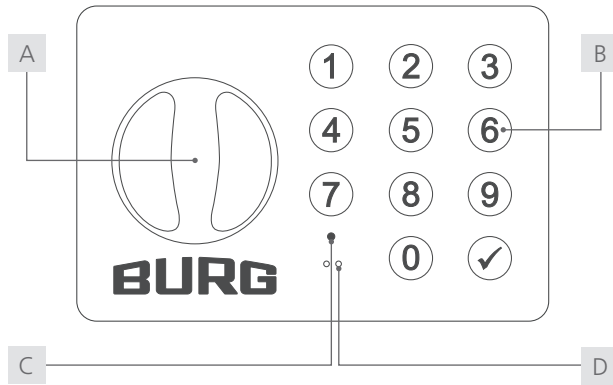

Combipad Operating Manual

Combipad



- A Turning knob
- B Touchpad buttons
- C Status LED
- D Emergency power socket

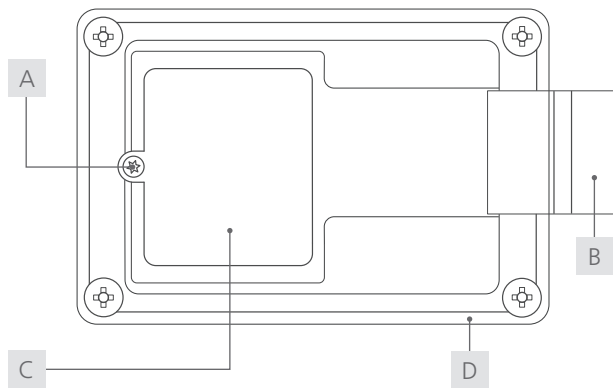

- A Battery compartment screw
- B Latch¹
- C Battery compartment
- D Fixing frame

Content

Introduction.....	2
General.....	2
Technical data.....	3
Default settings.....	3
Scope of delivery.....	3
Features.....	3
Dimensions.....	3 - 4
Functional description.....	4
Funktional description RTC.....	4
Assembly instructions.....	5
Configuration.....	6
Operation.....	6
Master Code entry.....	7
Batterie replacement.....	7
Disposal and battery note.....	7

General

The latest version of this guide is available at:
www.burg.de

Important notes:

- Please observe all important notes and read the entire operating manual before starting the configuration.

¹ With the version *Combipad Left*, the latch is located on the opposite side.
 Combipad | 04-25

Factsheet



Technical Parameters	
Dimensions	Combipad: 96 x 64 x 23 mm Fixing frame: 98 x 66 x 8,7 mm
Batteries	VARTA ¹ CR123A (2x)
Locking cycles	approx. 60,000
Working temperature	0° C to 40° C
No. of code combinations	999,999
Code length	4 or 6 digits
Mode	Multi User Mode, Private Mode
Material	Housing: zamak Keys: stainless steel Latch: zamak
Locking direction	Right, left
Lock attachment	Fixing frame
Max. door thickness	Without CNC milling: 8 mm With CNC milling: 19 mm
Break-off point	1800 N

Default Settings	
General code	Customer-specific
Master code	934716 (176394 ²)
Mode	Multi User Mode
Code length	4 digits
Locking	Manually
LED locking indication	On
Code confirmation	Off

Scope of Delivery

- 1x locking system
- 1x fixing frame
- 4x fixing screws
- 2x batteries (inserted)³

Features

- high-quality metal housing (Zamak) with stainless steel keys
- can be used in wooden and metal doors (indoors)
- latch system - door locks when pushed
- high battery life (60,000 locking cycles)
- LED locking indication
- simple configuration and programming
- ergonomic rotary knob and high-quality design
- integrated real-time clock (RTC)

Dimensions



¹ The lock is approved for VARTA brand batteries. The use of other batteries may result in a reduced number of possible locking cycles.

² applies to the variant *Combipad Left*
Combipad | 04-25

³ depending on contract and air freight restrictions

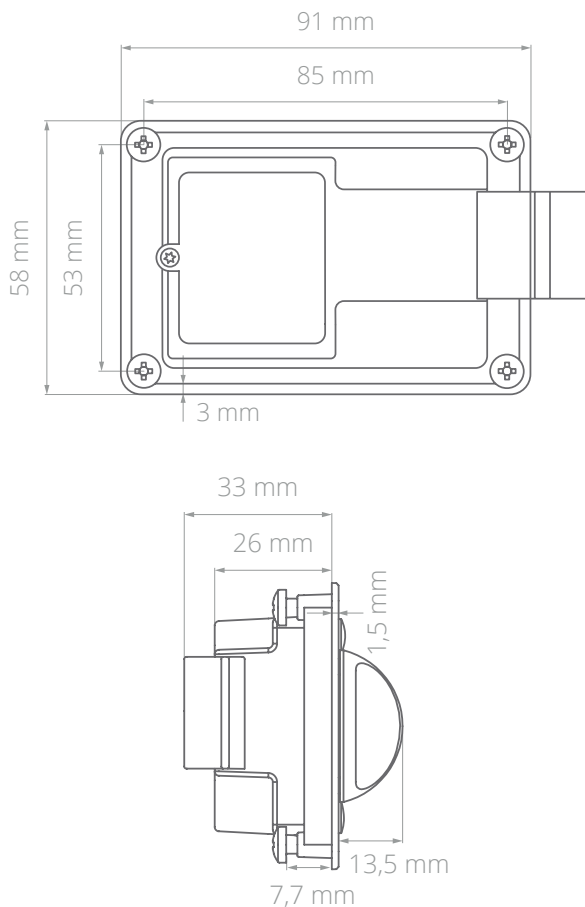

Functional Description

Mode: Fixed Assigned Authorization (Private Mode)

In this mode, a code is pre-set with which the lock can be operated. This mode is suitable for user groups where user rights do not have to change permanently, e.g. in an office cabinet. To close, the user enters a stored code. The lock is opened by entering this or another stored code. Up to 50 codes can be stored. A code that has not been stored is rejected by the lock.

Mode: Multi User Authorization (Multi User Mode)

This mode is suitable for constantly changing users who only use the compartment temporarily or once, e.g. in a sports facility. Codes are valid for a single locking process and are deleted by the lock when the compartment is reopened so that a new code can be used. The locking bolt remains open until a new code locks the lock again. Before locking, the door must be closed (slightly pressed). The user enters a code of choice (4 or 6 digits) to close. The green LED starts flashing. The lock is opened by entering the same code.

Code Confirmation

To lock the lock, the code must be entered twice. The lock only locks after the second entry. The second entry is made after the green LED flashes briefly. A simple code entry is sufficient to open the lock. This function can be turned on or off.

Master Code

The Master Code authorizes the programming of the lock. In addition, the Master Code can unlock the lock independently of the set mode (emergency opening) and terminate the block mode. In Multi User Mode, the code used for locking is deleted after the Master Code is entered.

Note: We recommend programming a private Master Code before putting the lock into operation.

LED Locking Indication

The lock indicates the locked state by flashing the red LED every second. This function can be turned on or off.

Automatic Locking (Private Mode)

The lock locks automatically after three seconds after unlocking. The door does not have to be closed for this. The latch function allows the door to be closed by pressing slightly even with the lock locked. This function can be turned on or off.

Battery Warning

If the battery capacity falls below a certain limit, the red LED lights up for three seconds after the code has been entered. If the critical level is reached, the lock can no longer be locked or can only be opened with the Master Code.

Note: We recommend changing the battery already after the first warning.

Block Mode

After three consecutive failed opening attempts, the lock locks for 45 seconds. During this period, no action is possible on the lock. The locking time is indicated by the red LED flashing every second. The locking mode can be cancelled by entering the Master Code.

Functional Description RTC

The Combipad RTC also has an integrated software real-time clock that can be used to program time-related functions. The functions and the defined times must be specified when ordering.

Automatic Locking / Unlocking at a certain time

The lock locks and unlocks automatically at a defined time. The times can be set separately for each day of the week. Programming is carried out by BURG.

Time Window Usage

The lock can only be operated within the individually defined time-of-use period. The lock cannot be operated outside this period. The times can be set separately for each day of the week. Programming is carried out by BURG.

Closure Duration

The closure duration defines the maximum period for which a lock may be locked from the time of locking. After expiry of the locking period, the lock opens automatically. Programming is carried out by BURG.

Assembly Instructions

- 1 Prepare the appropriate mounting hole on your furniture according to the installation drawing below. Note the adapted two-step recess for the fixing frame for fronts made of wood and HPL. This recess is not required for metal fronts or acrylic glass.

Note: If you need a template (step file) for CNC milling, punching or laser cutting, please contact your contact person at BURG.

- 2 Place the fixing frame in the mounting hole on the inside of the door and hold it in place.

- 3 Insert the lock body into the mounting hole from the outside of the door, bolt first. Make sure that the lock lies flush and tight on the outside of the door.

- 4 Screw the fixing frame to the lock body via the four screw holes (hand-tight, max. 2 Nm). Please note the required screw length. This depends on the door thickness in which the lock is installed.

- 5 Make sure that the bolt is sufficiently secured (approx. 5 mm) to a strike plate or rebate when closed. When closing the locking system, the bolt should fall easily into its end position without pressure.

Note: An adaptable strike plate can be used to set an optimal closing position. Please contact your contact person at BURG.



Mounting dimensions

The dimensions for the mounting hole on the outside of the door apply to installation in fronts made of wood, HPL and steel.

For fronts made of wood and HPL, a second recess is also required on the inside of the door. The dimensions of the milling correspond to the dimensions of the mounting frame.

Note: The drawings opposite are not to scale and are not suitable as a template for milling. Mounting dimensions and templates (STEP files) for milling, punching or lasering can be requested from BURG.

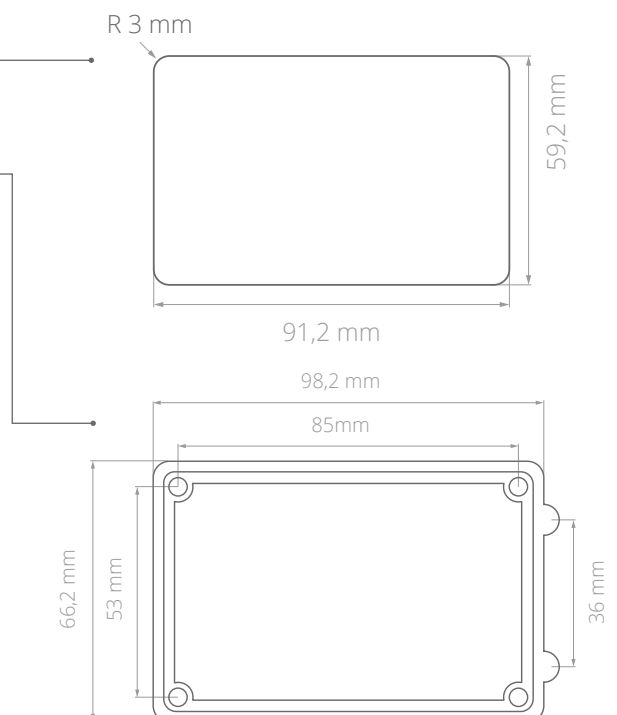

Configuration

Observe the following notes before you start the configuration:

- Each configuration step is started by pressing the hook key twice and the corresponding digit.
- For the configuration of the variant *Combipad Left*, only the digits written in brackets apply.
- Each configuration step is completed with the green LED flashing twice.
- The next configuration step can only be started after the the green LED flashes twice.
- If the red LED flashes 8 times in quick succession, the configuration step was not carried out correctly.

1 Mode Selection

a) Private Mode

Enter Master Code	✓✓ 1 (9) Master Code ✓
Set mode	✓✓ 5 (5) 0 (0) ✓

Note: To assign the private codes, please go to point 3a „Set the code“.

b) Multi User Mode

Enter Master Code	✓✓ 1 (9) Master Code ✓
Set mode	✓✓ 5 (5) 1 (9) ✓

Note: After changing the mode, all functions are reset to the default settings. This does not apply to the Master Code.

2 Set Code Length

Enter Master Code	✓✓ 1 (9) Master Code ✓
Select number of digits	✓✓ 0 (0) x ✓ 4 digits: x = 4 (6) 6 digits: x = 6 (4)

Note: After changing the number of digits, all codes stored in Private Mode are deleted.

3 Set Functions

a) Configuration in Private Mode

Set code	
Enter Master Code	✓✓ 1 (9) Master Code ✓
Set code	✓✓ 3 (7) xxxx (xx) ✓

Note: Up to 50 private codes can be stored. Depending on the set code length, these must be 4 or 6 digits long.

Delete the code

Enter Master Code	✓✓ 1 (9) Master Code ✓
Delete code	✓✓ 9 (1) xxxx (xx) ✓

Note: Enter the code you want to delete.

Automatic locking

Enter Master Code	✓✓ 1 (9) Master Code ✓
Activate	✓✓ 6 (4) 1 (9) ✓
Deactivate	✓✓ 6 (4) 0 (0) ✓

b) Configuration in Multi User Mode

Code confirmation

Enter Master Code	✓✓ 1 (9) Master Code ✓
Activate	✓✓ 2 (8) 1 (9) ✓
Deactivate	✓✓ 2 (8) 0 (0) ✓

c) Set General Functions

Set private Master Code

Enter current Master Code	✓✓ 1 (9) Master Code ✓
Enter new Master Code	✓✓ 7 (3) xxx xxx ✓

Note: The Master Code must be 6 digits long.

LED locking indication

Enter Master Code	✓✓ 1 (9) Master Code ✓
Activate	✓✓ 8 (2) 1 (9) ✓
Deactivate	✓✓ 8 (2) 0 (0) ✓

4 Reset to Default Settings

Enter general code	✓✓ 4 (6) general code ✓
--------------------	-------------------------

Note: If you have not requested your own general code when ordering, the Combipad can only be reset by a chargeable service call. We reserve the right to offer this service only in exceptional cases.

Operation

1 Operation in Private Mode

Lock	enter code
Unlock	enter code

2 Operation in Multi User Mode

Lock	enter code
Unlock	enter code

Note: If the code confirmation is set, the code must be entered twice when locking.

Master Code Entry

The Master Code can unlock the lock, authorize the configuration or terminate the block mode regardless of the set mode. Observe the following note when entering the Master Code:

Always start entering the Master Code by pressing the **hook key twice** and the **digit 1** (or 9 for the *Combipad Left* version).

Enter Master Code ✓✓ **1** (9) Master Code ✓

Note: In Multi User Mode, the code used for locking is deleted after entering the Master Code.

Battery Replacement

The batteries should be changed immediately as follows when the battery warning (p. 4) is active:

1. Loosen the screw of the battery compartment cover (Fig. p. 2) and remove the cover.
2. Remove empty batteries and insert new batteries according to the symbols (+ / -).
3. Close the battery compartment with the cover and fix it with the screw.

Disposal and Battery Note

EU Directive 2012/19/EU regulates the proper take-back, treatment and recycling of used electronic equipment.

Every consumer is required by law to dispose of batteries, accumulators or electrical and electronic equipment („waste equipment“) powered by batteries or accumulators separately from household waste, as they contain harmful substances and valuable resources. Disposal can be done at a collection or take-back point approved for this purpose, e.g. a local recycling center. Waste equipment, batteries or rechargeable batteries are accepted there free of charge and recycled in an environmentally friendly and resource-saving manner.

Waste equipment, used batteries or rechargeable batteries can also be returned to us. The return must be sufficiently stamped to the address below.

The following symbol on the waste electrical equipment, batteries or accumulators indicates that they must not be disposed of with household waste:



Caution when using batteries!

The battery may explode or release flammable gases if it is mishandled, destroyed, or the wrong type of battery is used. Do not recharge the battery, disassemble it, expose it to extremely high temperatures or throw it into a fire.

On batteries containing harmful substances, you will find indications in the form of abbreviations for the ingredients cadmium (Cd), mercury (Hg) and lead (Pb) in each case.

BURG Lüling GmbH & Co. KG

Volmarsteiner Str. 52
58089 Hagen (Germany)
+49(0)23 35 63 08-0

info@burg.de
www.burg.de